



Chipsmall Limited consists of a professional team with an average of over 10 year of expertise in the distribution of electronic components. Based in Hongkong, we have already established firm and mutual-benefit business relationships with customers from,Europe,America and south Asia,supplying obsolete and hard-to-find components to meet their specific needs.

With the principle of “Quality Parts,Customers Priority,Honest Operation,and Considerate Service”,our business mainly focus on the distribution of electronic components. Line cards we deal with include Microchip,ALPS,ROHM,Xilinx,Pulse,ON,Everlight and Freescale. Main products comprise IC,Modules,Potentiometer,IC Socket,Relay,Connector.Our parts cover such applications as commercial,industrial, and automotives areas.

We are looking forward to setting up business relationship with you and hope to provide you with the best service and solution. Let us make a better world for our industry!



## Contact us

Tel: +86-755-8981 8866 Fax: +86-755-8427 6832

Email & Skype: info@chipsmall.com Web: www.chipsmall.com

Address: A1208, Overseas Decoration Building, #122 Zhenhua RD., Futian, Shenzhen, China





# SP6651EB Evaluation Board Manual

- High Efficiency Synchronous Step-Down Converter with up to 98% efficiency
- 800mA Output Current, only 20uA Quiescent Current
- 2.7V-6.5V Input Voltage range, Output Adjustable down to 0.8V
- MSOP Package & Ceramic Capacitors for small, low profile Power Supply
- Ideal for PDAs, Digital Cameras, Wireless Modems, Cellular Telephones

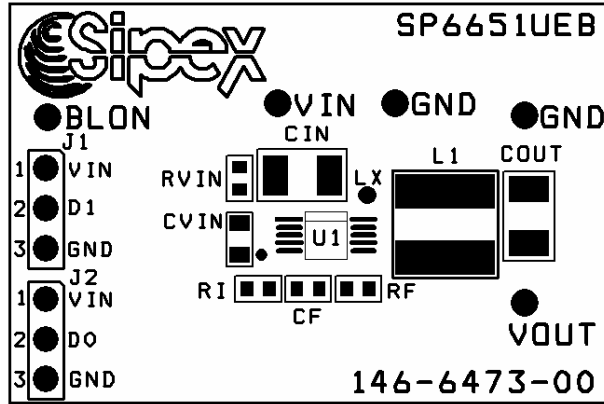

## DESCRIPTION

The **SP6651A Evaluation Board** is designed to help the user evaluate the performance of the SP6651A for use as a single Li-Ion battery Step-Down DC-DC Converter. The SP6651A operates from 2.7V to 6.5V input, with the highest efficiency in the range 3.0V to 4.2V where the Li-Ion battery has the most energy. The SP6651A evaluation board is a complete power supply circuit to provide ease of evaluation for the DC/DC Converter performance.

**FIGURE 1. SP6651A 3.3V OUTPUT EVALUATION BOARD SCHEMATIC**

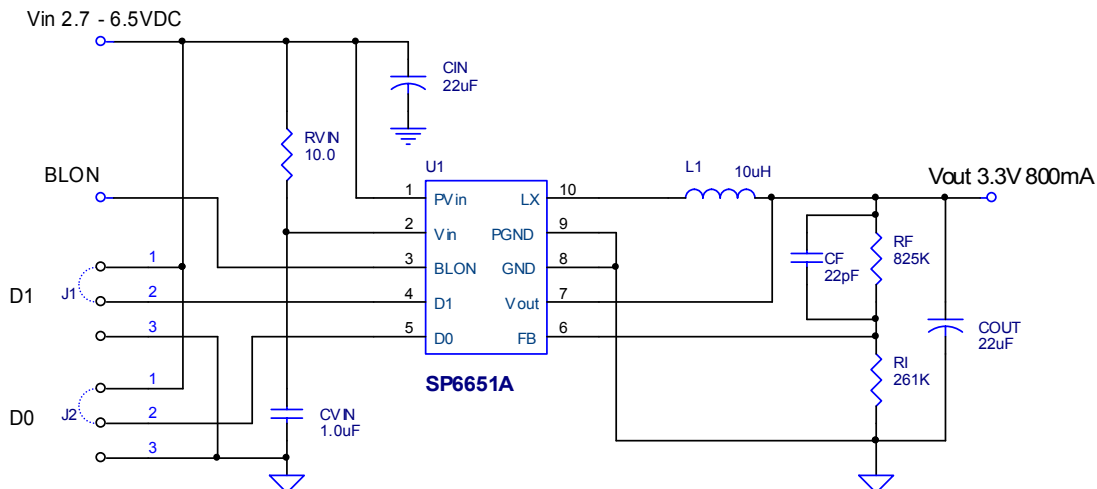

**FIGURE 2. SP6651A 1.5V OUTPUT EVALUATION BOARD SCHEMATIC**

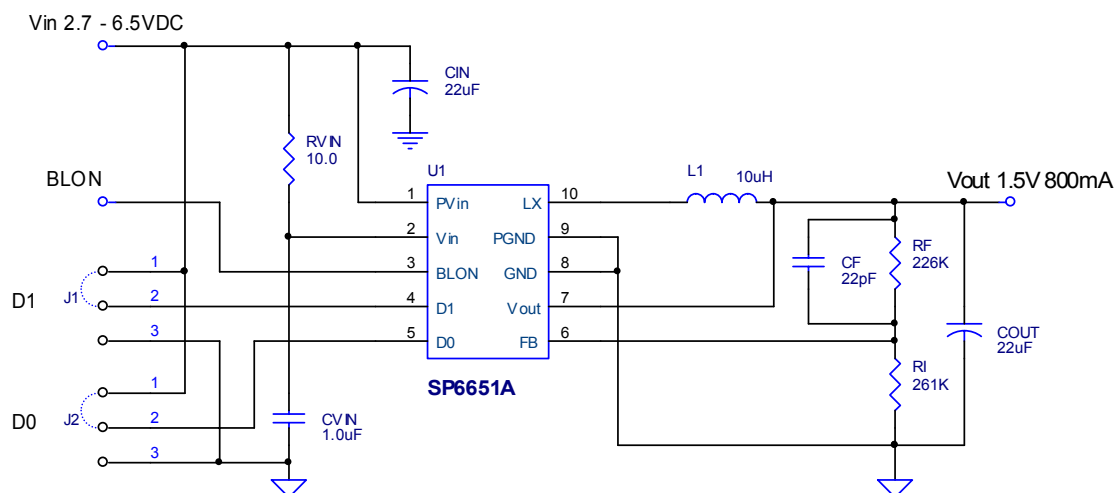

## USING THE EVALUATION BOARD

### 1) Powering up the SP6651A Circuit & Programming the UVLO threshold

The SP6651A Evaluation Board can be powered from a single Li-Ion battery or a +2.7 to +6.5V power supply. Connect with short leads directly to the “Vin” and “Gnd” posts. Note the SP6651A will remain in “shutdown” until D0 or D1 of the Jumpers J1 or J2 are applied to the Vin or position 1 to 2. See Table 1 for UVLO threshold programming and D1 and D0 pin definition.

**Table 1. Operating Mode Definition**

D1	D0	Definition
0	0	Shutdown. All internal circuitry is disabled and the power switches are opened.
0	1	Device enabled, falling UVLO threshold = 2.70V
1	0	Device enabled, falling UVLO threshold = 2.85V
1	1	Device enabled, falling UVLO threshold = 3.00V

### 2) VOUT PROGRAMMING

The SP6651A requires 2 feedback resistors to control the output voltage. Connect the appropriate resistors RF and RI (Table 2) from pin 6 SP6651A FB to Vout and to the GND.

For Vout different from that shown in the Table 2, use equation:

$$RF = \left( \frac{V_{out}}{0.8} - 1 \right) \cdot RI$$

**Table 2. SP6651EB BILL OF MATERIALS**

<b>Component</b>	<b>Vo = 3.3V</b>	<b>Vo = 1.5V</b>
L1	10uH, CDRH5D28-100, Sumida	10uH, CDRH5D28-100, Sumida
CIN	22uF, TDK C3225X5R0J226M	22uF, TDK C3225X5R0J226M
COUT	22uF, TDK C3225X5R0J226M	22uF, TDK C3225X5R0J226M
RVIN	10 Ohm 5%	10 Ohm 5%
CVIN	1uF ceramic X7R SM 0805	1uF ceramic X7R SM 0805
RI	261k 1%	261k 1%
RF	825k 1%	226k 1%
CF	22pF ceramic	22pF ceramic
U1	SP6651AEU	SP6651AEU

**Table 3. SP6651A PIN ASSIGNMENT**

<b>Pin Name</b>	<b>Pin Description</b>	<b>Pin NO.</b>
<b>PVin</b>	Input voltage power pin. Inductor charging current passes through this pin.	<b>1</b>
<b>Vin</b>	Internal supply voltage. Control circuitry powered from this pin.	<b>2</b>
<b>BLON</b>	Open drain battery low output – need to pullup to supply externally. Vin - Vout below threshold pulls this node to ground. Vin - Vout above threshold, this node is open.	<b>3</b>
<b>D1</b>	Digital mode control input. See Table 1 for definition.	<b>4</b>
<b>D0</b>	Digital mode control input. See Table 1 for definition.	<b>5</b>
<b>FB</b>	External feedback network input connection. Connect a resistor from FB to ground and FB to Vout to control the output voltage. This pin regulates to the internal reference voltage of 0.8V.	<b>6</b>
<b>Vout</b>	Output voltage sense pin. Used for internal timing and BLON circuitry.	<b>7</b>
<b>GND</b>	Internal ground pin. Control circuitry returns current to this pin.	<b>8</b>
<b>PGND</b>	Power ground pin. Synchronous rectifier current returns through this pin.	<b>9</b>
<b>LX</b>	Inductor switching node. Inductor tied between this pin and the output capacitor to create Vout.	<b>10</b>



EVALUATION BOARD LAYOUT

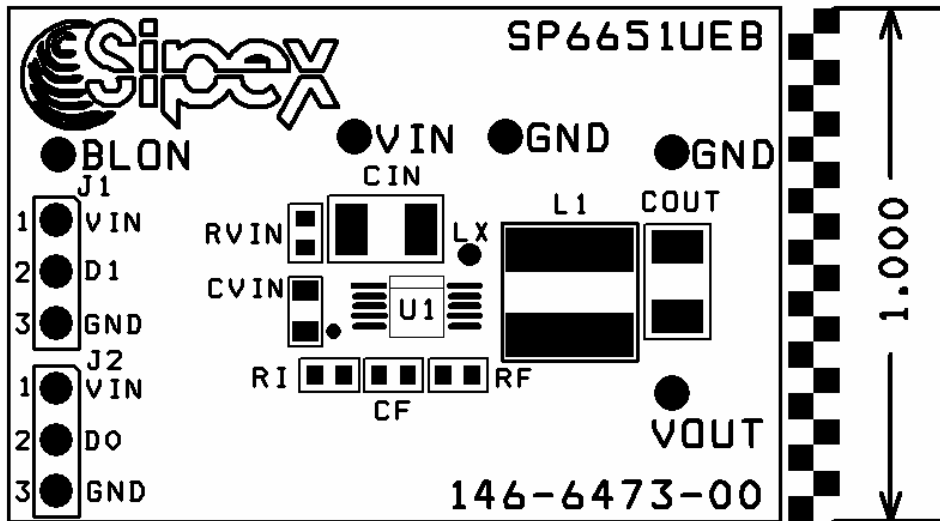

FIGURE 3: SP6651AEU COMPONENT PLACEMENT

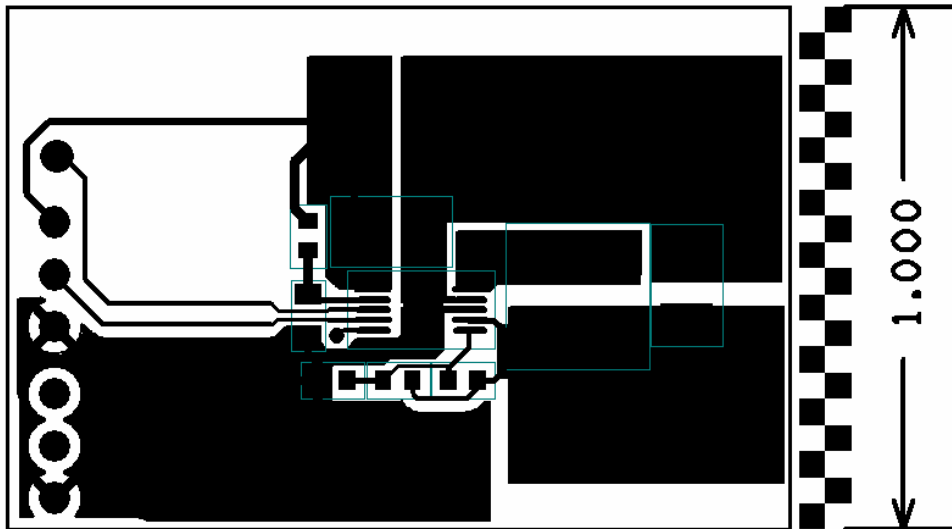

FIGURE 4: SP6651AEU PC LAYOUT TOP SIDE

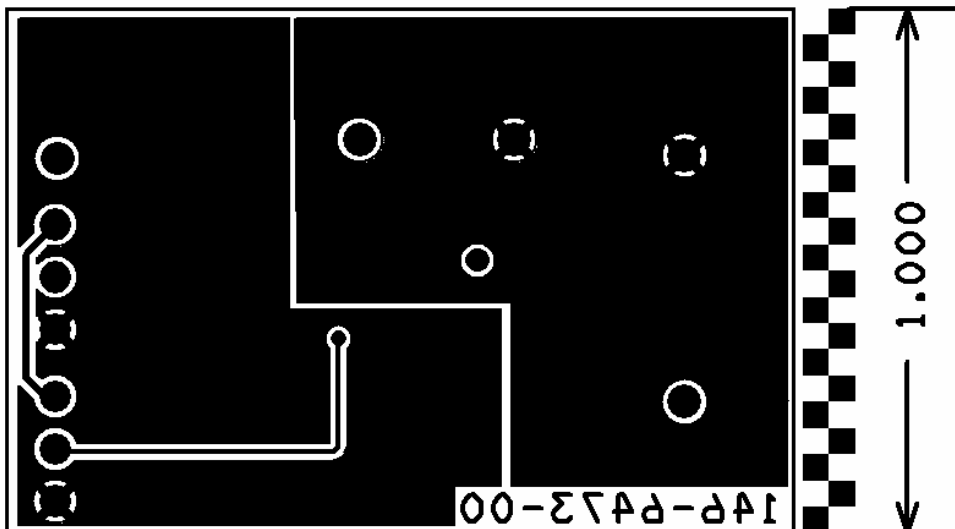

FIGURE 5: SP6651AEU PC LAYOUT BOTTOM SIDE

## ORDERING INFORMATION

Model	Temperature Range	Package Type
SP6651EB	.....-40°C to +85°C.....	SP6651 Evaluation Board