



Chipsmall Limited consists of a professional team with an average of over 10 year of expertise in the distribution of electronic components. Based in Hongkong, we have already established firm and mutual-benefit business relationships with customers from,Europe,America and south Asia,supplying obsolete and hard-to-find components to meet their specific needs.

With the principle of "Quality Parts,Customers Priority,Honest Operation,and Considerate Service",our business mainly focus on the distribution of electronic components. Line cards we deal with include Microchip,ALPS,ROHM,Xilinx,Pulse,ON,Everlight and Freescale. Main products comprise IC,Modules,Potentiometer,IC Socket,Relay,Connector.Our parts cover such applications as commercial,industrial, and automotives areas.

We are looking forward to setting up business relationship with you and hope to provide you with the best service and solution. Let us make a better world for our industry!



Contact us

Tel: +86-755-8981 8866 Fax: +86-755-8427 6832

Email & Skype: info@chipsmall.com Web: www.chipsmall.com

Address: A1208, Overseas Decoration Building, #122 Zhenhua RD., Futian, Shenzhen, China



GENERAL DESCRIPTION

The SP6669 is a synchronous current mode PWM step down (buck) converter capable of delivering up to 600mA of current and optimized for portable battery-operated applications.

Based on a current-mode 1.5MHz constant frequency PWM control scheme, the SP6669 reduces the overall component count and solution footprint. It provides low output voltage ripple and excellent line and load regulation. It also implements a 100% duty cycle LDO mode. Output voltage is adjustable to as low as 0.6V with a better than 3% accuracy while a low quiescent current supports the most stringent battery operating conditions.

Built-in over temperature and under voltage lock-out protections insure safe operations under abnormal operating conditions.

The SP6669 is offered in a RoHS compliant, "green"/halogen free 5-pin SOT23 package.

EVALUATION BOARD MANUAL



FEATURES

- **Guaranteed 600mA Output Current**
 - Input Voltage: 2.5V to 5.5V
- **1.5MHz PWM Current Mode Control**
 - 100% Duty Cycle LDO Mode Operations
 - Achieves 95% Efficiency
- **Adjustable Output Voltage Range**
 - As Low as 0.6V with $\pm 3\%$ Accuracy
- **Over Temperature & UVLO Protection**

EVALUATION BOARD SCHEMATICS

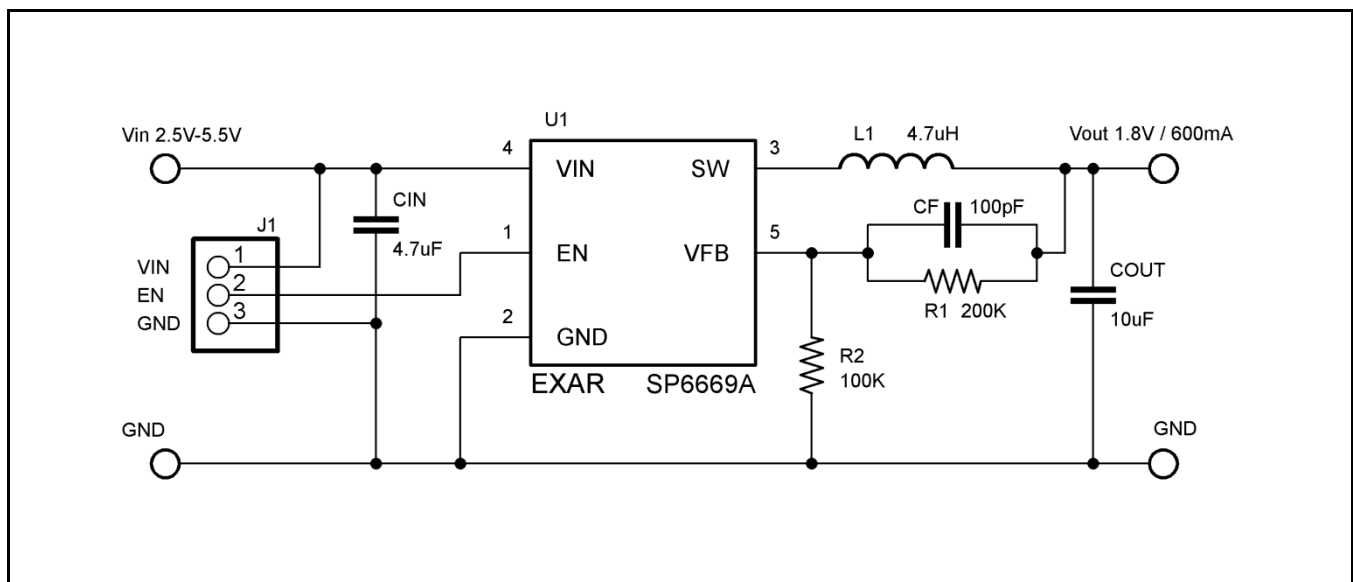

Fig. 1: SP6669 Evaluation Board Schematics

PIN ASSIGNMENT

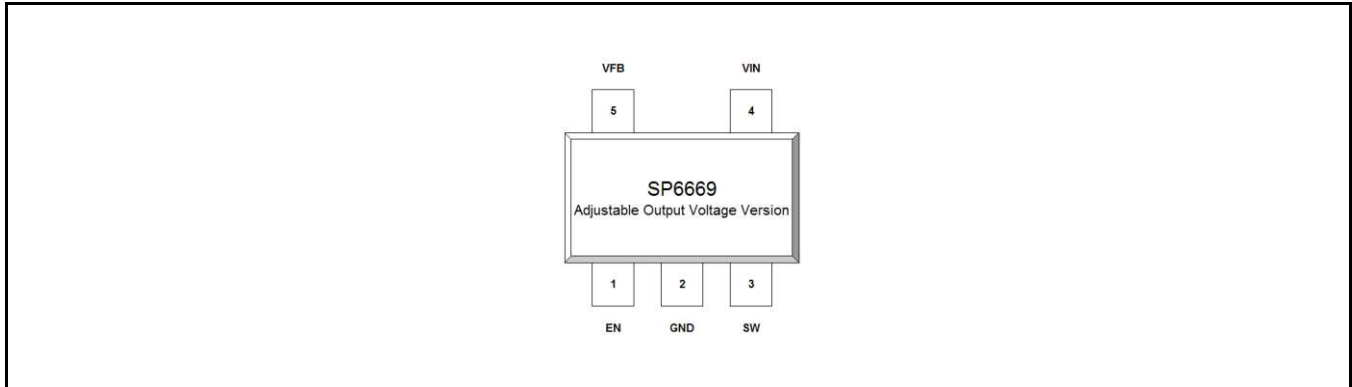

Fig. 2: SP6669 Pin Assignment

PIN DESCRIPTION

Name	Pin Number	Description
EN	1	Enable Pin. Do not leave the pin floating. $V_{EN} < 0.4V$: Shutdown mode $V_{EN} > 1.2V$: Device enabled
GND	2	Ground Signal Pin.
SW	3	Switching node.
VIN	4	Power Supply Pin. Must be decoupled to ground with a 4.7 μ F or greater ceramic capacitor.
VFB	5	Adjustable Version Feedback Input Pin. Connect VFB to the center point of the resistor divider.

ORDERING INFORMATION

Refer to SP6669's datasheet and/or www.exar.com for exact and up to date ordering information.

**USING THE EVALUATION BOARD****INITIAL SETUP**

Set the input supply to a voltage between 2.5V to 5.5V and connect it to VIN and GND connectors on the left side of the evaluation board. Connect the load to the VOUT and GND connectors on the right hand side of the board. Check to make sure that jumper J1 is set to VIN. The board will power-up and regulate to the desired output voltage VOUT set by the feedback resistors. The board will operate with a load current I_{OUT} of up to 600mA.

JUMPER J1 FUNCTION

Jumper J1 can be used to either short EN pin to VIN or to GND. The Board is supplied from EXAR with the jumper set to connect EN to VIN.

V_{OUT} PROGRAMMING

The SP6669 has a dynamically programmable output voltage using 2 feedback resistors to control the output voltage:

$$V_{OUT} = 0.6V \times \left(1 + \frac{R_1}{R_2}\right)$$

EVALUATION BOARD SCHEMATICS

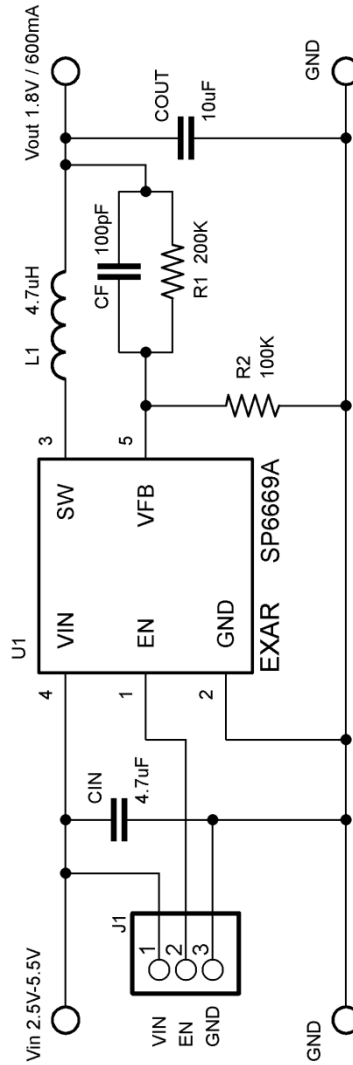

**BILL OF MATERIAL**

Ref.	Qty	Manufacturer	Part Number	Size	Component
Board	1	Exar Corp.	146-6595-00	1"x1.5"	SP6669 Eval board
U1	1	Exar Corp.	SP6669AEK-L	SOT23-5L	600mA Buck Reg.
CIN	1	Murata	GRM188R60J475KE19D	0603	Ceramic 4.7 μ F 6.3V X5R
COUT	1	Murata	GRM21BR60J106KE19	0805	Ceramic 10 μ F 6.3V X5R
CF	1	Murata	GRM1885C1H101JA01B	0603	Ceramic 100pF 50V COG
L1	1	Würth Elektronik	744025004	2.8mm x 2.8mm x 2.8mm	Inductor 4.7 μ H, 1.35A, 100m Ω
R1	1	Vishay	CRCW06032003F 0603	0603	200K Ω , 1/10W, 1%
R2	1	Vishay	CRCW06031003F	0603	100K Ω , 1/10W, 1%
J1	1	Würth Elektronik	61303611121	0.64mm SQ x 6mm	3 Pin Header, 2.54mm pitch
J1 (Jumper)	1	Würth Elektronik	609002115121	0.1"	Jumper short
TP	3	Mill-Max	0300-115-01-4727100	0.042" dia	Test Point Female Pin



REVISION HISTORY

Revision	Date	Description
1.0.0	09/16/2010	Initial release of document

FOR FURTHER ASSISTANCE

Email:

customersupport@exar.com

Exar Technical Documentation:

<http://www.exar.com/TechDoc/default.aspx?>

EXAR CORPORATION

HEADQUARTERS AND SALES OFFICES

48720 Kato Road

Fremont, CA 94538 – USA

Tel.: +1 (510) 668-7000

Fax: +1 (510) 668-7030

www.exar.com



NOTICE

EXAR Corporation reserves the right to make changes to the products contained in this publication in order to improve design, performance or reliability. EXAR Corporation assumes no responsibility for the use of any circuits described herein, conveys no license under any patent or other right, and makes no representation that the circuits are free of patent infringement. Charts and schedules contained here in are only for illustration purposes and may vary depending upon a user's specific application. While the information in this publication has been carefully checked; no responsibility, however, is assumed for inaccuracies.

EXAR Corporation does not recommend the use of any of its products in life support applications where the failure or malfunction of the product can reasonably be expected to cause failure of the life support system or to significantly affect its safety or effectiveness. Products are not authorized for use in such applications unless EXAR Corporation receives, in writing, assurances to its satisfaction that: (a) the risk of injury or damage has been minimized; (b) the user assumes all such risks; (c) potential liability of EXAR Corporation is adequately protected under the circumstances.

Reproduction, in part or whole, without the prior written consent of EXAR Corporation is prohibited.