



Chipsmall Limited consists of a professional team with an average of over 10 year of expertise in the distribution of electronic components. Based in Hongkong, we have already established firm and mutual-benefit business relationships with customers from,Europe,America and south Asia,supplying obsolete and hard-to-find components to meet their specific needs.

With the principle of "Quality Parts,Customers Priority,Honest Operation,and Considerate Service",our business mainly focus on the distribution of electronic components. Line cards we deal with include Microchip,ALPS,ROHM,Xilinx,Pulse,ON,Everlight and Freescale. Main products comprise IC,Modules,Potentiometer,IC Socket,Relay,Connector.Our parts cover such applications as commercial,industrial, and automotives areas.

We are looking forward to setting up business relationship with you and hope to provide you with the best service and solution. Let us make a better world for our industry!



Contact us

Tel: +86-755-8981 8866 Fax: +86-755-8427 6832

Email & Skype: info@chipsmall.com Web: www.chipsmall.com

Address: A1208, Overseas Decoration Building, #122 Zhenhua RD., Futian, Shenzhen, China





GENERAL DESCRIPTION

The SP6699 is an inductor-based DC/DC converter designed to drive up to six white LEDs in series for LCD modules and keypad backlighting functions.

Only one feedback resistor is needed to control the LED current and obtain the desired brightness. A 1.2MHz constant frequency PWM control scheme is used, enabling the usage of small external components. A typical application needs a 1mm tall inductor and a 0.22 μ F output capacitor. Additionally, the boost circuit Schottky diode is integrated, further reducing the overall foot print.

A logic controlled enable pin allows this device to be placed in a low current consumption mode of a few microamps. Furthermore, the SP6699 is equipped with an over voltage output protection circuit which clamps the output voltage to 30 volts when any LED fails or in other abnormal conditions.

The SP6699 is offered in a small lead free, RoHS compliant 6-pin SOT23 package.

APPLICATIONS

- LCD Modules
- Keypad Backlighting
- Digital Cameras
- GPS Receivers
- Portable Media Players

FEATURES

- **High Output Voltage: Up to 30V**
 - Drives 2 to 6 LEDs @ 20mA
 - High Efficiency up to 84%
- **Integrated Schottky Diode**
- **Fast 1.2MHz Switching Frequency**
- **200mV Feedback Voltage**
- **PWM Dimming Capability up to 2KHz**
- **Over Output Voltage Protection**
- **Internal Soft Start Circuit**
- **Small SOT23-6 Package**

TYPICAL APPLICATION DIAGRAM

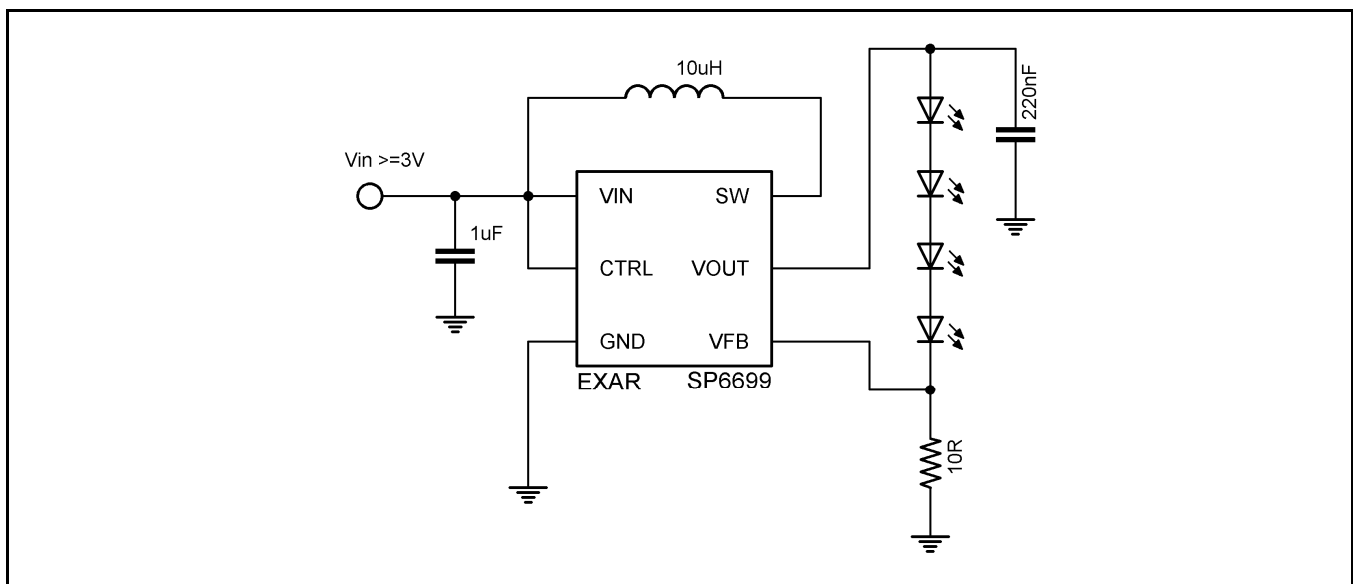

Fig. 1: SP6699 Application Diagram

ABSOLUTE MAXIMUM RATINGS

These are stress ratings only and functional operation of the device at these ratings or any other above those indicated in the operation sections of the specifications below is not implied. Exposure to absolute maximum rating conditions for extended periods of time may affect reliability.

Input Voltage V_{IN} 20V
 SW Voltage 38V
 FB Voltage 20V
 CTRL Voltage 20V
 Operating Junction Temperature 150°C
 Storage Temp. Range T_{STG} -65°C to 150°C
 Lead Temperature (sold. 10s) T_{LEAD} 260°C
 ESD Ratings – Human Body Model 2000V
 ESD Ratings – Machine Model 250V
 Moisture Sensitivity Level (MSL) 3

OPERATING RATINGS

Input Voltage Range V_{IN} 2.7V to 16V
 Operating Temperature Range -40°C to 85°C
 CTRL Voltage V_{CTRL} 16V
 Thermal Resistance (Junction to Ambient) $R_{\theta JA}$ 265°C/W
 Thermal Resistance (Junction to case) $R_{\theta JC}$ 60°C/W

ELECTRICAL SPECIFICATIONS

Specifications with standard type are for an Operating Junction Temperature of $T_A = 25^\circ\text{C}$ only; limits applying over the full Operating Junction Temperature range are denoted by a “•”. Minimum and Maximum limits are guaranteed through test, design, or statistical correlation. Typical values represent the most likely parametric norm at $T_A = 25^\circ\text{C}$, and are provided for reference purposes only. Unless otherwise indicated, $V_{IN} = 3\text{V}$, $V_{CTRL} = 3\text{V}$, $T_A = 25^\circ\text{C}$.

Parameter	Min.	Typ.	Max.	Units	Conditions
Operating Voltage	2.5		16	V	
Feedback Voltage V_{FB}	188	200	212	mV	• $I_{OUT} = 20\text{mA}$, 4 LEDs
FB Pin Bias Current I_{FB}		35	100	nA	
Supply Current I_{CC}	1.5	2.5	3.2	mA	$V_{FB} = V_{IN}$, not switching
Supply Current I_Q	2.0	4.0	6.0	μA	$V_{CTRL} = 0\text{V}$
Switching Frequency f	0.9	1.2	1.5	MHz	
Maximum Duty Cycle D_{MAX}	90	93		%	
Switch Current Limit I_{LIMIT}		550		mA	$T_A = 25^\circ\text{C}$, $D = 40\%$
		550		mA	$T_A = 25^\circ\text{C}$, $D = 80\%$
Switch V_{CE} Saturation Voltage V_{CESAT}		360		mV	$I_{SW} = 250\text{mA}$
Switch Leakage Current		0.01	5	μA	$V_{SW} = 5\text{V}$
CTRL Pin Voltage V_{CTRL} - High	1.8			V	
CTRL Pin Voltage V_{CTRL} - Low			0.5	V	
CTRL Bias Current I_{CTRL}		100		μA	
Schottky Forward Drop V_{DROP}		0.7		V	$I_D = 150\text{mA}$
OVP Trip Point		30		V	
Schottky Leakage Current		0.1	4	μA	$V_R = 23\text{V}$
			150	μA	$V_R = 27\text{V}$
Soft Start Time t		300		μs	

BLOCK DIAGRAM

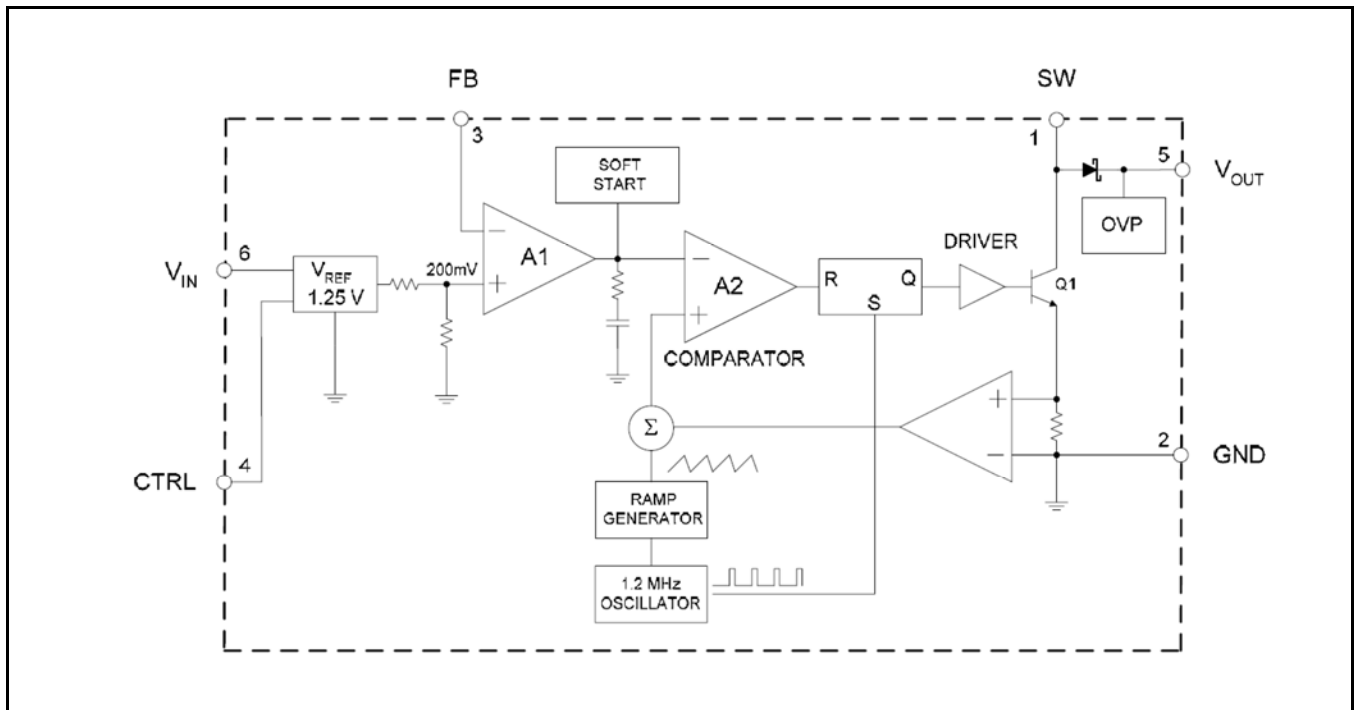

Fig. 2: SP6699 Block Diagram

PIN ASSIGNMENT

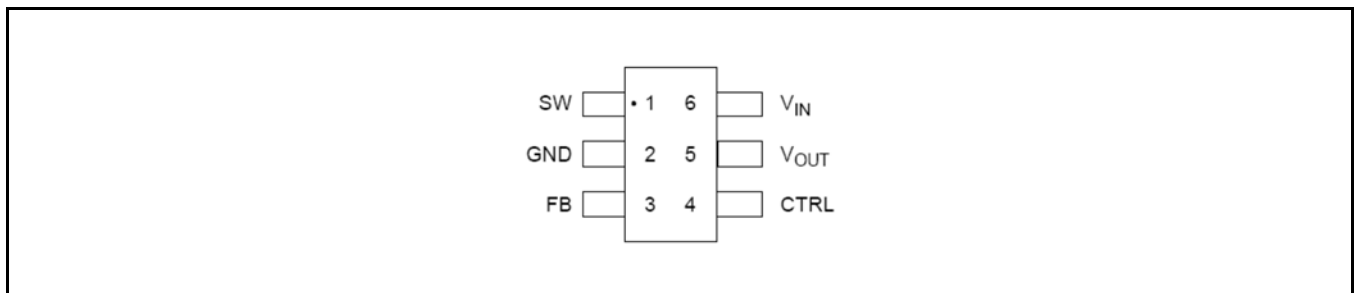

Fig. 3: SP6699 Pin Assignment

PIN DESCRIPTION

Name	Pin Number	Description
SW	1	Switch pin. Connect external inductor
GND	2	Ground signal pin
FB	3	Voltage Feedback. Reference voltage is 200mV
CTRL	4	Shutdown and dimming pin. Connect to 1.8V or higher to enable device; Connect to 0.5V or less to disable device; Connect to a PWM signal of 2kHz or less to achieve LEDs brightness dimming
VOUT	5	Output pin. Connected to the cathode of the internal Schottky diode.
VIN	6	Input supply pin. Must be locally bypassed.

ORDERING INFORMATION

Part Number	Temperature Range	Marking	Package	Packing Quantity	Note 1
SP6699EK-L/TR	-40°C ≤ T _A ≤ +85°C	PBWW	SOT-23-6	3K/Tape & Reel	Lead Free
SP6699EB	SP6699 Evaluation Board				

“WW” = Work Week

Note that the SP6699 series is packaged in Tape and Reel with a reverse part orientation as per the following diagram

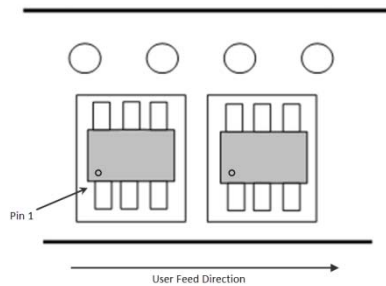

TYPICAL PERFORMANCE CHARACTERISTICS

All data taken at $V_{IN} = 3.6V$, $EN = V_{IN}$, $R_{SET} = 24k\Omega$, $T_A = 25^\circ C$, unless otherwise specified - Schematic and BOM from Application Information section of this datasheet.

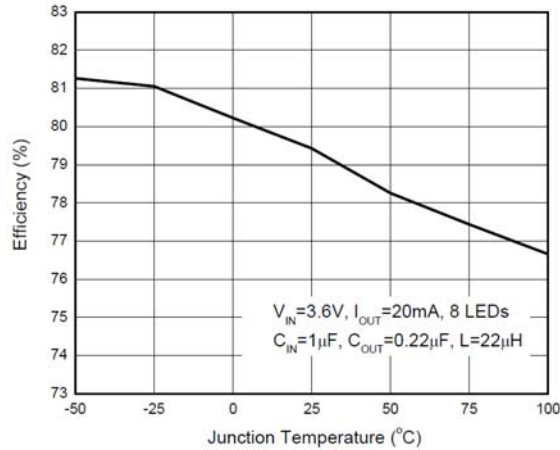

Fig. 4: Efficiency vs. Junction Temperature

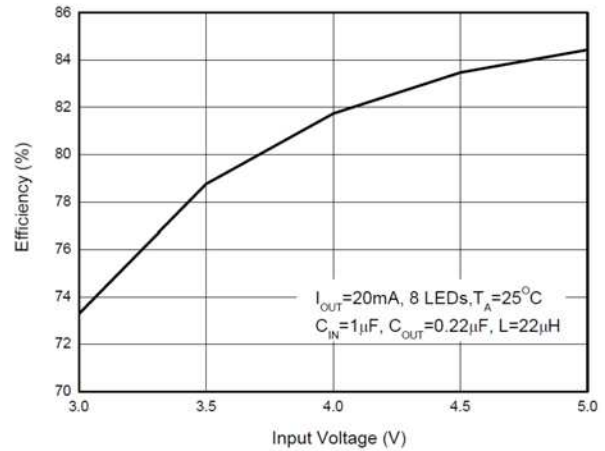

Fig. 5: Efficiency vs. Input Voltage

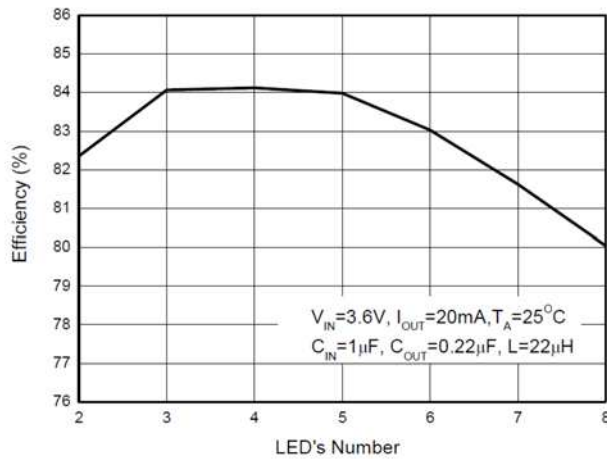

Fig. 6: Efficiency vs. Number of LEDs

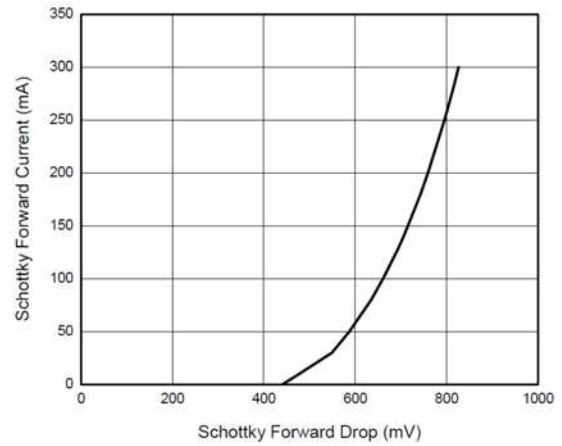

Fig. 7: Schottky Forward Current vs Schottky Forward Drop

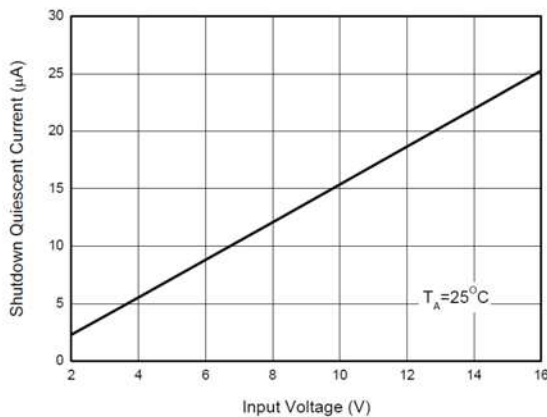

Fig. 8: Shutdown Quiescent Current vs Input Voltage

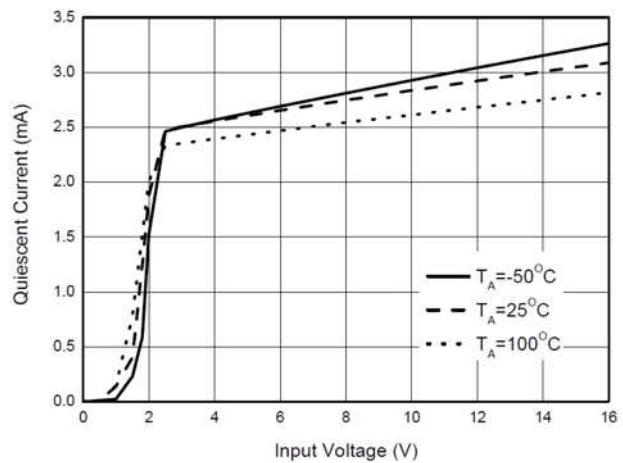

Fig. 9: Supply Current vs Input Voltage

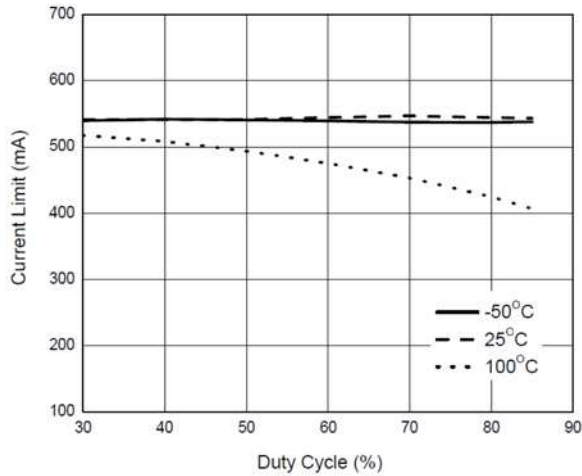

Fig. 10: Current Limit vs. Duty Cycle

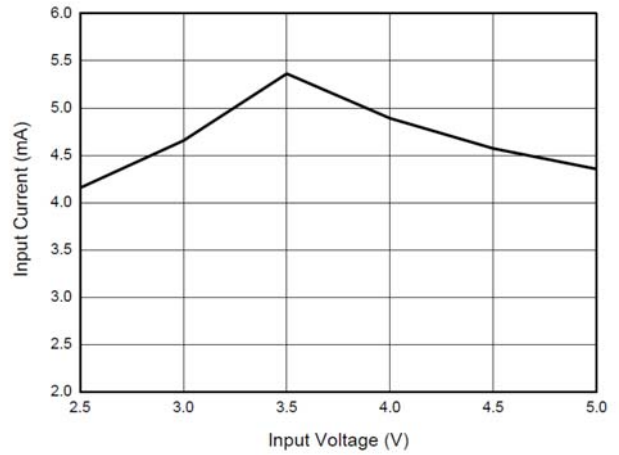

Fig. 11: Input Current in Output Open Circuit vs Input Voltage

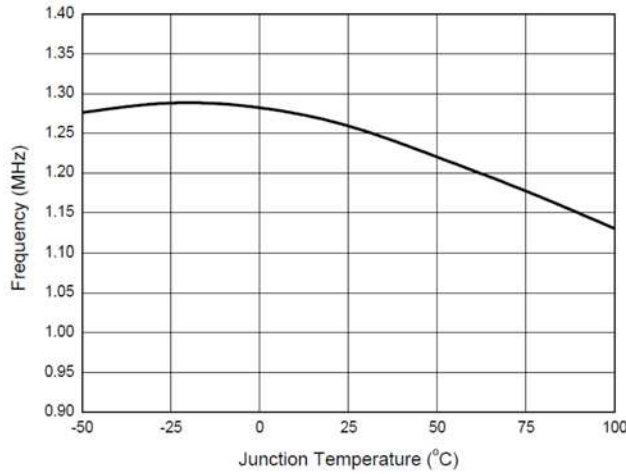

Fig. 12: Switching Frequency vs Junction Temperature

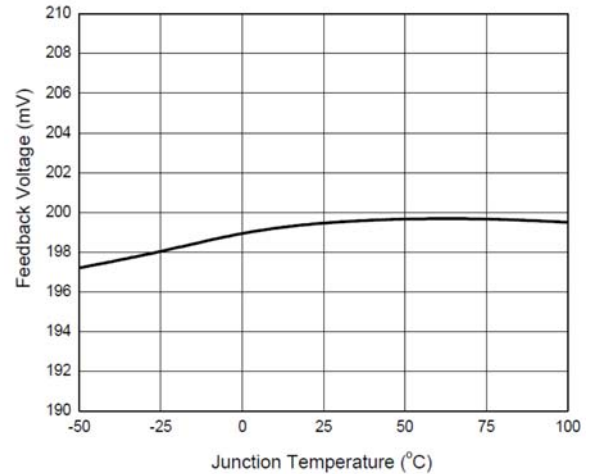

Fig. 13: Feedback Voltage vs Junction Temperature

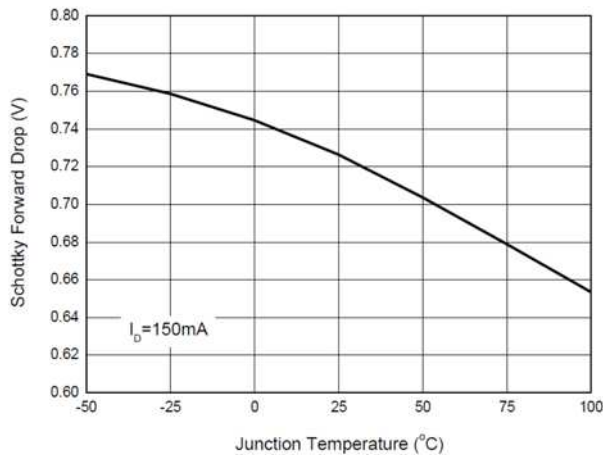

Fig. 14: Schottky Forward Drop vs Junction Temperature

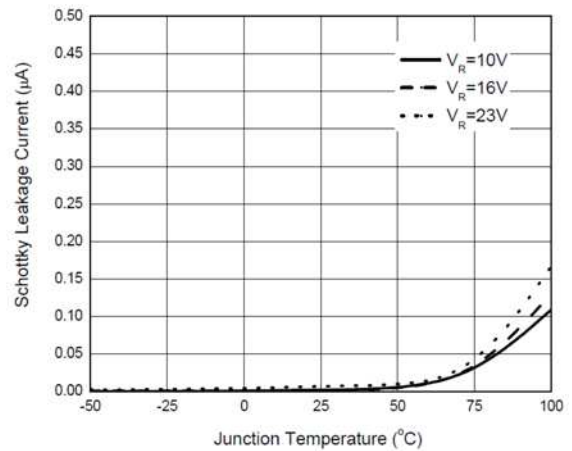

Fig. 15: Schottky Leakage Current vs Junction Temperature

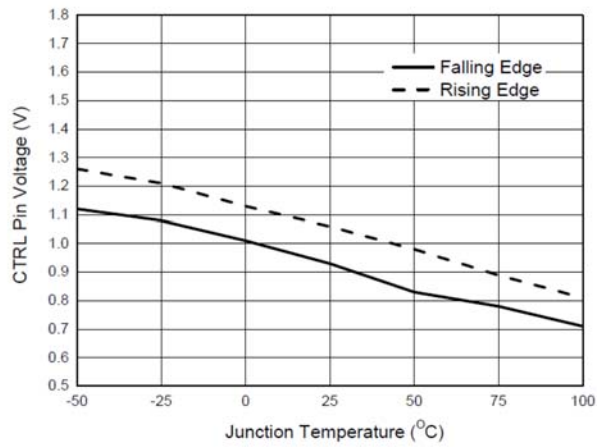

Fig. 16: CTRL Pin Voltage vs. Junction Temperature

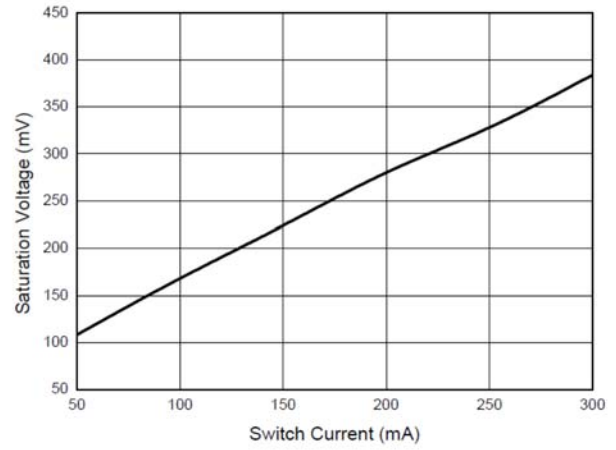

Fig. 17: Switch Saturation Current vs Switch Current

THEORY OF OPERATION

DETAILED DESCRIPTION

The SP6699 is a boost DC-DC converter which uses a constant frequency, current mode control scheme to provide excellent line and load regulation. Operation can be best understood by referring to the Figure 1 on the first page or Figure 18 below. At the start of each oscillator cycle, the SR latch is set and the switch Q1 turns on. The switch current will increase linearly. The voltage on sense resistor is proportional to the switch current. The output of the current sense amplifier is added to a stabilizing ramp and the result is fed into the non-inversion input of the PWM comparator A2. When this voltage exceeds the output voltage level of the error amplifier A1, the SR latch is reset and the switch is turned off. It is clear that the voltage level at non-inversion input of A2 sets the peak current level to keep the output in regulation. This voltage level is the output signal of error amplifier A1, and is the amplified signal of the voltage difference between feedback voltage and reference voltage of 200mV. So, a constant output current can be provided by this operation mode.

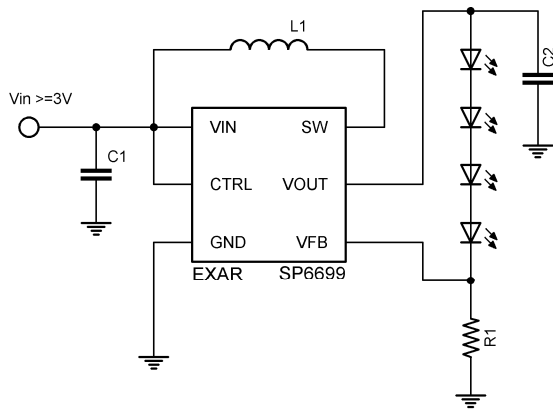

Fig. 18: R1 Selection Typical Application Circuit

LED CURRENT CONTROL

Refer to Figure 18; the LED current is controlled by the feedback resistor R1. LEDs' current accuracy is determined by the regulator's feedback threshold accuracy and is independent of the LED's forward voltage variation. So the precise resistors are preferred. The resistance of R1 is in inverse proportion to the LED current since the feedback reference is fixed at 200mV. The relation for R1 and LED current can be expressed as below:

$$R1 = 200\text{mV} / I_{LED}$$

OVER VOLTAGE PROTECTION

The SP6699 has an internal open-circuit protection circuit. When the LEDs are disconnected from the circuit or fail open, the output voltage is clamped at 30V. The SP6699 will switch at a low frequency, and minimize input current.

SOFT START

The SP6699 has an internal soft start circuit to limit the inrush current during startup. The startup delay is controlled by internal soft start capacitor. Please refer to Figure 19.

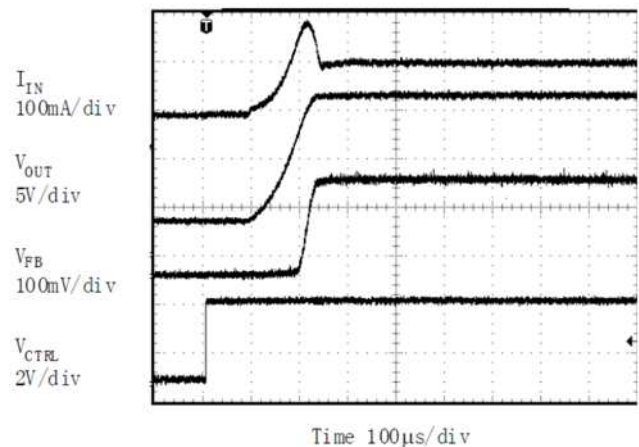

Fig. 19: Soft Start Waveform
 $V_{IN} = 3.6\text{V}$, 5 LEDs, $I_{LED} = 20\text{mA}$

DIMMING CONTROL

Two typical types of dimming control circuit are present. First, is providing a PWM input into the CTRL Pin. This is typically preferred in that this will result in constant color from the LED while changing the brightness. Second, changing the feedback voltage to get appropriate duty and luminous intensity is also possible.

Adding a control signal to CTRL pin

First, adding a PWM Signal to the CTRL pin directly. The SP6699 is turned on or off by the PWM signal when it is applied on the CTRL pin. The typical frequency of this PWM signal is 200Hz to 2KHz. Please refer to figure 20.

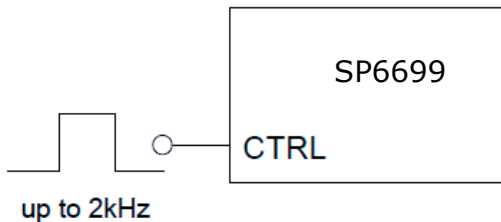

Fig. 20: Dimming Control using a PWM Signal on CTRL Pin

Changing the effective feedback voltage

There are three methods to change the effective feedback voltage.

First, adding a constant DC voltage through a resistor divider to FB pin can control the dimming. Changing the DC voltage or resistor between the FB Pin and the DC voltage can get appropriate luminous intensity. Comparing with all kinds of PWM signal control, this method features a stable output voltage and LEDs current. Please refer to figure 21.

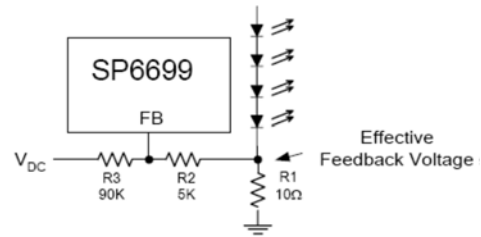

Fig. 21: Dimming Control using a DC Voltage

Second, using a filtered PWM signal can do it. The filtered PWM signal can be considered as a varying and adjustable DC voltage.

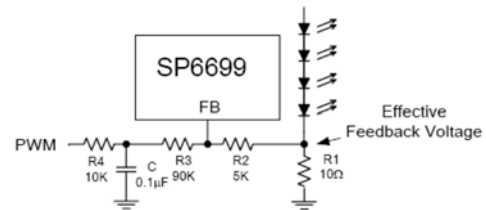

Fig. 22: Dimming Control using a Filtered PWM Voltage

Third, is using a logic signal to change the feedback voltage. For example, the FB pin is connected to the GND through a MOSFET and a resistor. And this MOSFET is controlled by a logic signal. The luminous intensity of LEDs will be changed when the MOSFET turns on or off.

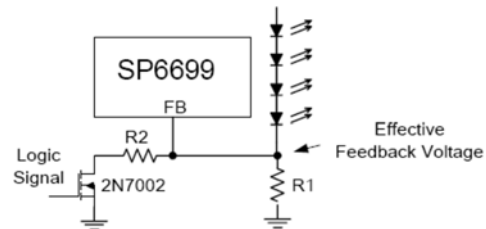
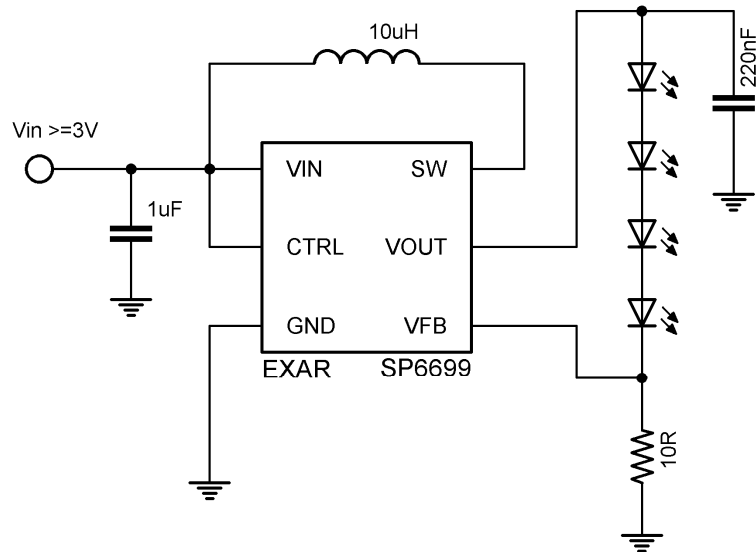

Fig. 23: Dimming Control using Logic Signal

TYPICAL APPLICATION CIRCUITS

4 White LEDs Driver



C: X5R or X7R Dielectric
 L: Sumida CDRH5D28R-100NC or equivalent
 For use over the full operating temperature range

5 (or 6) White LEDs Driver

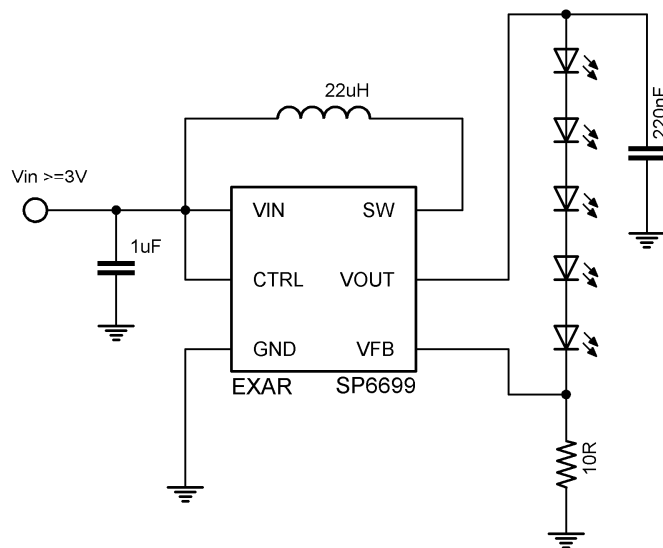

C: X5R or X7R Dielectric
 L: Sumida CDRH5D28R-220NC or equivalent
 For use over the full operating temperature range

PACKAGE SPECIFICATION

6-PIN SOT23

Unit: mm (inch)

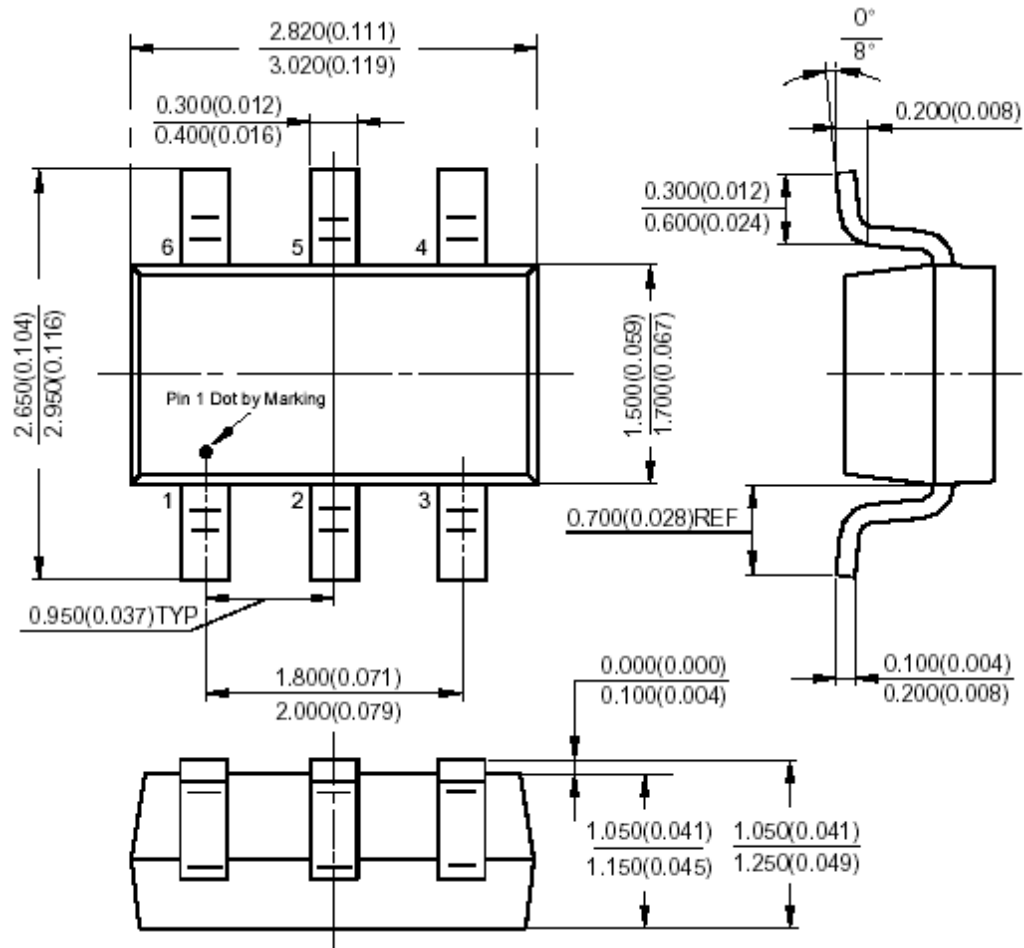

REVISION HISTORY

Revision	Date	Description
E	01/21/08	Initial Data Sheet
2.0.0	04/27/09	Reformat of Datasheet Corrections of typographical errors
2.1.0	10/01/2011	Inclusion of Tape and Reel part orientation and MSL level information
3.0.0	04/06/2014	Eliminated analog dimming function on CTRL pin and improved logic level low compatibility for PWM inputs. Increase maximum switch voltage allowing more LEDs in series. Current limit now constant across duty cycle. Shutdown and non-switching Iq slightly changed. Nominal operating frequency increased to 1.2MHz. Reference voltage over temp improved. Recommended maximum PWM dimming frequency increased from 1kHz to 2kHz. ECN 1422-02

FOR FURTHER ASSISTANCE

Email:

customersupport@exar.com

powertechsupport@exar.com

Exar Technical Documentation:

<http://www.exar.com/TechDoc/default.aspx?>



EXAR CORPORATION

HEADQUARTERS AND SALES OFFICES

48720 Kato Road

Fremont, CA 94538 – USA

Tel.: +1 (510) 668-7000

Fax: +1 (510) 668-7030

www.exar.com

NOTICE

EXAR Corporation reserves the right to make changes to the products contained in this publication in order to improve design, performance or reliability. EXAR Corporation assumes no responsibility for the use of any circuits described herein, conveys no license under any patent or other right, and makes no representation that the circuits are free of patent infringement. Charts and schedules contained here in are only for illustration purposes and may vary depending upon a user’s specific application. While the information in this publication has been carefully checked; no responsibility, however, is assumed for inaccuracies.

EXAR Corporation does not recommend the use of any of its products in life support applications where the failure or malfunction of the product can reasonably be expected to cause failure of the life support system or to significantly affect its safety or effectiveness. Products are not authorized for use in such applications unless EXAR Corporation receives, in writing, assurances to its satisfaction that: (a) the risk of injury or damage has been minimized; (b) the user assumes all such risks; (c) potential liability of EXAR Corporation is adequately protected under the circumstances.

Reproduction, in part or whole, without the prior written consent of EXAR Corporation is prohibited.