



Chipsmall Limited consists of a professional team with an average of over 10 year of expertise in the distribution of electronic components. Based in Hongkong, we have already established firm and mutual-benefit business relationships with customers from,Europe,America and south Asia,supplying obsolete and hard-to-find components to meet their specific needs.

With the principle of “Quality Parts,Customers Priority,Honest Operation,and Considerate Service”,our business mainly focus on the distribution of electronic components. Line cards we deal with include Microchip,ALPS,ROHM,Xilinx,Pulse,ON,Everlight and Freescale. Main products comprise IC,Modules,Potentiometer,IC Socket,Relay,Connector.Our parts cover such applications as commercial,industrial, and automotives areas.

We are looking forward to setting up business relationship with you and hope to provide you with the best service and solution. Let us make a better world for our industry!



Contact us

Tel: +86-755-8981 8866 Fax: +86-755-8427 6832

Email & Skype: info@chipsmall.com Web: www.chipsmall.com

Address: A1208, Overseas Decoration Building, #122 Zhenhua RD., Futian, Shenzhen, China



Evaluation Board Manual

- LED Driver for common cathode parallel connected LEDs
- Ultra Low Dropout Voltage of 150mV
- No EMI, no switching noise
- Integrated current matching
- PWM and Analog brightness control
- Enable/Shutdown control
- Shutdown current < 1 μ A
- Small footprint SOT23-6 Package

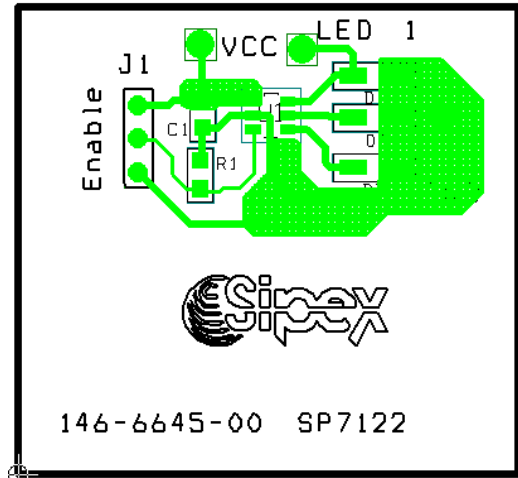

DESCRIPTION

The SP712X driver's family provides a simple solution for a matched current source for any color common cathode LEDs. The common cathode connection allows the user to increase the led power dissipation by having the cathodes heat sinked to the ground plane of the circuit board. The SP7120 may drive two LEDs or one LED at twice the current with two channels connected in parallel. The factory preset current values of 15mA (version A), 20mA (version B), or 25mA (version C) per channel. The SP7122 has three channels with factory preset current values of 15, 20, or 25mA and may drive three LEDs or one LED at three-times the current with all channels connected in parallel. At shutdown mode (EN pin is LOW) the supply current drops to .04 μ A typical. The SP712x drivers are available in a small footprint 6-pin SOT23-6 package.

BOARD SCHEMATIC

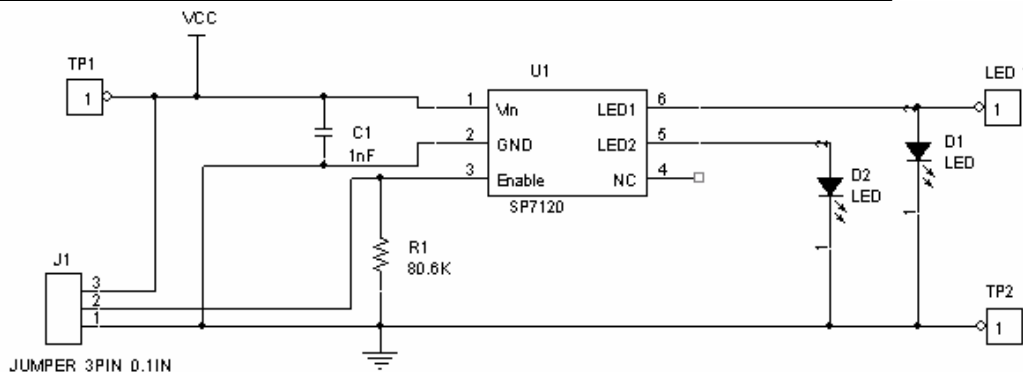

SP7120 Eval Board Schematic

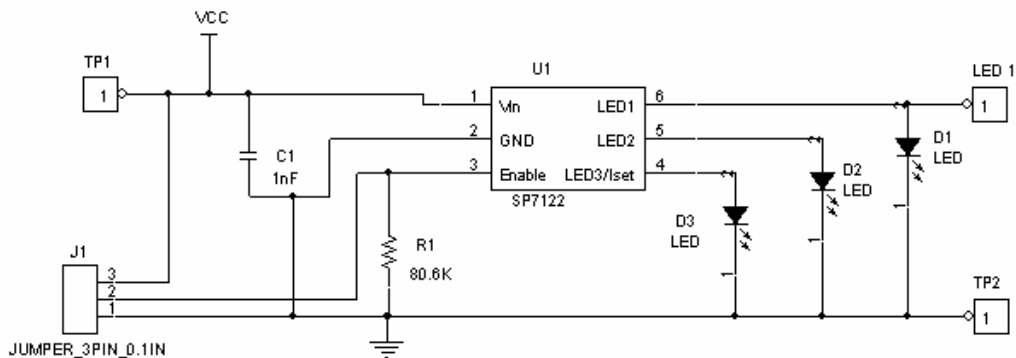

SP7122 Eval Board Schematic

USING THE EVALUATION BOARD

1) Powering Up the SP7120 or the SP7122 Circuit

The Evaluation Board can be powered from inputs ranging from 2.7 to 5.5Vin. All that is required is to populate the LED location with desired LED and connect the source voltage to Vin and GND. There is a jumper located on the PCB. The jumper needs to be set between center pin and Vin to activate the part. If the jumper is left unpopulated the driver will be off due to the pull down resistor on the enable pin.

For typical test results please refer to the data sheet.

EVALUATION BOARD LAYOUT

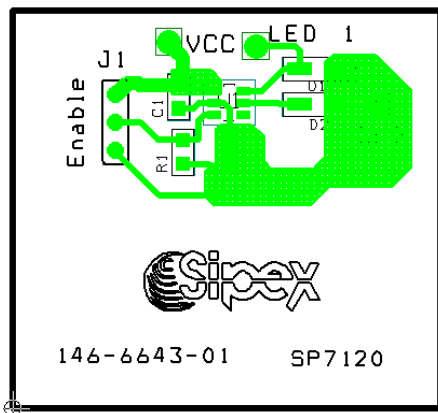

TOP Side SP7120

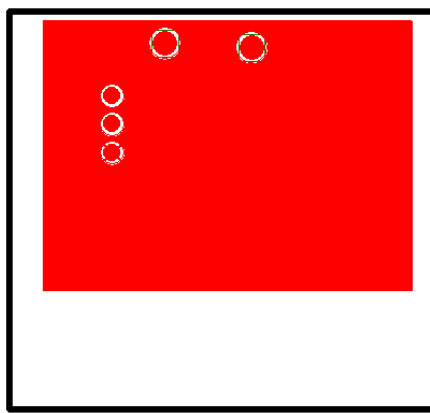

TOP Side SP7122

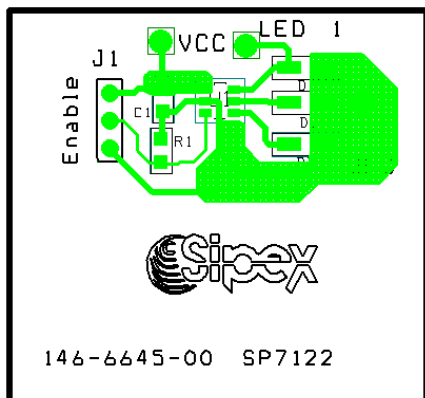

TOP Side SP7122

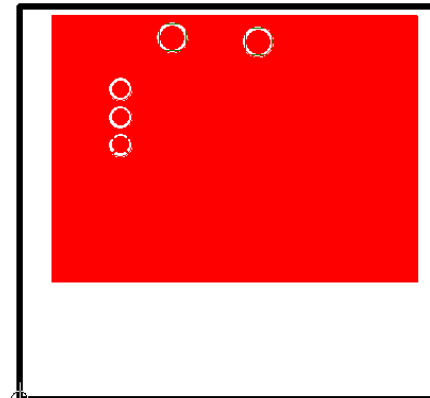

TOP Side SP7122

SP7120

QTY	Ref Desigantor	Manufacturer	Part Number	Description
1	U1	Sipex	SP7120***	
2	C1	Murata	GRM188R71H102KA01	1nF Capacitor
1	R1	Vishay	CRCW060380K6FKEA	80.6K Resistor
1	J1	Würth	61303611121	3 Pin 2.54 mm Header
1		Würth	60900213421	2.54mm Jumper
3		Millmax(DigiKey)	0300-11501-4727100	Test point pin
1		Sipex	146-6643-01	PCB

*****EACH PCB WILL HAVE A STICKER ON IT IDENTIFYING THE WHICH VERSION IC IS ON THE DEMO BOARD**

SP7122

QTY	Ref Desigantor	Manufacturer	Part Number	Description
1	U1	Sipex	SP7122***	
2	C1	Murata	GRM188R71H102KA01	1nF Capacitor
1	R1	Vishay	CRCW060380K6FKEA	80.6K Resistor
1	J1	Würth	61303611121	3 Pin 2.54 mm Header
1		Würth	60900213421	2.54mm Jumper
3		Millmax(DigiKey)	0300-11501-4727100	Test point pin
1		Sipex	146-6645-00	PCB

*****EACH PCB WILL HAVE A STICKER ON IT IDENTIFYING THE WHICH VERSION IC IS ON THE DEMO BOARD**

Part Number	Description
SP7120AEB	SP7120A 2 channel (15mA) Eval Board
SP7120BEB	SP7120B 2 channel(20mA) Eval Board
SP7120CEB	SP7120C 2 channel(25mA) Eval Board
SP7122AEB	SP7122A 3 channel(15mA) Eval Board
SP7122BEB	SP7122B 3 channel (20mA) Eval Board
SP7122CEB	SP7122C 3 channel (25mA) Eval Board

For further assistance:

Email: Sipexsupport@sipex.com
WWW Support page: <http://www.sipex.com/content.aspx?p=support>
Sipex Application Notes: <http://www.sipex.com/applicationNotes.aspx>



Sipex Corporation
Headquarters and
Sales Office
233 South Hillview Drive
Milpitas, CA95035
tel: (408) 934-7500
fax: (408) 935-7600

Sipex Corporation reserves the right to make changes to any products described herein. Sipex does not assume any liability arising out of the application or use of any product or circuit described herein; neither does it convey any license under its patent rights nor the rights of others.