



Chipsmall Limited consists of a professional team with an average of over 10 year of expertise in the distribution of electronic components. Based in Hongkong, we have already established firm and mutual-benefit business relationships with customers from,Europe,America and south Asia,supplying obsolete and hard-to-find components to meet their specific needs.

With the principle of “Quality Parts,Customers Priority,Honest Operation,and Considerate Service”,our business mainly focus on the distribution of electronic components. Line cards we deal with include Microchip,ALPS,ROHM,Xilinx,Pulse,ON,Everlight and Freescale. Main products comprise IC,Modules,Potentiometer,IC Socket,Relay,Connector.Our parts cover such applications as commercial,industrial, and automotives areas.

We are looking forward to setting up business relationship with you and hope to provide you with the best service and solution. Let us make a better world for our industry!



Contact us

Tel: +86-755-8981 8866 Fax: +86-755-8427 6832

Email & Skype: info@chipsmall.com Web: www.chipsmall.com

Address: A1208, Overseas Decoration Building, #122 Zhenhua RD., Futian, Shenzhen, China





SP7648 Evaluation Board Manual

- Easy Evaluation for the SP7648 Single or Dual Cell Alkaline to 2V to 5V Output
- Provides 700mA output at 3.6V output for Li-Ion Input
- High Efficiency: 94%
- μ SOIC Package & SMT components for small, low profile Power Supply

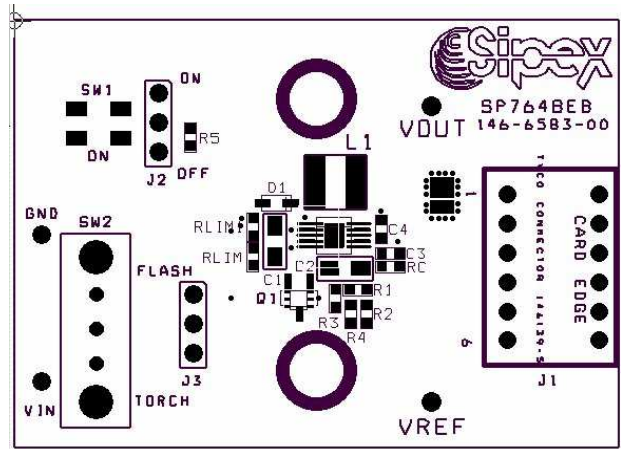

DESCRIPTION

The **SP7648 Evaluation Board** is designed to help the user evaluate the performance of the SP7648 for use as a single/dual cell Alkaline or single cell Li-Ion to drive 1W LED. The output of the SP7648 is preset to +5V or can be adjusted from +2V to +5V by manipulating two external resistors. The evaluation board is a completely assembled and tested surface mount board which provides easy probe access points to all SP7648 Inputs and Outputs so that the user can quickly connect and measure electrical characteristics and waveforms.

SP7648 EVALUATION BOARD SCHEMATIC

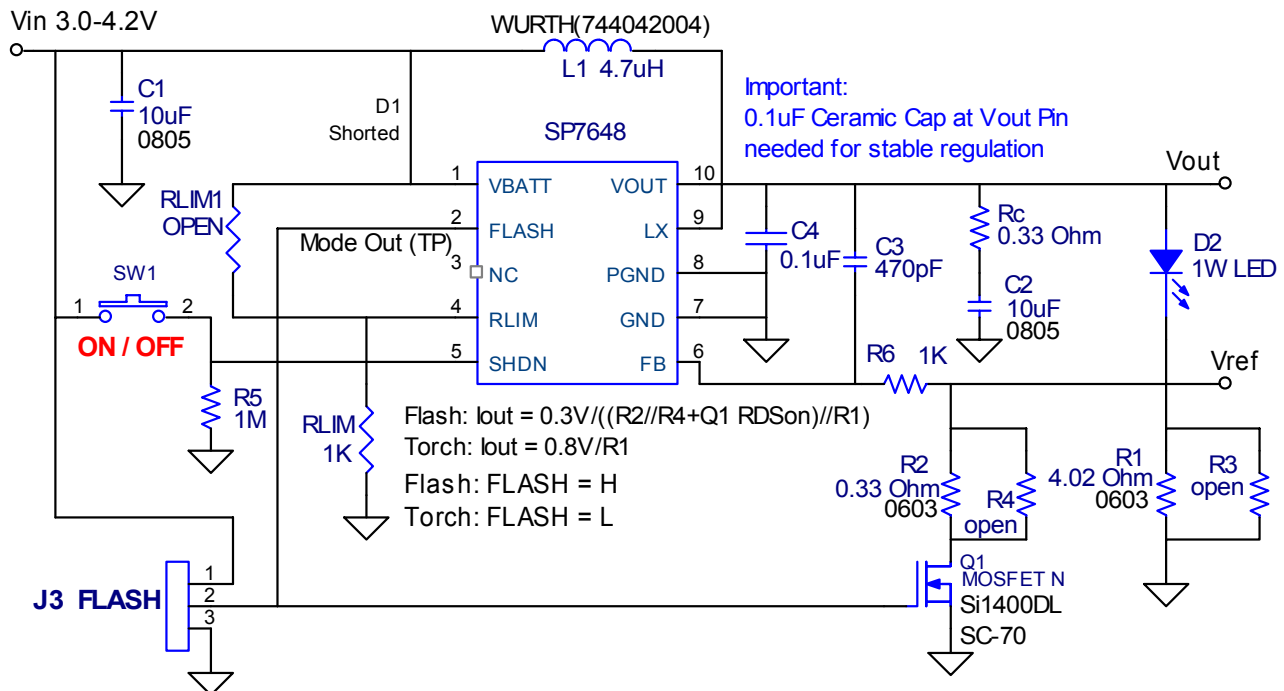

USING THE EVALUATION BOARD

1) Powering Up the SP7648 Circuit

The SP7648 Evaluation Board can be powered from inputs from +2.7V to +4.2V from a Li-Ion battery. Connect with short leads directly to the “Vbatt” and “Gnd” posts. Monitor the Output, Vref Voltage and connect the LED between the “Vout” post and the “Vref” post.

2) Using the SW1 switch and the J3 Jumper: Enabling the SP7648 Output and using the Shutdown Mode

Pressing the ON/OFF button (SW1) will put the SHDN pin to VIN, which enables the SP7648. Otherwise the 1M R5 pull-down puts 0V to the SHDN pin and puts the SP7648 in the low quiescent Shutdown Mode. The SP7648 output will be in FLASH mode if the J3 Jumper is in the top or pin 1 to 2 position. If J3 is in the pin 2 to 3 position, the SP7648 will be in the Torch mode.

3) Using the Rlim Function

The peak inductor current, I_{PEAK} , is programmed externally by the RLIM resistor connected between the RLIM pin and GND. The peak inductor current is defined by:

$$I_{PEAK} = 1600/R_{LIM}$$

The SP7648 has a range for RLIM of 1.0K to 9.09K ohms. Using the IPEAK equation above gives an IPEAK range of

$$I_{PEAK} \text{ range} = 176\text{mA to } 1600\text{mA.}$$

The saturation current specified for the inductor needs to be greater than the peak current to avoid saturating the inductor, which would result in a loss in efficiency and could damage the inductor. The SP7648 evaluation board uses an Rlim value of 1.0K for an Ipeak = 1600mA to allow the circuit to deliver 700mA for 3.6V input. Other values could be selected using the above relationships.

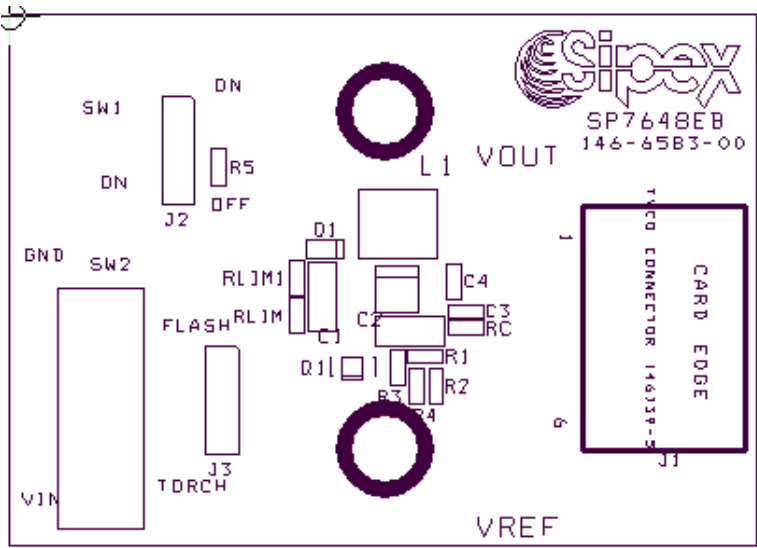

FIGURE 1: SP7648UEB COMPONENT PLACEMENT

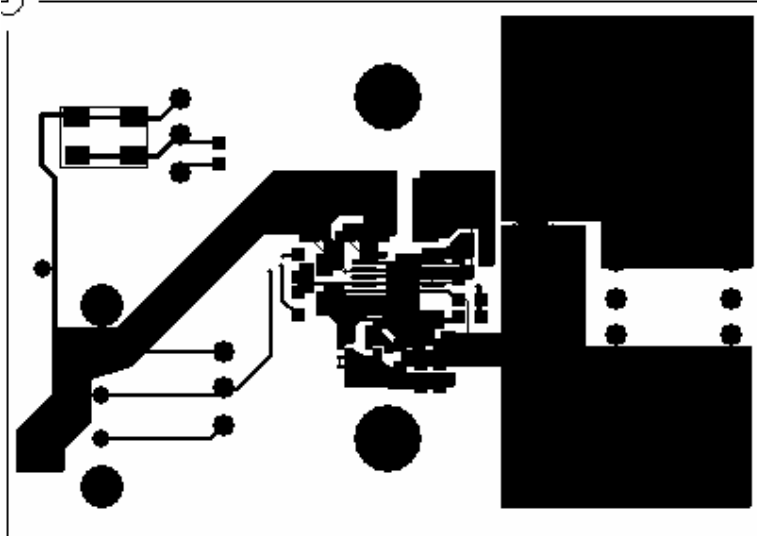

FIGURE 2: SP7648UEB PC LAYOUT TOP SIDE

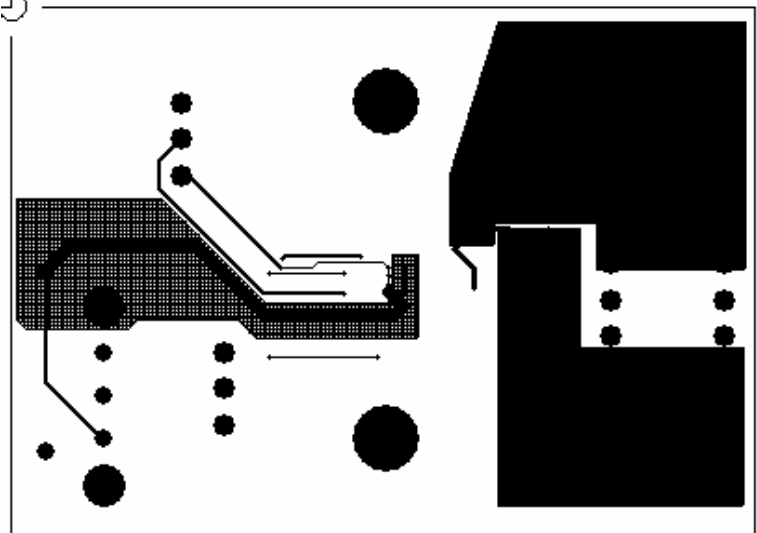

FIGURE 3: SP7648UEB PC LAYOUT BOTTOM SIDE

TABLE1: SP7648EB LIST OF MATERIALS

SP7648 Evaluation Board List of Materials						
Ref. Des.	Qty.	Manufacturer	Part Number	Layout	Component	Vendor
				Size		
	1	Sipex Corp.	146-6583-00		SP7648UEB Eval PC Board	Sipex 978-667-7800
U1	1	Sipex Corp.	SP7648EU	uSO-8	10-pin uSOIC Step-Up DC/DC Conv	www.sipex.com
C1,2	2	TDK Corp	C2012X5R0J106M	0805	Ceramic 6.3V 10uF SM	www.tdk.com
C3	1	TDK Corp	C1608COG1H471J	0603	Ceramic 50V 470pF SM 0.02ohm ESR	www.tdk.com
C4	1	TDK Corp	C1608X7R1E104M	0603	Ceramic 25V 0.1uF SM 0.02ohm ESR	www.tdk.com
L1	1	Würth Elektronik	744042004	4.8x4.8x1.8mm	4.7uH, 1.7A, 0.07ohm, SM Inductor	www.we-online.com
R1	1	Vishay	CRCW06034R02F	0603	4.02 ohm 1/10W 1% 0603 SM	www.vishay.com
R2,Rc	1	Vishay	CRCW0603R33F	0603	0.33 ohm 1/10W 1% 0603 SM	www.vishay.com
R3			OPEN			www.vishay.com
R4			OPEN			
R5	1	Vishay	CRCW0603105J	0603	1M ohm 1/10W 5% 0603 SM	www.vishay.com
R6	1	Vishay	CRCW0603102J	0603	1K ohm 1/10W 5% 0603 SM	www.vishay.com
RLIM1			OPEN			
RLIM	1	Vishay	CRCW06031001F	0603	1K ohm 1/10W 1% 0603 SM	www.vishay.com
D1			SHORTED			
Q1	1	Fairchild	FDN337N	SOT23	30V 2.2A 0.082 Ohm N-Chan MOSFET	www.fairchildsemi.com
		Vishay	Si1400DL	SC-70	MOSFET 20V 1.7A 0.15Ohm@4.5V	www.vishay.com
SW1	1	Bournes	7914J-1-E		On / Off Switch	www.bournes.com
SW2			N/A			
J1			N/A			
J2			N/A			www.digikey.com
J3	3	Sullins	PTC36SAAN	.23 x .12	3-Pin Header	www.digikey.com
	1	Sullins	STC02SYAN	.2x.1	Shunt	www.digikey.com
TP	4	Mill-Max	0300-115-01-4727100	.042 Dia	Test Point Female Pin	www.digikey.com

ORDERING INFORMATION

Model	Temperature Range	Package Type
SP7648UEB.....	-40°C to +85°C.....	SP7648 Evaluation Board
SP7648EU.....	-40°C to +85°C.....	10-pin μSOIC