



Chipsmall Limited consists of a professional team with an average of over 10 year of expertise in the distribution of electronic components. Based in Hongkong, we have already established firm and mutual-benefit business relationships with customers from,Europe,America and south Asia,supplying obsolete and hard-to-find components to meet their specific needs.

With the principle of “Quality Parts,Customers Priority,Honest Operation,and Considerate Service”,our business mainly focus on the distribution of electronic components. Line cards we deal with include Microchip,ALPS,ROHM,Xilinx,Pulse,ON,Everlight and Freescale. Main products comprise IC,Modules,Potentiometer,IC Socket,Relay,Connector.Our parts cover such applications as commercial,industrial, and automotives areas.

We are looking forward to setting up business relationship with you and hope to provide you with the best service and solution. Let us make a better world for our industry!



Contact us

Tel: +86-755-8981 8866 Fax: +86-755-8427 6832

Email & Skype: info@chipsmall.com Web: www.chipsmall.com

Address: A1208, Overseas Decoration Building, #122 Zhenhua RD., Futian, Shenzhen, China



REVISIONS				
REV.	ECO. NO	DESCRIPTION	DATE	BY
A	2146	INITIAL RELEASE	07/16/2010	LH
B	2456	CORRECTED OPEN TOP VIEW TO MATCH PART, UPDATED DWG FORMAT	9/22/2011	JH

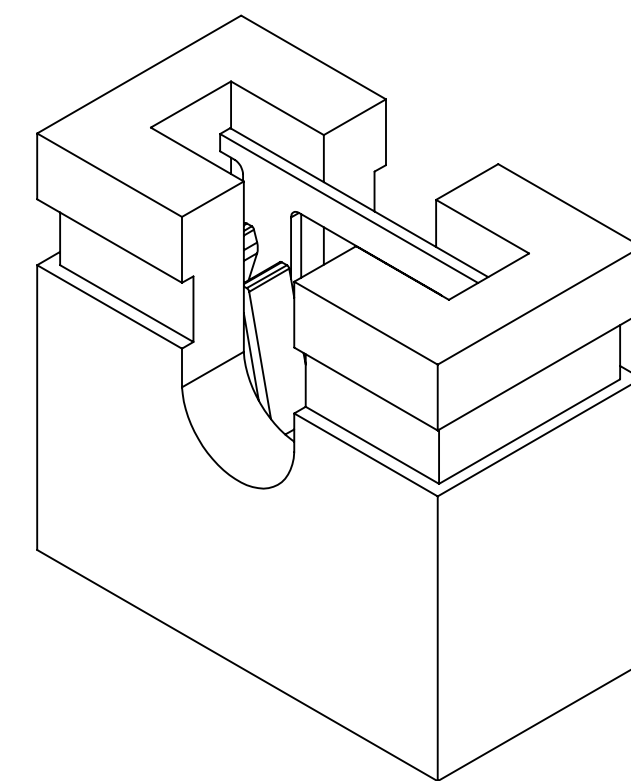
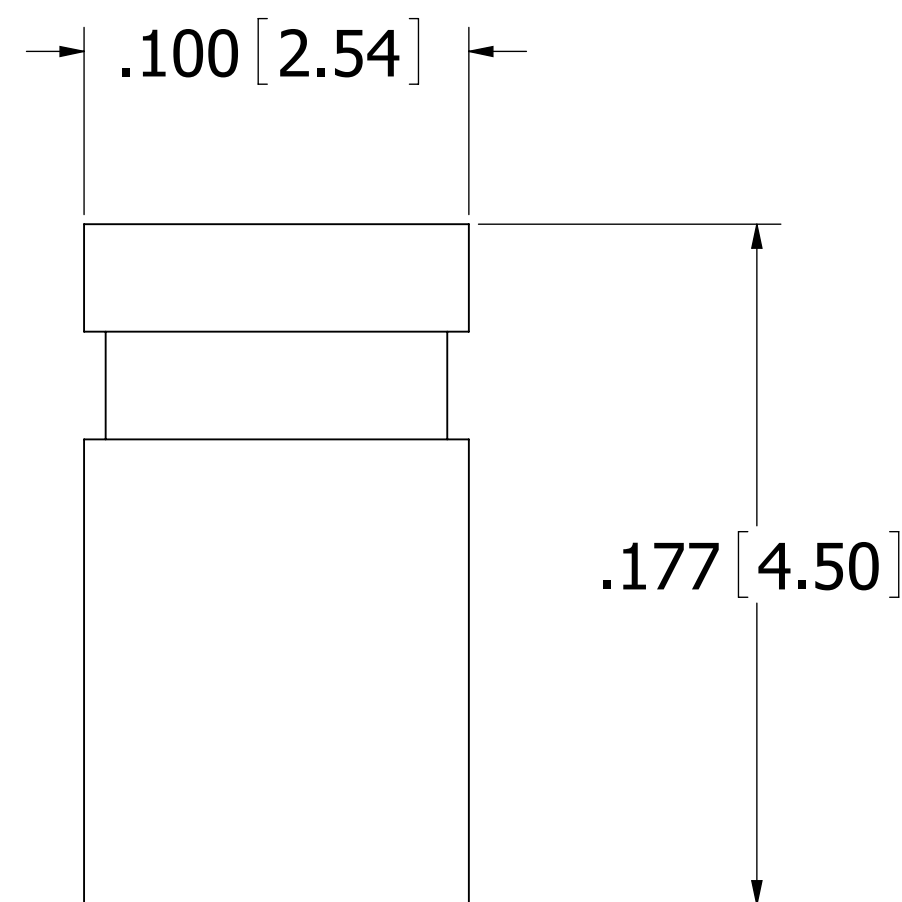
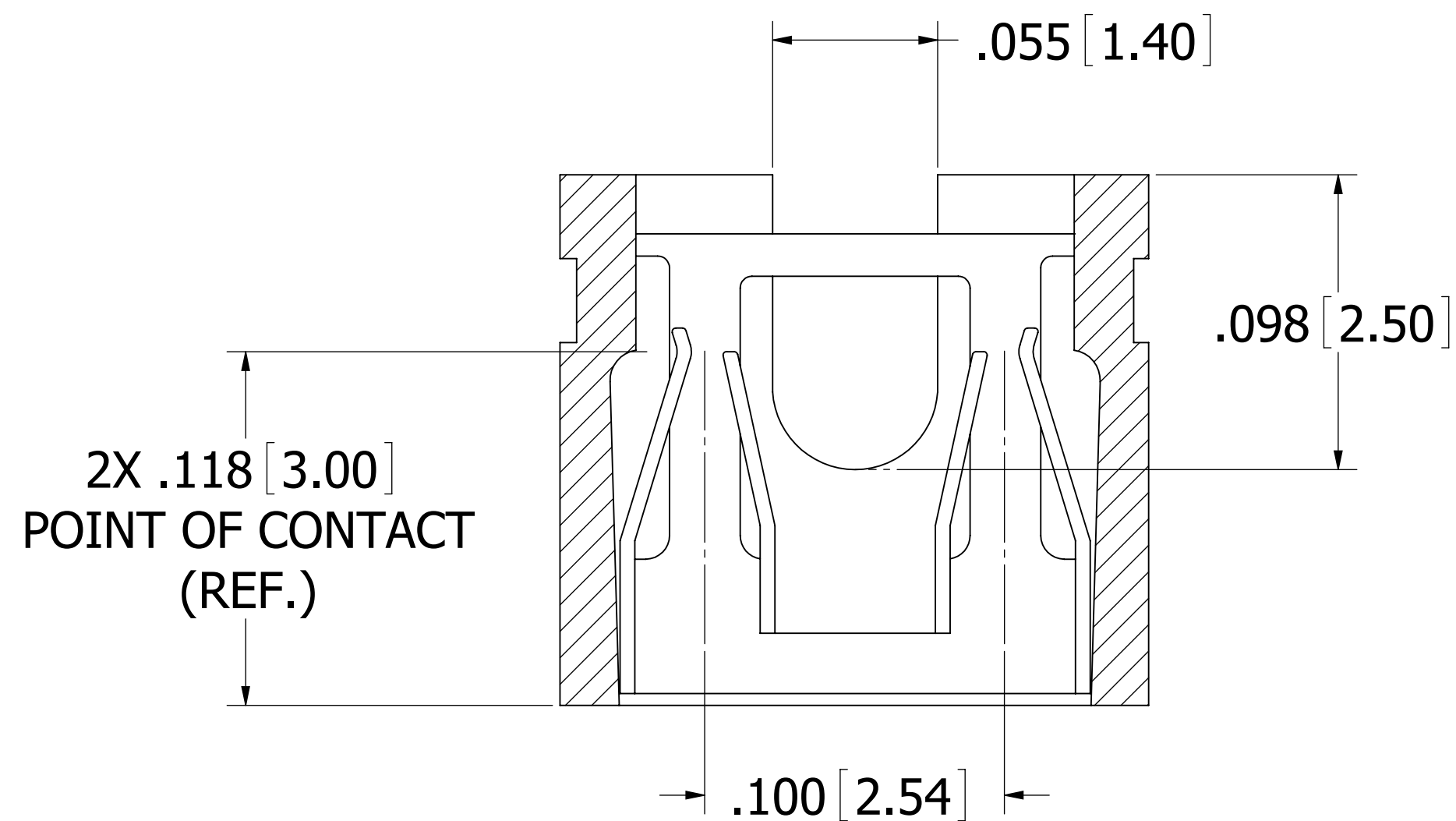

SECTION A - A

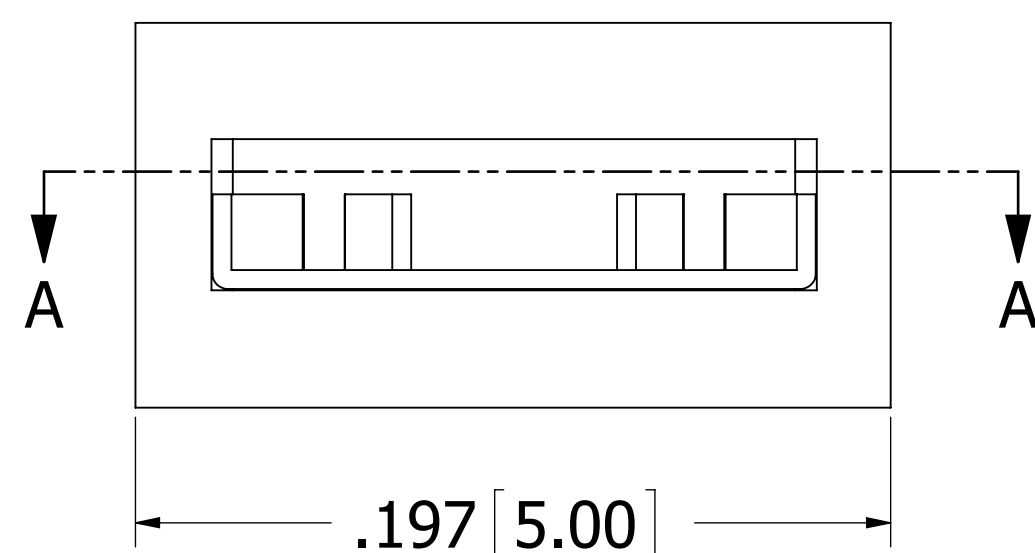

- NOTES:**
1. INSULATOR MATERIAL: PBT.
 2. CONTACT MATERIAL: PHOSPHOR BRONZE.
 3. PLATING: GOLD FLASH OVERALL.
 4. UL FLAMMABILITY RATING: 94V-0.
 5. DIELECTRIC WITHSTANDING VOLTAGE: 650V AC.
 6. CURRENT RATING: 3 AMPS PER CONTACT.
 7. CONTACT RESISTANCE: 30 MILLI OHMS MAX.
 8. INSULATION RESISTANCE: 1000 MEGA OHMS.
 9. OPERATING TEMPERATURE: -40 ° TO +85 °C
 10. DOUBLE TUNING FORK TYPE CONTACT, ACCOMMODATES .025"[0.64mm] SQ PINS. .100"[2.54mm] PITCH LOW-PROFILE MINI TYPE.

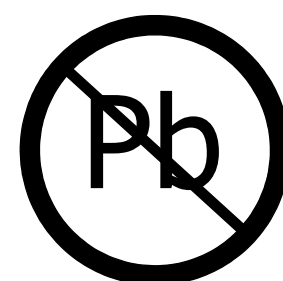

RoHS COMPLIANT

UNLESS OTHERWISE SPECIFIED: DIMENSIONS ARE IN INCHES [MM]		DRAWN	DATE	NAME		
TOLERANCES: ANGULAR: ± 30'			9/22/2011	JH		
.XX= ± .012 [.30] .XXX= ± .008 [.20] .XXXX= ± .004 [.10]		<small>THE INFORMATION HEREIN CONTAINS PROPRIETARY INFORMATION OF SULLINS ELECTRONICS AND IS NOT TO BE REPRODUCED, USED OR DISCLOSED TO OTHERS FOR ANY PURPOSE EXCEPT AS SPECIFICALLY AUTHORIZED IN WRITING BY AN OFFICER OF SULLINS ELECTRONICS.</small>			TITLE MINI SHUNT, .100" CC, OPEN TOP	
INTERPRET DIMENSIONS AND TOLERANCING PER: ASME Y14.5M-2009		<small>SCALE: 16:1</small>			PART NUMBER SPC02SXCN-RC	
		SIZE	CAGE CODE	DWG. NO.	REV	
		C	54453	11508	B	
		SHEET 1 OF 1				