



Chipsmall Limited consists of a professional team with an average of over 10 year of expertise in the distribution of electronic components. Based in Hongkong, we have already established firm and mutual-benefit business relationships with customers from,Europe,America and south Asia,supplying obsolete and hard-to-find components to meet their specific needs.

With the principle of “Quality Parts,Customers Priority,Honest Operation,and Considerate Service”,our business mainly focus on the distribution of electronic components. Line cards we deal with include Microchip,ALPS,ROHM,Xilinx,Pulse,ON,Everlight and Freescale. Main products comprise IC,Modules,Potentiometer,IC Socket,Relay,Connector.Our parts cover such applications as commercial,industrial, and automotives areas.

We are looking forward to setting up business relationship with you and hope to provide you with the best service and solution. Let us make a better world for our industry!



## Contact us

Tel: +86-755-8981 8866 Fax: +86-755-8427 6832

Email & Skype: info@chipsmall.com Web: www.chipsmall.com

Address: A1208, Overseas Decoration Building, #122 Zhenhua RD., Futian, Shenzhen, China





# SPC560P34L1, SPC560P34L3 SPC560P40L1, SPC560P40L3

32-bit Power Architecture<sup>®</sup> based MCU with 320 KB Flash memory and 20 KB RAM for automotive chassis and safety applications

Datasheet – production data

## Features

- Up to 64 MHz, single issue, 32-bit CPU core complex (e200z0h)
  - Compliant with Power Architecture<sup>®</sup> embedded category
  - Variable Length Encoding (VLE)
- Memory organization
  - Up to 256 KB on-chip code flash memory with ECC and erase/program controller
  - Additional 64 (4 × 16) KB on-chip data flash memory with ECC for EEPROM emulation
  - Up to 20 KB on-chip SRAM with ECC
- Fail-safe protection
  - Programmable watchdog timer
  - Non-maskable interrupt
  - Fault collection unit
- Nexus Class 1 interface
- Interrupts and events
  - 16-channel eDMA controller
  - 16 priority level controller
  - Up to 25 external interrupts
  - PIT implements four 32-bit timers
  - 120 interrupts are routed via INTC
- General purpose I/Os
  - Individually programmable as input, output or special function
  - 37 on LQFP64
  - 64 on LQFP100
- 1 general purpose eTimer unit
  - 6 timers each with up/down capabilities
  - 16-bit resolution, cascadable counters
  - Quadrature decode with rotation direction flag
  - Double buffer input capture and output compare

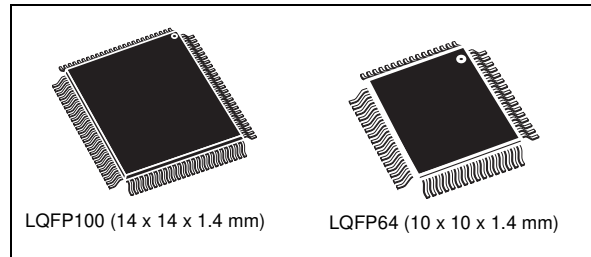

- Communications interfaces
  - 2 LINFlex channels (1× Master/Slave, 1× Master only)
  - Up to 3 DSPI channels with automatic chip select generation (up to 8/4/4 chip selects)
  - Up to 2 FlexCAN interface (2.0B Active) with 32 message buffers
  - 1 safety port based on FlexCAN with 32 message buffers and up to 8 Mbit/s at 64 MHz capability usable as second CAN when not used as safety port
- One 10-bit analog-to-digital converter (ADC)
  - Up to 16 input channels (16 on LQFP100 / 12 on LQFP64)
  - Conversion time < 1 μs including sampling time at full precision
  - Programmable Cross Triggering Unit (CTU)
  - 4 analog watchdogs with interrupt capability
- On-chip CAN/UART bootstrap loader with Boot Assist Module (BAM)
- 1 FlexPWM unit: 8 complementary or independent outputs with ADC synchronization signals

**Table 1. Device summary**

Package	Code flash memory	
	192 KB	256 KB
LQFP100	SPC560P34L3	SPC560P40L3
LQFP64	SPC560P34L1	SPC560P40L1

# Contents

<b>1</b>	<b>Introduction</b>	<b>7</b>
1.1	Document overview	7
1.2	Description	7
1.3	Device comparison	7
1.4	Block diagram	9
1.5	Feature details	13
1.5.1	High performance e200z0 core processor	13
1.5.2	Crossbar switch (XBAR)	13
1.5.3	Enhanced direct memory access (eDMA)	14
1.5.4	Flash memory	14
1.5.5	Static random access memory (SRAM)	15
1.5.6	Interrupt controller (INTC)	16
1.5.7	System status and configuration module (SSCM)	16
1.5.8	System clocks and clock generation	17
1.5.9	Frequency-modulated phase-locked loop (FMPLL)	17
1.5.10	Main oscillator	17
1.5.11	Internal RC oscillator	17
1.5.12	Periodic interrupt timer (PIT)	18
1.5.13	System timer module (STM)	18
1.5.14	Software watchdog timer (SWT)	18
1.5.15	Fault collection unit (FCU)	18
1.5.16	System integration unit – Lite (SIUL)	19
1.5.17	Boot and censorship	19
1.5.18	Error correction status module (ECSM)	19
1.5.19	Peripheral bridge (PBRIDGE)	20
1.5.20	Controller area network (FlexCAN)	20
1.5.21	Safety port (FlexCAN)	21
1.5.22	Serial communication interface module (LINFlex)	22
1.5.23	Deserial serial peripheral interface (DSPI)	23
1.5.24	Pulse width modulator (FlexPWM)	23
1.5.25	eTimer	25
1.5.26	Analog-to-digital converter (ADC) module	25
1.5.27	Cross triggering unit (CTU)	26
1.5.28	Nexus Development Interface (NDI)	26

1.5.29	Cyclic redundancy check (CRC)	27
1.5.30	IEEE 1149.1 JTAG controller	27
1.5.31	On-chip voltage regulator (VREG)	28
<b>2</b>	<b>Package pinouts and signal descriptions</b>	<b>29</b>
2.1	Package pinouts	29
2.2	Pin description	33
2.2.1	Power supply and reference voltage pins	33
2.2.2	System pins	34
2.2.3	Pin multiplexing	35
<b>3</b>	<b>Electrical characteristics</b>	<b>45</b>
3.1	Introduction	45
3.2	Parameter classification	45
3.3	Absolute maximum ratings	46
3.4	Recommended operating conditions	48
3.5	Thermal characteristics	52
3.5.1	Package thermal characteristics	52
3.5.2	General notes for specifications at maximum junction temperature	52
3.6	Electromagnetic interference (EMI) characteristics	54
3.7	Electrostatic discharge (ESD) characteristics	54
3.8	Power management electrical characteristics	54
3.8.1	Voltage regulator electrical characteristics	54
3.8.2	Voltage monitor electrical characteristics	57
3.9	Power up/down sequencing	57
3.10	DC electrical characteristics	59
3.10.1	NVUSRO register	59
3.10.2	DC electrical characteristics (5 V)	60
3.10.3	DC electrical characteristics (3.3 V)	62
3.10.4	Input DC electrical characteristics definition	63
3.10.5	I/O pad current specification	64
3.11	Main oscillator electrical characteristics	65
3.12	FMPLL electrical characteristics	66
3.13	16 MHz RC oscillator electrical characteristics	68
3.14	Analog-to-digital converter (ADC) electrical characteristics	68

3.14.1	Input impedance and ADC accuracy	69
3.14.2	ADC conversion characteristics	73
3.15	Flash memory electrical characteristics	74
3.15.1	Program/Erase characteristics	74
3.15.2	Flash memory power supply DC characteristics	75
3.15.3	Start-up/Switch-off timings	76
3.16	AC specifications	76
3.16.1	Pad AC specifications	76
3.17	AC timing characteristics	77
3.17.1	RESET pin characteristics	77
3.17.2	IEEE 1149.1 interface timing	80
3.17.3	Nexus timing	82
3.17.4	External interrupt timing (IRQ pin)	84
3.17.5	DSPI timing	85
<b>4</b>	<b>Package characteristics</b>	<b>91</b>
4.1	ECOPACK®	91
4.2	Package mechanical data	92
4.2.1	LQFP100 mechanical outline drawing	92
4.2.2	LQFP64 mechanical outline drawing	94
<b>5</b>	<b>Ordering information</b>	<b>96</b>
<b>Appendix A Abbreviations</b>		<b>97</b>
<b>Revision history</b>		<b>98</b>

## List of tables

Table 1.	Device summary . . . . .	1
Table 2.	SPC560P34/SPC560P40 device comparison . . . . .	7
Table 3.	SPC560P40 device configuration differences . . . . .	9
Table 4.	SPC560P34/SPC560P40 series block summary . . . . .	11
Table 5.	Supply pins . . . . .	33
Table 6.	System pins . . . . .	34
Table 7.	Pin muxing . . . . .	35
Table 8.	Parameter classifications . . . . .	45
Table 9.	Absolute maximum ratings . . . . .	46
Table 10.	Recommended operating conditions (5.0 V) . . . . .	48
Table 11.	Recommended operating conditions (3.3 V) . . . . .	49
Table 12.	LQFP thermal characteristics . . . . .	52
Table 13.	EMI testing specifications . . . . .	54
Table 14.	ESD ratings, . . . . .	54
Table 15.	Approved NPN ballast components . . . . .	55
Table 16.	Voltage regulator electrical characteristics . . . . .	56
Table 17.	Low voltage monitor electrical characteristics. . . . .	57
Table 18.	PAD3V5V field description . . . . .	59
Table 19.	DC electrical characteristics (5.0 V, NVUSRO[PAD3V5V] = 0) . . . . .	60
Table 20.	Supply current (5.0 V, NVUSRO[PAD3V5V] = 0) . . . . .	61
Table 21.	DC electrical characteristics (3.3 V, NVUSRO[PAD3V5V] = 1) . . . . .	62
Table 22.	Supply current (3.3 V, NVUSRO[PAD3V5V] = 1) . . . . .	63
Table 23.	I/O supply segment . . . . .	64
Table 24.	I/O consumption . . . . .	64
Table 25.	Main oscillator output electrical characteristics (5.0 V, NVUSRO[PAD3V5V] = 0) . . . . .	65
Table 26.	Main oscillator output electrical characteristics (3.3 V, NVUSRO[PAD3V5V] = 1) . . . . .	66
Table 27.	Input clock characteristics . . . . .	66
Table 28.	FMPLL electrical characteristics . . . . .	66
Table 29.	16 MHz RC oscillator electrical characteristics . . . . .	68
Table 30.	ADC conversion characteristics . . . . .	73
Table 31.	Program and erase specifications . . . . .	74
Table 32.	Flash memory module life . . . . .	75
Table 33.	Flash memory read access timing . . . . .	75
Table 34.	Flash memory power supply DC electrical characteristics . . . . .	75
Table 35.	Start-up time/Switch-off time . . . . .	76
Table 36.	Output pin transition times . . . . .	76
Table 37.	RESET electrical characteristics . . . . .	79
Table 38.	JTAG pin AC electrical characteristics . . . . .	80
Table 39.	Nexus debug port timing . . . . .	82
Table 40.	External interrupt timing . . . . .	84
Table 41.	DSPI timing . . . . .	85
Table 42.	LQFP100 package mechanical data . . . . .	93
Table 43.	LQFP64 package mechanical data . . . . .	94
Table 44.	Abbreviations . . . . .	97
Table 45.	Document revision history . . . . .	98

## List of figures

Figure 1.	Block diagram (SPC560P40 full-featured configuration)	10
Figure 2.	64-pin LQFP pinout – Full featured configuration (top view)	29
Figure 3.	64-pin LQFP pinout – Airbag configuration (top view)	30
Figure 4.	100-pin LQFP pinout – Full featured configuration (top view)	31
Figure 5.	100-pin LQFP pinout – Airbag configuration (top view)	32
Figure 6.	Power supplies constraints ( $-0.3\text{ V} \leq V_{DD\_HV\_IOx} \leq 6.0\text{ V}$ )	47
Figure 7.	Independent ADC supply ( $-0.3\text{ V} \leq V_{DD\_HV\_REG} \leq 6.0\text{ V}$ )	48
Figure 8.	Power supplies constraints ( $3.0\text{ V} \leq V_{DD\_HV\_IOx} \leq 5.5\text{ V}$ )	51
Figure 9.	Independent ADC supply ( $3.0\text{ V} \leq V_{DD\_HV\_REG} \leq 5.5\text{ V}$ )	51
Figure 10.	Voltage regulator configuration	55
Figure 11.	Power-up typical sequence	58
Figure 12.	Power-down typical sequence	58
Figure 13.	Brown-out typical sequence	59
Figure 14.	Input DC electrical characteristics definition	63
Figure 15.	ADC characteristics and error definitions	68
Figure 16.	Input equivalent circuit	70
Figure 17.	Transient behavior during sampling phase	70
Figure 18.	Spectral representation of input signal	72
Figure 19.	Pad output delay	77
Figure 20.	Start-up reset requirements	78
Figure 21.	Noise filtering on reset signal	78
Figure 22.	JTAG test clock input timing	80
Figure 23.	JTAG test access port timing	81
Figure 24.	JTAG boundary scan timing	82
Figure 25.	Nexus output timing	83
Figure 26.	Nexus event trigger and test clock timing	83
Figure 27.	Nexus TDI, TMS, TDO timing	84
Figure 28.	External interrupt timing	85
Figure 29.	DSPI classic SPI timing – Master, CPHA = 0	86
Figure 30.	DSPI classic SPI timing – Master, CPHA = 1	87
Figure 31.	DSPI classic SPI timing – Slave, CPHA = 0	87
Figure 32.	DSPI classic SPI timing – Slave, CPHA = 1	88
Figure 33.	DSPI modified transfer format timing – Master, CPHA = 0	88
Figure 34.	DSPI modified transfer format timing – Master, CPHA = 1	89
Figure 35.	DSPI modified transfer format timing – Slave, CPHA = 0	89
Figure 36.	DSPI modified transfer format timing – Slave, CPHA = 1	90
Figure 37.	DSPI PCS Strobe (PCSS) timing	90
Figure 38.	LQFP100 package mechanical drawing	92
Figure 39.	LQFP64 package mechanical drawing	94
Figure 40.	Commercial product code structure	96

# 1 Introduction

## 1.1 Document overview

This document provides electrical specifications, pin assignments, and package diagrams for the SPC560P34/40 series of microcontroller units (MCUs). It also describes the device features and highlights important electrical and physical characteristics. For functional characteristics, refer to the device reference manual.

## 1.2 Description

This 32-bit system-on-chip (SoC) automotive microcontroller family is the latest achievement in integrated automotive application controllers. It belongs to an expanding range of automotive-focused products designed to address chassis applications—specifically, electrical hydraulic power steering (EHPS) and electric power steering (EPS)—as well as airbag applications.

This family is one of a series of next-generation integrated automotive microcontrollers based on the Power Architecture technology.

The advanced and cost-efficient host processor core of this automotive controller family complies with the Power Architecture embedded category. It operates at speeds of up to 64 MHz and offers high performance processing optimized for low power consumption. It capitalizes on the available development infrastructure of current Power Architecture devices and is supported with software drivers, operating systems and configuration code to assist with users implementations.

## 1.3 Device comparison

[Table 2](#) provides a summary of different members of the SPC560P34/SPC560P40 family and their features—relative to full-featured version—to enable a comparison among the family members and an understanding of the range of functionality offered within this family.

**Table 2. SPC560P34/SPC560P40 device comparison**

Feature	SPC560P34 Full-featured	SPC560P40 Full-featured
Code flash memory (with ECC)	192 KB	256 KB
Data flash memory / EE option (with ECC)	64 KB	
SRAM (with ECC)	12 KB	20 KB
Processor core	32-bit e200z0h	
Instruction set	VLE (variable length encoding)	
CPU performance	0–64 MHz	
FMPLL (frequency-modulated phase-locked loop) module	1	
INTC (interrupt controller) channels	120	
PIT (periodic interrupt timer)	1 (with four 32-bit timers)	



**Table 2. SPC560P34/SPC560P40 device comparison (continued)**

Feature		SPC560P34 Full-featured	SPC560P40 Full-featured
eDMA (enhanced direct memory access) channels		16	
FlexCAN (controller area network)		1 <sup>(1)</sup>	2 <sup>(1),(2)</sup>
Safety port		No	Yes (via second FlexCAN module)
FCU (fault collection unit)		Yes	
CTU (cross triggering unit)		Yes	Yes
eTimer		1 (16-bit, 6 channels)	
FlexPWM (pulse-width modulation) channels		8 (capture capability not supported)	8 (capture capability not supported)
Analog-to-digital converter (ADC)		1 (10-bit, 16 channels)	
LINFlex		2 (1 × Master/Slave, 1 × Master only)	2 (1 × Master/Slave, 1 × Master only)
DSPI (deserial serial peripheral interface)		2	3
CRC (cyclic redundancy check) unit		Yes	
Junction temperature sensor		No	
JTAG controller		Yes	
Nexus port controller (NPC)		Yes (Nexus Class 1)	
Supply	Digital power supply <sup>(3)</sup>	3.3 V or 5 V single supply with external transistor	
	Analog power supply	3.3 V or 5 V	
	Internal RC oscillator	16 MHz	
	External crystal oscillator	4–40 MHz	
Packages		LQFP64 LQFP100	
Temperature	Standard ambient temperature	–40 to 125 °C	

1. Each FlexCAN module has 32 message buffers.
2. One FlexCAN module can act as a safety port with a bit rate as high as 8 Mbit/s at 64 MHz.
3. The different supply voltages vary according to the part number ordered.

SPC560P34/SPC560P40 is available in two configurations having different features: Full-featured and airbag. [Table 3](#) shows the main differences between the two versions of the SPC560P40 MCU.

**Table 3.** SPC560P40 device configuration differences

Feature	Configuration	
	Airbag	Full-featured
SRAM (with ECC)	16 KB	20 KB
FlexCAN (controller area network)	1	2
Safety port	No	Yes (via second FlexCAN module)
FlexPWM (pulse-width modulation) channels	No	8 (capture capability not supported)
CTU (cross triggering unit)	No	Yes

## 1.4 Block diagram

*Figure 1* shows a top-level block diagram of the SPC560P34/SPC560P40 MCU. *Table 2* summarizes the functions of the blocks.

Figure 1. Block diagram (SPC560P40 full-featured configuration)

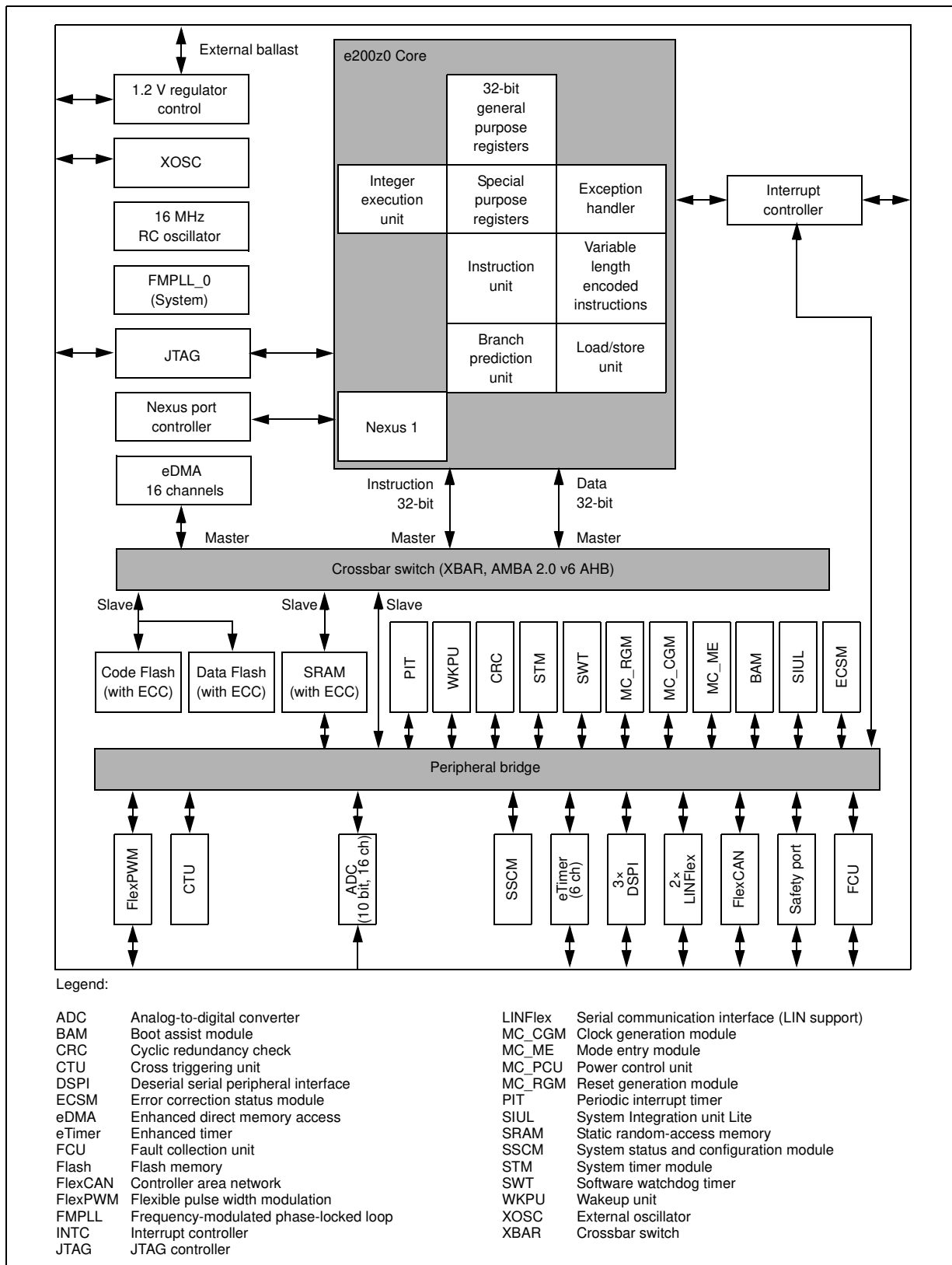

**Table 4. SPC560P34/SPC560P40 series block summary**

Block	Function
Analog-to-digital converter (ADC)	Multi-channel, 10-bit analog-to-digital converter
Boot assist module (BAM)	Block of read-only memory containing VLE code which is executed according to the boot mode of the device
Clock generation module (MC_CGM)	Provides logic and control required for the generation of system and peripheral clocks
Controller area network (FlexCAN)	Supports the standard CAN communications protocol
Cross triggering unit (CTU)	Enables synchronization of ADC conversions with a timer event from the eMIOS or from the PIT
Crossbar switch (XBAR)	Supports simultaneous connections between two master ports and three slave ports; supports a 32-bit address bus width and a 32-bit data bus width
Cyclic redundancy check (CRC)	CRC checksum generator
Deserial serial peripheral interface (DSPI)	Provides a synchronous serial interface for communication with external devices
Enhanced direct memory access (eDMA)	Performs complex data transfers with minimal intervention from a host processor via "n" programmable channels
Enhanced timer (eTimer)	Provides enhanced programmable up/down modulo counting
Error correction status module (ECSM)	Provides a myriad of miscellaneous control functions for the device including program-visible information about configuration and revision levels, a reset status register, wakeup control for exiting sleep modes, and optional features such as information on memory errors reported by error-correcting codes
External oscillator (XOSC)	Provides an output clock used as input reference for FMPLL_0 or as reference clock for specific modules depending on system needs
Fault collection unit (FCU)	Provides functional safety to the device
Flash memory	Provides non-volatile storage for program code, constants and variables
Frequency-modulated phase-locked loop (FMPLL)	Generates high-speed system clocks and supports programmable frequency modulation
Interrupt controller (INTC)	Provides priority-based preemptive scheduling of interrupt requests
JTAG controller	Provides the means to test chip functionality and connectivity while remaining transparent to system logic when not in test mode
LINFlex controller	Manages a high number of LIN (Local Interconnect Network protocol) messages efficiently with a minimum of CPU load
Mode entry module (MC_ME)	Provides a mechanism for controlling the device operational mode and mode transition sequences in all functional states; also manages the power control unit, reset generation module and clock generation module, and holds the configuration, control and status registers accessible for applications
Periodic interrupt timer (PIT)	Produces periodic interrupts and triggers
Peripheral bridge (PBRIDGE)	Is the interface between the system bus and on-chip peripherals
Power control unit (MC_PCU)	Reduces the overall power consumption by disconnecting parts of the device from the power supply via a power switching device; device components are grouped into sections called "power domains" which are controlled by the PCU

**Table 4. SPC560P34/SPC560P40 series block summary (continued)**

Block	Function
Pulse width modulator (FlexPWM)	Contains four PWM submodules, each of which capable of controlling a single half-bridge power stage and two fault input channels
Reset generation module (MC_RGM)	Centralizes reset sources and manages the device reset sequence of the device
Static random-access memory (SRAM)	Provides storage for program code, constants, and variables
System integration unit lite (SIUL)	Provides control over all the electrical pad controls and up 32 ports with 16 bits of bidirectional, general-purpose input and output signals and supports up to 32 external interrupts with trigger event configuration
System status and configuration module (SSCM)	Provides system configuration and status data (such as memory size and status, device mode and security status), device identification data, debug status port enable and selection, and bus and peripheral abort enable/disable
System timer module (STM)	Provides a set of output compare events to support AUTOSAR <sup>(1)</sup> and operating system tasks
System watchdog timer (SWT)	Provides protection from runaway code
Wakeup unit (WKPU)	Supports up to 18 external sources that can generate interrupts or wakeup events, of which 1 can cause non-maskable interrupt requests or wakeup events

1. AUTOSAR: AUTomotive Open System ARchitecture (see [www.autosar.org](http://www.autosar.org))

## 1.5 Feature details

### 1.5.1 High performance e200z0 core processor

The e200z0 Power Architecture core provides the following features:

- High performance e200z0 core processor for managing peripherals and interrupts
- Single issue 4-stage pipeline in-order execution 32-bit Power Architecture CPU
- Harvard architecture
- Variable length encoding (VLE), allowing mixed 16- and 32-bit instructions
  - Results in smaller code size footprint
  - Minimizes impact on performance
- Branch processing acceleration using lookahead instruction buffer
- Load/store unit
  - 1-cycle load latency
  - Misaligned access support
  - No load-to-use pipeline bubbles
- Thirty-two 32-bit general purpose registers (GPRs)
- Separate instruction bus and load/store bus Harvard architecture
- Hardware vectored interrupt support
- Reservation instructions for implementing read-modify-write constructs
- Long cycle time instructions, except for guarded loads, do not increase interrupt latency
- Extensive system development support through Nexus debug port
- Non-maskable interrupt support

### 1.5.2 Crossbar switch (XBAR)

The XBAR multi-port crossbar switch supports simultaneous connections between three master ports and three slave ports. The crossbar supports a 32-bit address bus width and a 32-bit data bus width.

The crossbar allows for two concurrent transactions to occur from any master port to any slave port; but one of those transfers must be an instruction fetch from internal flash memory. If a slave port is simultaneously requested by more than one master port, arbitration logic will select the higher priority master and grant it ownership of the slave port. All other masters requesting that slave port will be stalled until the higher priority master completes its transactions. Requesting masters will be treated with equal priority and will be granted access a slave port in round-robin fashion, based upon the ID of the last master to be granted access.

The crossbar provides the following features:

- 3 master ports:
  - e200z0 core complex instruction port
  - e200z0 core complex Load/Store Data port
  - eDMA
- 3 slave ports:
  - Flash memory (Code and Data)
  - SRAM
  - Peripheral bridge
- 32-bit internal address, 32-bit internal data paths
- Fixed Priority Arbitration based on Port Master
- Temporary dynamic priority elevation of masters

### 1.5.3 Enhanced direct memory access (eDMA)

The enhanced direct memory access (eDMA) controller is a second-generation module capable of performing complex data movements via 16 programmable channels, with minimal intervention from the host processor. The hardware micro architecture includes a DMA engine which performs source and destination address calculations, and the actual data movement operations, along with an SRAM-based memory containing the transfer control descriptors (TCD) for the channels.

The eDMA module provides the following features:

- 16 channels support independent 8-, 16- or 32-bit single value or block transfers
- Supports variable-sized queues and circular queues
- Source and destination address registers are independently configured to either post-increment or to remain constant
- Each transfer is initiated by a peripheral, CPU, or eDMA channel request
- Each eDMA channel can optionally send an interrupt request to the CPU on completion of a single value or block transfer
- DMA transfers possible between system memories, DSPs, ADC, FlexPWM, eTimer and CTU
- Programmable DMA channel multiplexer allows assignment of any DMA source to any available DMA channel with as many as 30 request sources
- eDMA abort operation through software

### 1.5.4 Flash memory

The SPC560P34/SPC560P40 provides 320 KB of programmable, non-volatile, flash memory. The non-volatile memory (NVM) can be used for instruction and/or data storage. The flash memory module is interfaced to the system bus by a dedicated flash memory controller. It supports a 32-bit data bus width at the system bus port, and a 128-bit read data interface to flash memory. The module contains four 128-bit wide prefetch buffers. Prefetch buffer hits allow no-wait responses. Normal flash memory array accesses are registered and are forwarded to the system bus on the following cycle, incurring two wait-states.

The flash memory module provides the following features:

- As much as 320 KB flash memory
  - 6 blocks (32 KB + 2×16 KB + 32 KB + 32 KB + 128 KB) code flash memory
  - 4 blocks (16 KB + 16 KB + 16 KB + 16 KB) data flash memory
  - Full Read-While-Write (RWW) capability between code flash memory and data flash memory
- Four 128-bit wide prefetch buffers to provide single cycle in-line accesses (prefetch buffers can be configured to prefetch code or data or both)
- Typical flash memory access time: no wait-state for buffer hits, 2 wait-states for page buffer miss at 64 MHz
- Hardware managed flash memory writes handled by 32-bit RISC Krypton engine
- Hardware and software configurable read and write access protections on a per-master basis
- Configurable access timing allowing use in a wide range of system frequencies
- Multiple-mapping support and mapping-based block access timing (up to 31 additional cycles) allowing use for emulation of other memory types
- Software programmable block program/erase restriction control
- Erase of selected block(s)
- Read page sizes
  - Code flash memory: 128 bits (4 words)
  - Data flash memory: 32 bits (1 word)
- ECC with single-bit correction, double-bit detection for data integrity
  - Code flash memory: 64-bit ECC
  - Data flash memory: 32-bit ECC
- Embedded hardware program and erase algorithm
- Erase suspend and program abort
- Censorship protection scheme to prevent flash memory content visibility
- Hardware support for EEPROM emulation

### 1.5.5 Static random access memory (SRAM)

The SPC560P34/SPC560P40 SRAM module provides up to 20 KB of general-purpose memory.

The SRAM module provides the following features:

- Supports read/write accesses mapped to the SRAM from any master
- Up to 20 KB general purpose SRAM
- Supports byte (8-bit), half word (16-bit), and word (32-bit) writes for optimal use of memory
- Typical SRAM access time: no wait-state for reads and 32-bit writes; 1 wait-state for 8- and 16-bit writes if back-to-back with a read to same memory block



### 1.5.6 Interrupt controller (INTC)

The interrupt controller (INTC) provides priority-based preemptive scheduling of interrupt requests, suitable for statically scheduled hard real-time systems. The INTC handles 128 selectable-priority interrupt sources.

For high-priority interrupt requests, the time from the assertion of the interrupt request by the peripheral to the execution of the interrupt service routine (ISR) by the processor has been minimized. The INTC provides a unique vector for each interrupt request source for quick determination of which ISR has to be executed. It also provides a wide number of priorities so that lower priority ISRs do not delay the execution of higher priority ISRs. To allow the appropriate priorities for each source of interrupt request, the priority of each interrupt request is software configurable.

When multiple tasks share a resource, coherent accesses to that resource need to be supported. The INTC supports the priority ceiling protocol (PCP) for coherent accesses. By providing a modifiable priority mask, the priority can be raised temporarily so that all tasks which share the same resource can not preempt each other.

The INTC provides the following features:

- Unique 9-bit vector for each separate interrupt source
- 8 software triggerable interrupt sources
- 16 priority levels with fixed hardware arbitration within priority levels for each interrupt source
- Ability to modify the ISR or task priority: modifying the priority can be used to implement the priority ceiling protocol for accessing shared resources.
- 1 external high priority interrupt (NMI) directly accessing the main core and I/O processor (IOP) critical interrupt mechanism

### 1.5.7 System status and configuration module (SSCM)

The system status and configuration module (SSCM) provides central device functionality.

The SSCM includes these features:

- System configuration and status
  - Memory sizes/status
  - Device mode and security status
  - Determine boot vector
  - Search code flash for bootable sector
  - DMA status
- Debug status port enable and selection
- Bus and peripheral abort enable/disable

### 1.5.8 System clocks and clock generation

The following list summarizes the system clock and clock generation on the SPC560P34/SPC560P40:

- Lock detect circuitry continuously monitors lock status
- Loss of clock (LOC) detection for PLL outputs
- Programmable output clock divider ( $\div 1$ ,  $\div 2$ ,  $\div 4$ ,  $\div 8$ )
- FlexPWM module and eTimer module running at the same frequency as the e200z0h core
- Internal 16 MHz RC oscillator for rapid start-up and safe mode: supports frequency trimming by user application

### 1.5.9 Frequency-modulated phase-locked loop (FMPLL)

The FMPLL allows the user to generate high speed system clocks from a 4–40 MHz input clock. Further, the FMPLL supports programmable frequency modulation of the system clock. The PLL multiplication factor, output clock divider ratio are all software configurable.

The FMPLL has the following major features:

- Input clock frequency: 4–40 MHz
- Maximum output frequency: 64 MHz
- Voltage controlled oscillator (VCO)—frequency 256–512 MHz
- Reduced frequency divider (RFD) for reduced frequency operation without forcing the FMPLL to relock
- Frequency-modulated PLL
  - Modulation enabled/disabled through software
  - Triangle wave modulation
- Programmable modulation depth ( $\pm 0.25\%$  to  $\pm 4\%$  deviation from center frequency): programmable modulation frequency dependent on reference frequency
- Self-locked mode (SCM) operation

### 1.5.10 Main oscillator

The main oscillator provides these features:

- Input frequency range: 4–40 MHz
- Crystal input mode or oscillator input mode
- PLL reference

### 1.5.11 Internal RC oscillator

This device has an RC ladder phase-shift oscillator. The architecture uses constant current charging of a capacitor. The voltage at the capacitor is compared by the stable bandgap reference voltage.

The RC oscillator provides these features:

- Nominal frequency 16 MHz
- $\pm 5\%$  variation over voltage and temperature after process trim
- Clock output of the RC oscillator serves as system clock source in case loss of lock or loss of clock is detected by the PLL
- RC oscillator is used as the default system clock during startup

### 1.5.12 Periodic interrupt timer (PIT)

The PIT module implements these features:

- 4 general-purpose interrupt timers
- 32-bit counter resolution
- Clocked by system clock frequency
- Each channel usable as trigger for a DMA request

### 1.5.13 System timer module (STM)

The STM implements these features:

- One 32-bit up counter with 8-bit prescaler
- Four 32-bit compare channels
- Independent interrupt source for each channel
- Counter can be stopped in debug mode

### 1.5.14 Software watchdog timer (SWT)

The SWT has the following features:

- 32-bit time-out register to set the time-out period
- Programmable selection of window mode or regular servicing
- Programmable selection of reset or interrupt on an initial time-out
- Master access protection
- Hard and soft configuration lock bits
- Reset configuration inputs allow timer to be enabled out of reset

### 1.5.15 Fault collection unit (FCU)

The FCU provides an independent fault reporting mechanism even if the CPU is malfunctioning.

The FCU module has the following features:

- FCU status register reporting the device status
- Continuous monitoring of critical fault signals
- User selection of critical signals from different fault sources inside the device
- Critical fault events trigger 2 external pins (user selected signal protocol) that can be used externally to reset the device and/or other circuitry (for example, a safety relay)
- Faults are latched into a register

### 1.5.16 System integration unit – Lite (SIUL)

The SPC560P34/SPC560P40 SIUL controls MCU pad configuration, external interrupt, general purpose I/O (GPIO), and internal peripheral multiplexing.

The pad configuration block controls the static electrical characteristics of I/O pins. The GPIO block provides uniform and discrete input/output control of the I/O pins of the MCU.

The SIUL provides the following features:

- Centralized general purpose input output (GPIO) control of up to 49 input/output pins and 16 analog input-only pads (package dependent)
- All GPIO pins can be independently configured to support pull-up, pull-down, or no pull
- Reading and writing to GPIO supported both as individual pins and 16-bit wide ports
- All peripheral pins, except ADC channels, can be alternatively configured as both general purpose input or output pins
- ADC channels support alternative configuration as general purpose inputs
- Direct readback of the pin value is supported on all pins through the SIUL
- Configurable digital input filter that can be applied to some general purpose input pins for noise elimination
- Up to 4 internal functions can be multiplexed onto 1 pin

### 1.5.17 Boot and censorship

Different booting modes are available in the SPC560P34/SPC560P40: booting from internal flash memory and booting via a serial link.

The default booting scheme uses the internal flash memory (an internal pull-down resistor is used to select this mode). Optionally, the user can boot via FlexCAN or LINFlex (using the boot assist module software).

A censorship scheme is provided to protect the content of the flash memory and offer increased security for the entire device.

A password mechanism is designed to grant the legitimate user access to the non-volatile memory.

#### Boot assist module (BAM)

The BAM is a block of read-only memory that is programmed once and is identical for all SPC560Pxx devices that are based on the e200z0h core. The BAM program is executed every time the device is powered on if the alternate boot mode has been selected by the user.

The BAM provides the following features:

- Serial bootloading via FlexCAN or LINFlex
- Ability to accept a password via the used serial communication channel to grant the legitimate user access to the non-volatile memory

### 1.5.18 Error correction status module (ECSM)

The ECSM provides a myriad of miscellaneous control functions regarding program-visible information about the platform configuration and revision levels, a reset status register, a software watchdog timer, wakeup control for exiting sleep modes, and information on

platform memory errors reported by error-correcting codes and/or generic access error information for certain processor cores.

The Error Correction Status Module supports a number of miscellaneous control functions for the platform. The ECSCM includes these features:

- Registers for capturing information on platform memory errors if error-correcting codes (ECC) are implemented
- For test purposes, optional registers to specify the generation of double-bit memory errors are enabled on the SPC560P34/SPC560P40.

The sources of the ECC errors are:

- Flash memory
- SRAM

### 1.5.19 Peripheral bridge (PBRIDGE)

The PBRIDGE implements the following features:

- Duplicated periphery
- Master access privilege level per peripheral (per master: read access enable; write access enable)
- Write buffering for peripherals
- Checker applied on PBRIDGE output toward periphery
- Byte endianness swap capability

### 1.5.20 Controller area network (FlexCAN)

The SPC560P34/SPC560P40 MCU contains one controller area network (FlexCAN) module. This module is a communication controller implementing the CAN protocol according to Bosch Specification version 2.0B. The CAN protocol was designed to be used primarily as a vehicle serial data bus, meeting the specific requirements of this field: real-time processing, reliable operation in the EMI environment of a vehicle, cost-effectiveness and required bandwidth. The FlexCAN module contains 32 message buffers.

The FlexCAN module provides the following features:

- Full implementation of the CAN protocol specification, version 2.0B
  - Standard data and remote frames
  - Extended data and remote frames
  - Up to 8-bytes data length
  - Programmable bit rate up to 1 Mbit/s
- 32 message buffers of up to 8-bytes data length
- Each message buffer configurable as Rx or Tx, all supporting standard and extended messages
- Programmable loop-back mode supporting self-test operation
- 3 programmable mask registers
- Programmable transmit-first scheme: lowest ID or lowest buffer number
- Time stamp based on 16-bit free-running timer
- Global network time, synchronized by a specific message
- Maskable interrupts
- Independent of the transmission medium (an external transceiver is assumed)
- High immunity to EMI
- Short latency time due to an arbitration scheme for high-priority messages
- Transmit features
  - Supports configuration of multiple mailboxes to form message queues of scalable depth
  - Arbitration scheme according to message ID or message buffer number
  - Internal arbitration to guarantee no inner or outer priority inversion
  - Transmit abort procedure and notification
- Receive features
  - Individual programmable filters for each mailbox
  - 8 mailboxes configurable as a 6-entry receive FIFO
  - 8 programmable acceptance filters for receive FIFO
- Programmable clock source
  - System clock
  - Direct oscillator clock to avoid PLL jitter

### 1.5.21 Safety port (FlexCAN)

The SPC560P34/SPC560P40 MCU has a second CAN controller synthesized to run at high bit rates to be used as a safety port. The CAN module of the safety port provides the following features:

- Identical to the FlexCAN module
- Bit rate up to 8 Mbit/s at 64 MHz CPU clock using direct connection between CAN modules (no physical transceiver required)
- 32 message buffers of up to 8-bytes data length
- Can be used as a second independent CAN module

### 1.5.22 Serial communication interface module (LINFlex)

The LINFlex (local interconnect network flexible) on the SPC560P34/SPC560P40 features the following:

- Supports LIN Master mode (both instances), LIN Slave mode (only one instance) and UART mode
- LIN state machine compliant to LIN1.3, 2.0 and 2.1 specifications
- Handles LIN frame transmission and reception without CPU intervention
- LIN features
  - Autonomous LIN frame handling
  - Message buffer to store Identifier and up to 8 data bytes
  - Supports message length of up to 64 bytes
  - Detection and flagging of LIN errors (sync field, delimiter, ID parity, bit framing, checksum, and time-out)
  - Classic or extended checksum calculation
  - Configurable Break duration of up to 36-bit times
  - Programmable baud rate prescalers (13-bit mantissa, 4-bit fractional)
  - Diagnostic features: Loop back; Self Test; LIN bus stuck dominant detection
  - Interrupt-driven operation with 16 interrupt sources
- LIN slave mode features:
  - Autonomous LIN header handling
  - Autonomous LIN response handling
  - Optional discarding of irrelevant LIN responses using ID filter
- UART mode:
  - Full-duplex operation
  - Standard non return-to-zero (NRZ) mark/space format
  - Data buffers with 4-byte receive, 4-byte transmit
  - Configurable word length (8-bit or 9-bit words)
  - Error detection and flagging
  - Parity, Noise and Framing errors
  - Interrupt-driven operation with four interrupt sources
  - Separate transmitter and receiver CPU interrupt sources
  - 16-bit programmable baud-rate modulus counter and 16-bit fractional
  - 2 receiver wake-up methods

### 1.5.23 Deserial serial peripheral interface (DSPI)

The deserial serial peripheral interface (DSPI) module provides a synchronous serial interface for communication between the SPC560P34/SPC560P40 MCU and external devices.

The DSPI modules provide these features:

- Full duplex, synchronous transfers
- Master or slave operation
- Programmable master bit rates
- Programmable clock polarity and phase
- End-of-transmission interrupt flag
- Programmable transfer baud rate
- Programmable data frames from 4 to 16 bits
- Up to 8 chip select lines available:
  - 8 on DSPI\_0
  - 4 each on DSPI\_1 and DSPI\_2
- 8 clock and transfer attributes registers
- Chip select strobe available as alternate function on one of the chip select pins for deglitching
- FIFOs for buffering up to 4 transfers on the transmit and receive side
- Queueing operation possible through use of the I/O processor or eDMA
- General purpose I/O functionality on pins when not used for SPI

### 1.5.24 Pulse width modulator (FlexPWM)

The pulse width modulator module (PWM) contains four PWM submodules each of which is set up to control a single half-bridge power stage. There are also three fault channels.

This PWM is capable of controlling most motor types: AC induction motors (ACIM), permanent magnet AC motors (PMAC), both brushless (BLDC) and brush DC motors (BDC), switched (SRM) and variable reluctance motors (VRM), and stepper motors.



The FlexPWM block implements the following features:

- 16-bit resolution for center, edge-aligned, and asymmetrical PWMs
- Clock frequency same as that used for e200z0h core
- PWM outputs can operate as complementary pairs or independent channels
- Can accept signed numbers for PWM generation
- Independent control of both edges of each PWM output
- Synchronization to external hardware or other PWM supported
- Double buffered PWM registers
  - Integral reload rates from 1 to 16
  - Half cycle reload capability
- Multiple ADC trigger events can be generated per PWM cycle via hardware
- Write protection for critical registers
- Fault inputs can be assigned to control multiple PWM outputs
- Programmable filters for fault inputs
- Independently programmable PWM output polarity
- Independent top and bottom deadtime insertion
- Each complementary pair can operate with its own PWM frequency and deadtime values
- Individual software-control for each PWM output
- All outputs can be programmed to change simultaneously via a “Force Out” event
- PWMX pin can optionally output a third PWM signal from each submodule
- Channels not used for PWM generation can be used for buffered output compare functions
- Channels not used for PWM generation can be used for input capture functions
- Enhanced dual-edge capture functionality
- eDMA support with automatic reload
- 2 fault inputs
- Capture capability for PWMA, PWMB, and PWMX channels not supported

### 1.5.25 eTimer

The SPC560P34/SPC560P40 includes one eTimer module which provides six 16-bit general purpose up/down timer/counter units with the following features:

- Clock frequency same as that used for the e200z0h core
- Individual channel capability
  - Input capture trigger
  - Output compare
  - Double buffer (to capture rising edge and falling edge)
  - Separate prescaler for each counter
  - Selectable clock source
  - 0–100% pulse measurement
  - Rotation direction flag (quad decoder mode)
- Maximum count rate
  - External event counting: max. count rate = peripheral clock/2
  - Internal clock counting: max. count rate = peripheral clock
- Counters are:
  - Cascadable
  - Preloadable
- Programmable count modulo
- Quadrature decode capabilities
- Counters can share available input pins
- Count once or repeatedly
- Pins available as GPIO when timer functionality not in use

### 1.5.26 Analog-to-digital converter (ADC) module

The ADC module provides the following features:

Analog part:

- 1 on-chip analog-to-digital converter
  - 10-bit AD resolution
  - 1 sample and hold unit
  - Conversion time, including sampling time, less than 1  $\mu$ s (at full precision)
  - Typical sampling time is 150 ns minimum (at full precision)
  - DNL/INL  $\pm$ 1 LSB
  - TUE < 1.5 LSB
  - Single-ended input signal up to 3.3 V/5.0 V
  - 3.3 V/5.0 V input reference voltage
  - ADC and its reference can be supplied with a voltage independent from  $V_{DDIO}$
  - ADC supply can be equal or higher than  $V_{DDIO}$
  - ADC supply and ADC reference are not independent from each other (both internally bonded to same pad)
  - Sample times of 2 (default), 8, 64 or 128 ADC clock cycles