



Chipsmall Limited consists of a professional team with an average of over 10 year of expertise in the distribution of electronic components. Based in Hongkong, we have already established firm and mutual-benefit business relationships with customers from,Europe,America and south Asia,supplying obsolete and hard-to-find components to meet their specific needs.

With the principle of “Quality Parts,Customers Priority,Honest Operation,and Considerate Service”,our business mainly focus on the distribution of electronic components. Line cards we deal with include Microchip,ALPS,ROHM,Xilinx,Pulse,ON,Everlight and Freescale. Main products comprise IC,Modules,Potentiometer,IC Socket,Relay,Connector.Our parts cover such applications as commercial,industrial, and automotives areas.

We are looking forward to setting up business relationship with you and hope to provide you with the best service and solution. Let us make a better world for our industry!



Contact us

Tel: +86-755-8981 8866 Fax: +86-755-8427 6832

Email & Skype: info@chipsmall.com Web: www.chipsmall.com

Address: A1208, Overseas Decoration Building, #122 Zhenhua RD., Futian, Shenzhen, China



Low-Profile, Top-Ported Digital SiSonic™ Microphone

The SPH0644HM4H-1 is a miniature, high-performance, low power, top port silicon digital microphone with a single-bit PDM output. Using Knowles' proven high performance SiSonic™ MEMS technology, the SPH0644HM4H-1 consists of an acoustic sensor, a low noise input buffer, and a sigma-delta modulator. These devices are suitable for applications such as cellphones, smart phones, laptop computers, sensors, digital still cameras, portable music recorders, and other portable electronic devices where excellent wideband audio performance and RF immunity are required. The high Signal-to-Noise Ratio (SNR) of the SPH0644HM4H-1 enhances the performance of far-field applications and many complex, multi-microphone algorithms. In addition, the SPH0644HM4H-1 offers multiple performance modes.

Product Features

- Very Low Profile (0.85mm Height)
- Standard 3.50mm x 2.65mm package size
- Sensitivity Matching
- Flat Frequency Response up to 10kHz
- Multiple performance modes (Sleep, Low-Power, Performance)
- Low Current Consumption of 240uA in Low-Power Mode
- PDM Output
- Supports Dual Multiplexed Channels
- High Drive Capability
- Ultra-Stable Performance
- Standard SMD Reflow
- Omnidirectional
- RF Shielded

Typical Applications

- Portable electronics
- Cellphones
- Laptop Computers
- Tablets
- Digital Still Cameras
- Portable Music Recorders

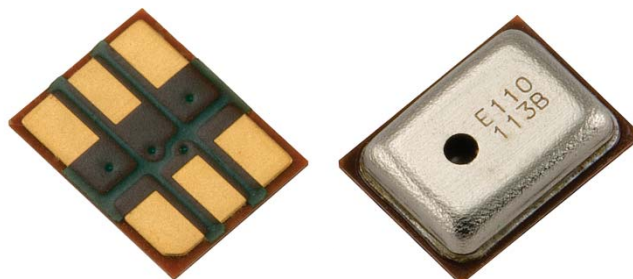

Absolute Maximum Ratings

Table 1: Absolute Maximum Ratings

Parameter	Absolute Maximum Rating	Units
Vdd, DATA to Ground	-0.3, +5.0	V
CLOCK to Ground	-0.3, +5.0	V
SELECT to Ground	-0.3, +5.0	V
Input Current	±5	mA
Short Circuit to/from DATA	Indefinite to Ground or Vdd	sec
Temperature	-40 to +100	°C

Stresses exceeding these “Absolute Maximum Ratings” may cause permanent damage to the device. These are stress ratings only. Functional operation at these or any other conditions beyond those indicated under “Acoustic & Electrical Specifications” is not implied. Exposure beyond those indicated under “Acoustic & Electrical Specifications” for extended periods may affect device reliability.

Acoustic & Electrical Specifications

Table 2: General Microphone Specifications

Test Conditions: 23±2°C, 55±20% R.H., Vdd=1.8V, Fclock=2.4MHz, Tedge≤3ns, SEL grounded, no load, unless otherwise indicated

Parameter	Symbol	Conditions	Min	Typ	Max	Units
Supply Voltage	Vdd		1.6	1.8	3.6	V
DC Output		Fullscale = ±100	-	0	-	% FS
Directivity			Omnidirectional			
Polarity		Increasing sound pressure	Increasing density of 1's			
Data Format			½ Cycle PDM			
Sensitivity Drop	ΔS	Vdd(min) < Vdd < Vdd(max)	-	-	±0.25	dB
Clock Input Capacitance	Cin		-	5	-	pF
SELECT (high)			Vdd-0.2	-	3.6	V
SELECT (low)			-0.3	-	0.2	V
Short Circuit Current	Isc	Grounded DATA pin	1	-	20	mA
Output Load	Cload		-	-	140	pF
Fall-asleep Time ^{3,4}		Fclock < 250 kHz	-	-	10	ms
Wake-up Time ^{3,5}		Fclock ≥ 500 kHz	-	-	35	ms
Startup Time ³		Powered Down → Active Mode	-	-	50	ms
Mode Change Time ³			-	-	15	ms

Table 3: Performance Mode Microphone Specifications

Test Conditions: 23±2°C, 55±20% R.H., Vdd=1.8V, Fclock=2.4MHz, Tedge≤3ns, SEL grounded, no load, unless otherwise indicated

Parameter	Symbol	Conditions	Min	Typ	Max	Units
Supply Current ^{1,2}	Idd	Vdd = 1.8V	-	925	1025	μA
Supply Current ²	Idd	Vdd = 3.6V	-	1015	-	μA
Sensitivity ¹	S	94 dB SPL @ 1 kHz	-37	-36	-35	dBFS
Signal to Noise Ratio ¹¹	SNR	94 dB SPL @ 1 kHz, A-weighted	-	58	-	dB(A)
Total Harmonic Distortion	THD	94 dB SPL @ 1 kHz, S = Typ	-	0.05	-	%
Total Harmonic Distortion	THD	115 dB SPL @ 1 kHz, S = Typ	-	0.25	-	%
Acoustic Overload Point	AOP	10% THD @ 1 kHz, S = Typ	-	131	-	dB SPL
Power Supply Rejection Ratio	PSRR	200 mVpp sinewave @ 1 kHz	-	85	-	dBV/FS
Power Supply Rejection	PSR + N	100mVpp square wave @ 217 Hz, A-weighted	-	-94	-	dBFS(A)

Table 4: Low-Power Mode Microphone Specifications

Test Conditions: 23±2°C, 55±20% R.H., Vdd=1.8V, Fclock=768kHz, Tedge≤3ns, SEL grounded, no load, unless otherwise indicated

Parameter	Symbol	Conditions	Min	Typ	Max	Units
Supply Current ²	I _{dd}	V _{dd} = 1.8V	-	255	-	μA
Supply Current ²	I _{dd}	V _{dd} = 3.6V	-	295	-	μA
Sensitivity	S	94 dB SPL @ 1 kHz	-21	-20	-19	dBFS
Signal to Noise Ratio ¹¹	SNR	94 dB SPL @ 1 kHz, A-weighted (20 Hz – 8 kHz)	-	58	-	dB(A)
Total Harmonic Distortion	THD	94 dB SPL @ 1 kHz, S = Typ	-	.05	-	%
Acoustic Overload Point	AOP	10% THD @ 1 kHz, S = Typ	-	114	-	dB SPL
Power Supply Rejection Ratio	PSRR	200 mVpp sinewave @ 1 kHz	-	68	-	dBV/FS
Power Supply Rejection	PSR + N	100mVpp square wave @ 217 Hz, A-weighted	-	-74	-	dBFS(A)

Table 5: Sleep Mode Microphone Specifications

Test Conditions: 23±2°C, 55±20% R.H., Vdd=1.8V, Fclock=250kHz, Tedge≤3ns, SEL grounded, no load, unless otherwise indicated

Parameter	Symbol	Conditions	Min	Typ	Max	Units
Clock Frequency	Fclock		0	0	250	kHz
Sleep Current	I _{sleep}	Fclock < 1 kHz, V _{dd} = 1.8V	-	52	-	μA
Sleep Current ¹	I _{sleep}	Fclock < 1 kHz, V _{dd} = 3.6V	-	62	-	μA

Table 6: Digital Interface Specifications

Test Conditions: 23 ±2°C, 55±20% R.H., Vdd=1.8V, Tedge≤3ns, unless otherwise indicated

Parameter	Symbol	Conditions	Min	Typ	Max	Units
Logic Input High ⁷	V _{ih}		0.65xV _{dd}	-	3.6	V
Logic Input Low ⁷	V _{il}		-0.3	-	0.35xV _{dd}	V
Logic Output High ⁷	V _{oh}	I _{OUT} = 2 mA	V _{dd} -0.45	-	V _{dd}	V
Logic Output Low ⁷	V _{ol}	I _{OUT} = 2 mA	0	-	0.45	V
Low→High Threshold ⁸	V _{l-h}		-	-	0.65xV _{dd}	V
High→Low Threshold ⁸	V _{h-l}		0.35xV _{dd}	-	-	V
Hysteresis Width ⁸	V _{hyst}		0.05xV _{dd}	-	0.20xV _{dd}	V
Clock Frequency	Fclock	Sleep Mode	0	0	250	kHz
		Low Power Mode	500	768	1200	
		Performance Mode	1400	2400	4800	
Clock Duty Cycle ¹⁰	D.C.		40	50	60	%
		2.4 MHz ≤ Fclock ≤ 4.8 MHz	48	50	52	
Clock Startup Delay		Time from V _{dd} > 1V to first clock edge	-	-	130	μs
Delay Time to Data Line Driven ⁷	T _{dd}		18	-	35	ns
Delay Time to Valid Data ⁷	T _{dv}	Max Load	-	-	100	ns
Delay Time to High Z ^{7,9}	T _{dz}		5	-	16	ns

¹ 100% tested.

² I_{dd} varies with Cload according to: ΔI_{dd} = 0.5*V_{dd}*ΔCload*Fclock.

³ Valid microphone states are: Powered Down Mode (mic off), Sleep Mode (low current, DATA = high-Z, fast startup), and Performance Mode (normal operation)

⁴ Time from Fclock < 250 kHz to I_{sleep} specification is met when transitioning from Active Mode to Sleep Mode.

⁵ Time from Fclock ≥ 500kHz to all applicable specifications are met when transitioning from Sleep Mode to Active Mode.

⁶ Thold can be dependent on Cload.

⁷ See Figure 1: Timing Diagram.

⁸ See Figure 2: Hysteresis Diagram.

⁹ Thold can be dependent on Cload.

¹⁰ For Fclock ≥ 3MHz, 48% < Clock Duty Cycle < 52%, otherwise THD and SNR will degrade.

¹¹ OSR = 64

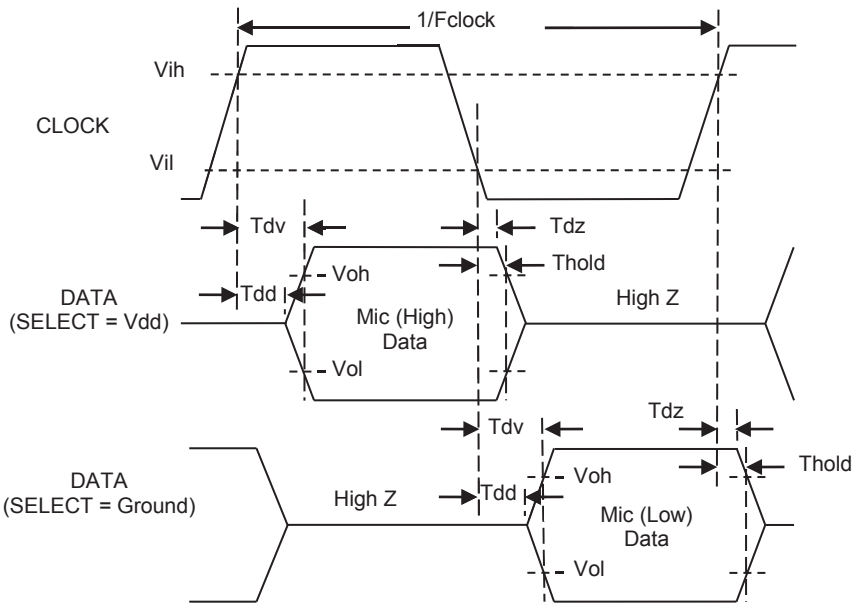

Figure 1: Timing Diagram

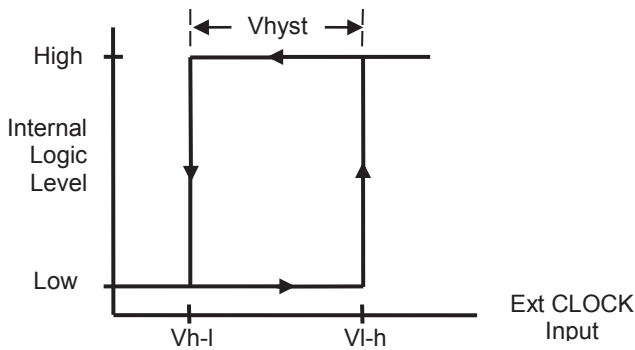

Figure 2: Hysteresis Diagram

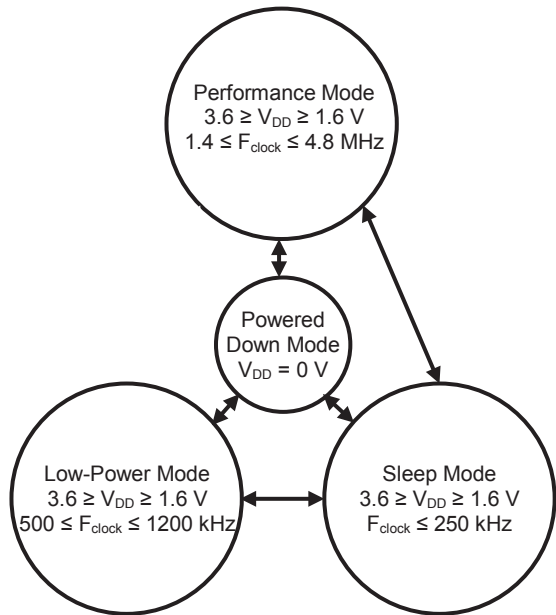

Figure 3: State Diagram

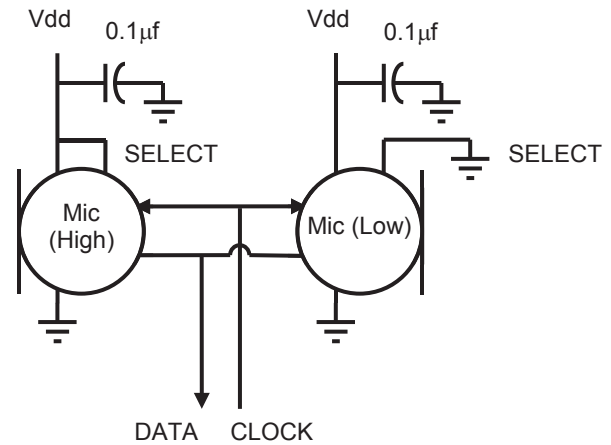

Figure 4: Typical Application Circuit

Notes: All Ground pins must be connected to ground.

Bypass capacitors should be placed next to each Vdd pin for best performance.

Capacitors near the microphone should not contain Class 2 dielectrics due to their piezoelectric effect.

Detailed information on acoustic, mechanical, and system integration can be found in the latest *SiSonic™ Design Guide* application note.

Microphone	SELECT	Asserts DATA on	Latch DATA on
Mic (High)	Vdd	CLK rising edge	CLK falling edge
Mic (Low)	Ground	CLK falling edge	CLK rising edge

Table 7: SELECT Functionality

Performance Curves

Test Conditions: V_{dd}=1.8V, F_s = 2.4MHz, no load, unless otherwise indicated

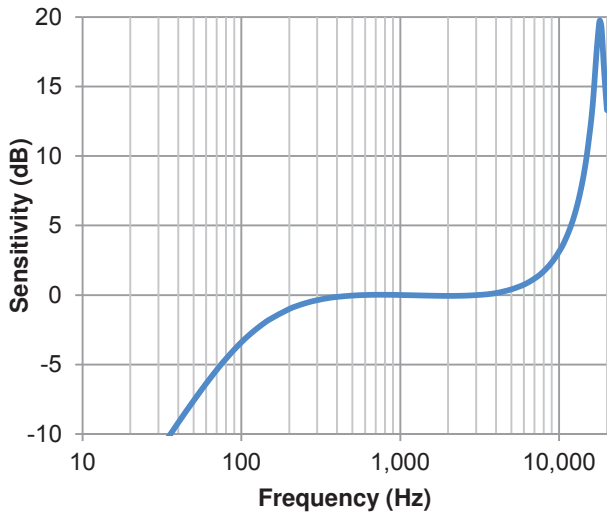

Figure 5: Typical Free Field Response Normalized to 1 kHz

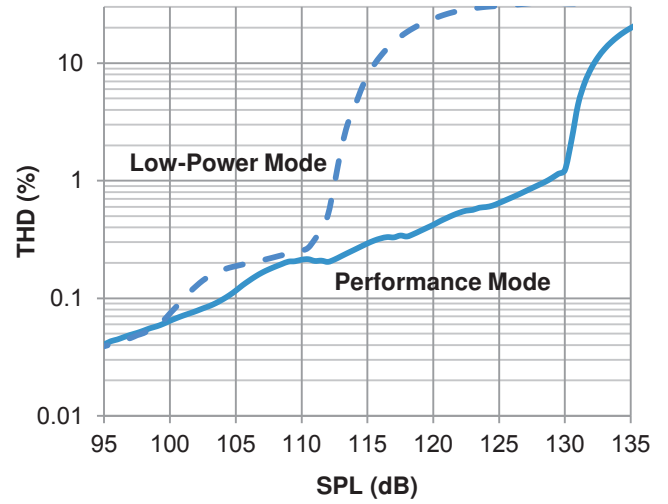

Figure 7: Typical THD vs SPL

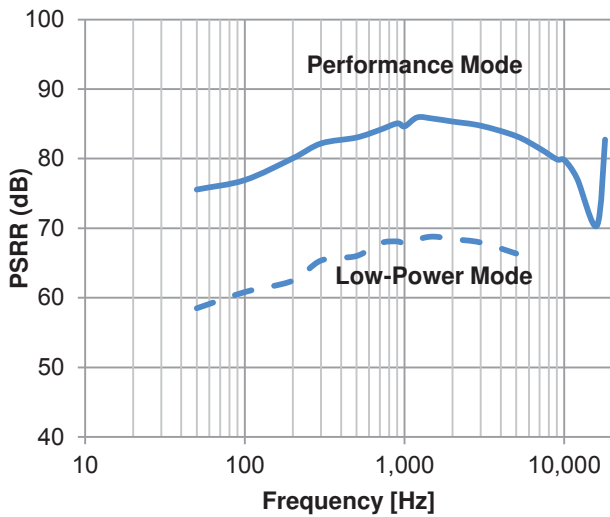

Figure 6: Typical PSRR

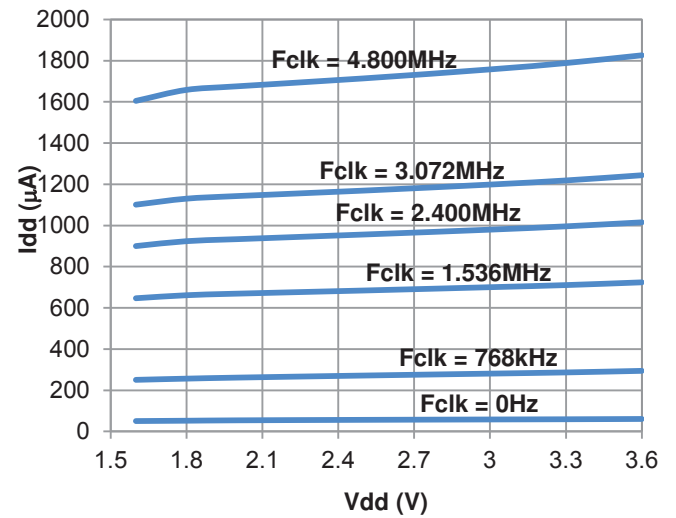
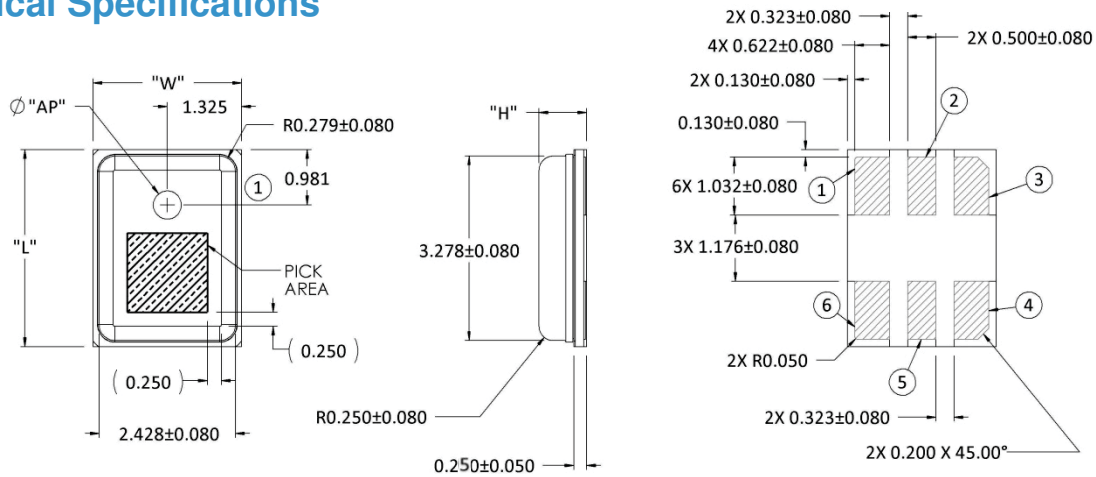

Figure 8: Typical I_{dd} vs V_{dd}

Mechanical Specifications



tem	Dimension	Tolerance
Length (L)	3.50	±0.10
Width (W)	2.65	±0.10
Height (H)	0.85	±0.10
Acoustic Port (AP)	∅0.50	±0.05

Pin #	Pin Name	Type	Description
1	Vdd	Power	Power Supply
2	CLOCK	Digital I	Clock Input
3	DATA	Digital O	PDM Output
4	GROUND	Power	Ground
5	SELECT	Non-Digital Input	Lo/Hi (L/R) Select. This pin is internally pulled low
6	GROUND	Power	Ground

Example Land Pattern

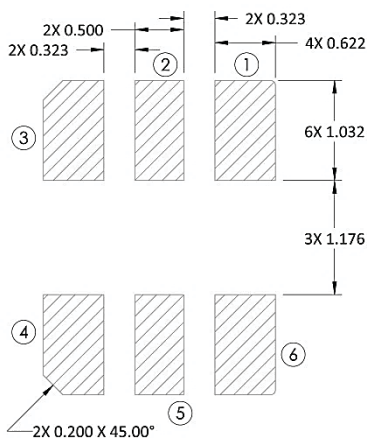

Example Solder Stencil Pattern

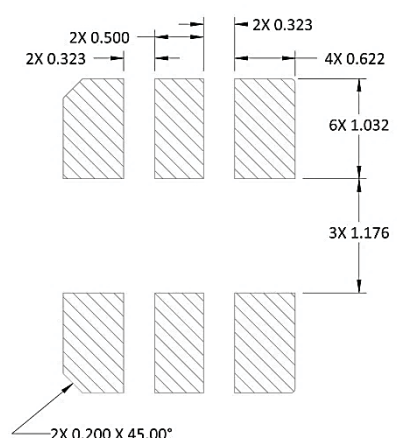

Notes: Pick Area only extends to 0.25 mm of any edge or hole unless otherwise specified.
 Dimensions are in millimeters unless otherwise specified.
 Tolerance is ±0.15mm unless otherwise specified
 Detailed information on AP size considerations can be found in the latest *SiSonic™ Design Guide* application note.
 Further optimizations based on application should be performed.

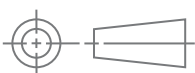

Packaging & Marking Detail

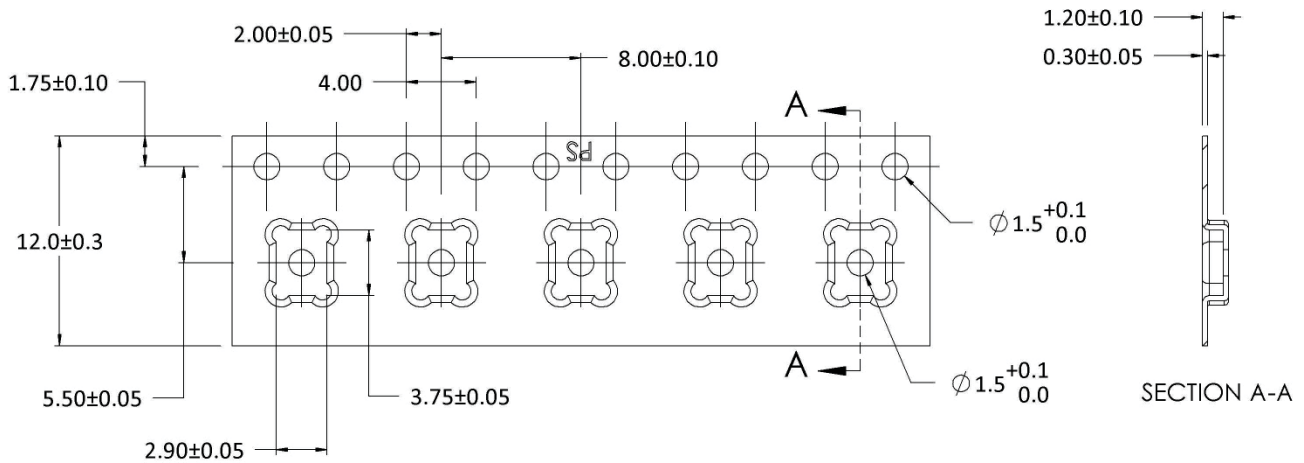

Model Number	Suffix	Reel Diameter	Quantity Per Reel
SPH0644HM4H-1	-8	13"	5,900

Component	Surface Resistance (ohms)
Reel	$10^5 - 10^9$
Carrier Tape	$10^5 - 10^9$
Cover Tape	$10^4 - 10^{10}$

Alpha Character A:

"S": Knowles SiSonic™ Production

"E": Knowles Engineering Samples

"P": Knowles Prototype Samples

Digits 1-8:

Unique Job Identification Number for product traceability

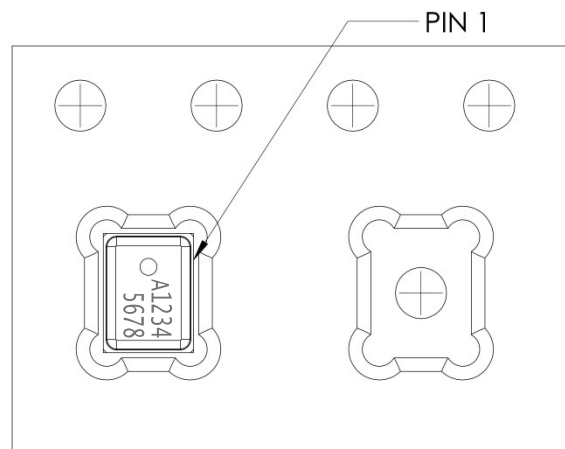

Notes: Dimensions are in millimeters unless otherwise specified.
Vacuum pickup only in the pick area indicated in Mechanical Specifications.
Tape & reel per EIA-481.

Labels applied directly to reel and external package.

Shelf life: Twelve (12) months when devices are to be stored in factory supplied, unopened ESD moisture sensitive bag under maximum environmental conditions of 30°C, 70% R.H.

Recommended Reflow Profile

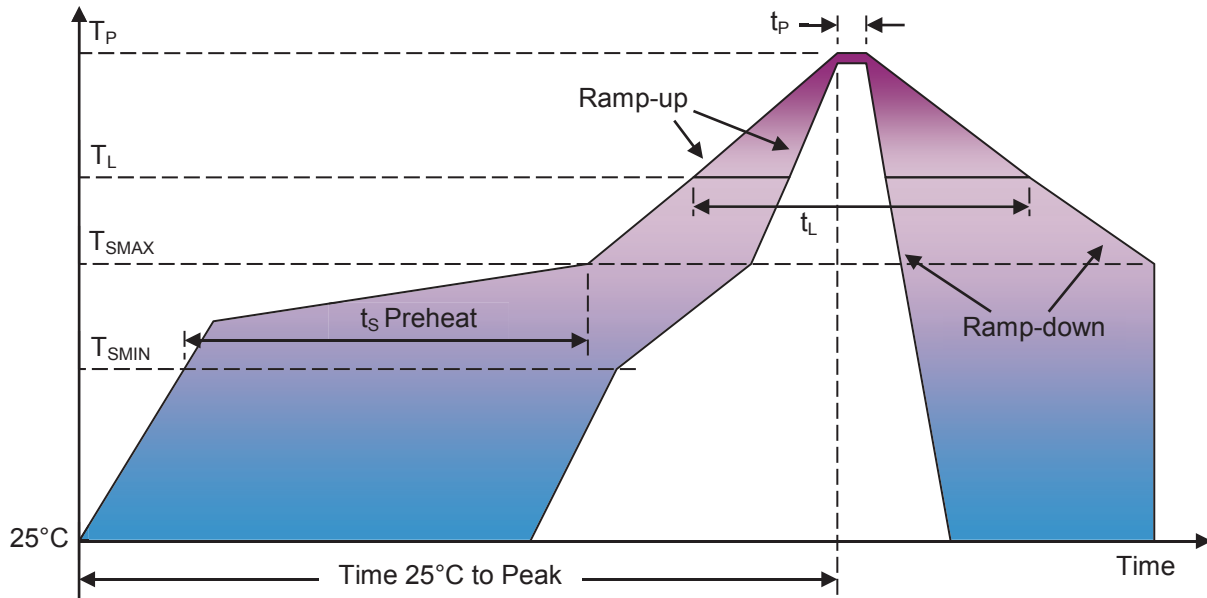

Profile Feature	Pb-Free
Average Ramp-up rate (T_{SMAX} to T_P)	3°C/second max.
Preheat <ul style="list-style-type: none"> Temperature Min (T_{SMIN}) Temperature Max (T_{SMAX}) Time (T_{SMIN} to T_{SMAX}) (t_s) 	150°C 200°C 60-180 seconds
Time maintained above: <ul style="list-style-type: none"> Temperature (T_L) Time (t_L) 	217°C 60-150 seconds
Peak Temperature (T_P)	260°C
Time within 5°C of actual Peak Temperature (t_p)	20-40 seconds
Ramp-down rate (T_P to T_{SMAX})	6°C/second max
Time 25°C to Peak Temperature	8 minutes max

Notes: Based on IPC/JDEC J-STD-020 Revision C.
All temperatures refer to topside of the package, measured on the package body surface

Additional Notes

- (A) MSL (moisture sensitivity level) Class 1.
- (B) Maximum of 3 reflow cycles is recommended.
- (C) In order to minimize device damage:
- Do not board wash or clean after the reflow process.
 - Do not brush board with or without solvents after the reflow process.
 - Do not directly expose to ultrasonic processing, welding, or cleaning.
 - Do not insert any object in port hole of device at any time.
 - Do not apply over 30 psi of air pressure into the port hole.
 - Do not pull a vacuum over port hole of the microphone.
 - Do not apply a vacuum when repacking into sealed bags at a rate faster than 0.5 atm/sec.

Materials Statement

Meets the requirements of the European RoHS directive 2011/65/EC as amended.

Meets the requirements of the industry standard IEC 61249-2-21:2003 for halogenated substances and Knowles Green Materials Standards Policy section on Halogen-Free.

Ozone depleting substances are not used in the product or the processes used to make the product, including compounds listed in Annex A, B, and C of the "Montreal Protocol on Substances That Deplete the Ozone Layer."

Reliability Specifications

Test	Description
Thermal Shock	100 cycles of air-air thermal shock from -40°C to +125°C with 15 minute soaks (IEC 68-2-4)
High Temperature Storage	+105°C environment for 1,000 hours (IEC 68-2-2 Test Ba)
Low Temperature Storage	-40°C environment for 1,000 hours (IEC 68-2-2 Test Aa)
High Temperature Bias	+105°C environment while under bias for 1,000 hours (IEC 68-2-2 Test Ba)
Low Temperature Bias	-40°C environment while under bias for 1,000 hours (IEC 68-2-2 Test Aa)
Temperature/Humidity Bias	+85°C/85% R.H. environment while under bias for 1,000 hours (JESD22-A101A-B)
Vibration	12 minutes in each axis from 20 to 2,000 Hz in X,Y, and Z directions with peak acceleration of 20g (MIL 883E, Method 2007.2,A)
Electrostatic Discharge	3 discharges at +/-8kV direct contact to lid when unit is grounded (IEC 61000-4-2) and 3 discharges at +/-2kV direct contact to I/O pins (MIL 883E, Method 3015.7) and 3 discharges at +/- 200V pin-to-pin (ESDA STM 5.2, ESD-MM)
Reflow	5 reflow cycles with peak temperature of +260°C
Tumble test	200 tumbles in 100g block from a height of 1m onto a steel base
Mechanical Shock	3 pulses of 10,000g in each of the ±X, ±Y, ±Z directions while under bias (IEC 68-2-27 Test Ea)

Notes: After 3 reflow cycles, the sensitivity of the microphones shall not deviate more than 1 dB from its initial value.

Specification Revisions

Revision	Specification Changes	Date
A	Initial Release without correct device photo (ECN 15-542)	12/17/2015
B	Add Vdd-Clock timing and photo, update max Tdd (ECR 16-1005)	7/11/2016

Information contained herein is subject to change without notice. It may be used by a party at their own discretion and risk. We do not guarantee any results or assume any liability in connection with its use. This publication is not to be taken as a license to operate under any existing patents.

Model/Reference Number:

Datasheet SPH0644HM4H-1 Rev B

© Copyright 2016 Knowles

Phone: (630) 250-5100

Fax: (630) 250-0575

sales@knowles.com

Knowles

1151 Maplewood Drive

Itasca, Illinois 60143