



Chipsmall Limited consists of a professional team with an average of over 10 year of expertise in the distribution of electronic components. Based in Hongkong, we have already established firm and mutual-benefit business relationships with customers from,Europe,America and south Asia,supplying obsolete and hard-to-find components to meet their specific needs.

With the principle of “Quality Parts,Customers Priority,Honest Operation,and Considerate Service”,our business mainly focus on the distribution of electronic components. Line cards we deal with include Microchip,ALPS,ROHM,Xilinx,Pulse,ON,Everlight and Freescale. Main products comprise IC,Modules,Potentiometer,IC Socket,Relay,Connector.Our parts cover such applications as commercial,industrial, and automotives areas.

We are looking forward to setting up business relationship with you and hope to provide you with the best service and solution. Let us make a better world for our industry!



## Contact us

Tel: +86-755-8981 8866 Fax: +86-755-8427 6832

Email & Skype: info@chipsmall.com Web: www.chipsmall.com

Address: A1208, Overseas Decoration Building, #122 Zhenhua RD., Futian, Shenzhen, China



# Installation Instructions for the **SMART Position Sensor, 35 mm, 75 mm and 225 mm Linear Configurations**

## **GENERAL INFORMATION**

Why is the SMART Position Sensor smart? SMART means that this is a sensor that can essentially think for itself. The SMART Position Sensor has the ability to self-calibrate because it uses a patented combination of an ASIC (Application-Specific Integrated Circuit) and an array of MR (magneto-resistive) sensors to accurately and reliably determine the position of a magnet attached to a moving object (e.g., elevator, valve, machinery, etc.) so that the object's position can be determined.

The MR array measures the output of the MR sensors mounted along the magnet's direction of travel. The output and the MR sensor sequence determine the nearest pair of MR sensors to the center of the magnet location. The output of these two MR sensors is then used to determine the position of the magnet between them. With this sensor, Honeywell has utilized MR technology through the ASIC at a level never before accomplished.

## **MOUNTING AND WIRING INFORMATION (See Fig. 2.)**

1. Locate sensor and magnet in desired position. Ensure:
  - Air gap between sensor and magnet does not exceed that given in Table 1.
  - Alignment of magnet along length of sensor does not exceed  $2,0 \pm 2,5$  mm [ $0.078 \pm 0.098$  in] from the center line of each component.
2. Mount sensor:
  - Drill two holes, one for each mounting ear.
  - Secure sensor using two ¼-20 or M6 screws through each mounting ear.
  - Torque screws to 6 N m to 10 N m [53.1 in lb to 88.5 in lb].
3. Mount magnet (Does not apply to 35 mm version.):
  - Drill two holes:
    - One for the single mounting ear.
    - One at  $10,25 \pm 0.10$  mm [ $0.403 \pm 0.004$ ] dia., and at least 3 mm [0.118 in] deep, for the mounting dog (helps stabilize magnet).
  - While ensuring the mounting dog is seated in its hole, secure magnet using one ¼-20 or M6 screw through the mounting ear.
  - Torque screws to 6 N m to 10 N m [53.1 in lb to 88.5 in lb].
4. Wire sensor according to the lead colors given in Table 1. (Does not apply to 35 mm version.)

# SMART Position Sensor, 35 mm, 75 mm and 225 mm Linear Configurations

ISSUE 4  
50046793

Table 1. Specifications

| Characteristic                            | Component  | Parameter                          |   |                                     |                            |                     |
|---|--|------------------------------------|---|-------------------------------------|----------------------------|---------------------|
|   |  | 35 mm                              | 75 mm   | 225 mm                              |                            |                     |
|   |  | analog<br>(SPS-L035-LATS)          | analog<br>(SPS-L075-HALS)                         | analog<br>( SPS-L075-HALS)          | digital<br>(SPS-L225-HDLS) |                     |
| Sensing range                             | sensor only  | 0 mm to 35 mm<br>[0 in to 1.38 in] | 0 mm to 75 mm<br>[0 in to 32.95 in]               | 0 mm to 225 mm<br>[0 in to 8.86 in] |                            |                     |
| Resolution                                |  | 0.04 mm [0.0016 in]                | 0,05 mm [0.002 in]                                | 0,14 mm [0.0055 in]                 | 0,0035 mm [0.000137 in]    |                     |
| Supply voltage                            |  | 4.75 Vdc to 5.25 Vdc               | 6 Vdc to 24 Vdc                                   |                                     |                            |                     |
| Output                                    |  | 0.55 Vdc to 4.15 Vdc               | 0 Vdc to 5 Vdc                                    |                                     |                            | RS 232-type digital |
| Supply current                            |  | 20 mA max.                         | 32 mA max.  | 34 mA max.                          | 88 mA max.                 |                     |
| Linearity <sup>1</sup>                    |  | ±1.0% full scale output            | ±0.4% full scale output                           |                                     |                            |                     |
| Reverse polarity                          |  | -5 V                               | 26.4 V at 125 °C [257 °F]                         |                                     |                            |                     |
| Sensitivity                               |  | 103 mV/mm typ.                     | 50 mV/mm typ.                                     | 17.78 mV/mm typ.                    | 282.16 counts/mm typ.      |                     |
| Update rate                               |  | 476 µs                             | 400 µs  |                                     |                            | 3200 µs             |
| Baud rate                                 |  |                                    | -   |                                     |                            | 57.6 kbits/s        |
| Initial startup time                      |  |                                    | 5 ms  | 30 ms                               |                            |                     |
| Termination                               |  |                                    | TYCO Super Seal<br>282087-1<br>integral connector | flying leads                        |                            |                     |
| Cable bend radius                         |  |                                    | -   | 40 mm [1.6 in] min.                 |                            |                     |
| Operating temperature                     |  | sensor and magnet actuator         | -40 °C to 125 °C [-40 °F to 257 °F]               |                                     |                            |                     |
| Storage temperature                       | -40 °C to 150 °C [-40 °F to 302 °F]                      |                                    |   |                                     |                            |                     |
| Air gap                                   | 8,5 ±1,0 mm<br>[0.334 ±0.039 in]                         |                                    | 3,0 ±2,5 mm [0.118 ±0.098 in]                     |                                     |                            |                     |
| Sealing                                   | IP67, IP69K  |                                    |   |                                     |                            |                     |
| Radiated immunity                         | 100 V/m per ISO 11452-2                                  |                                    | -   |                                     |                            |                     |
| Conducted immunity                        | 100 mA BCI per ISO 11452-4                               |                                    | -   |                                     |                            |                     |
| Shock                                     | 50 G half sine wave with 11 ms duration                  |                                    |   |                                     |                            |                     |
| Vibration                                 | 20 G from 10 Hz to 2000 Hz                               |                                    | 10 G from 10 Hz to 2000 Hz                        |                                     |                            |                     |
| Housing material                          | thermoplastic  |                                    |   |                                     |                            |                     |
| Approvals                                 | CE   |                                    |   |                                     |                            |                     |
| Mounting:<br>screws<br>recommended torque | ¼-20 or M6<br>6 N m to 10 N m [53.1 in lb to 88.5 in lb] |                                    |   |                                     |                            |                     |
| Material                                  | magnet ac-<br>tuator only                                |                                    | neodymium iron boron                              |                                     |                            |                     |
| Strength                                  |  |                                    | 13,500 Gauss                                      | 10,000 Gauss                        |                            |                     |

**Note:**

1. Percent linearity is the quotient of the measured output deviation from the best fit line at the measured temperature to the full scale output span.

**NOTICE**

- Ferrous metal within a 100 mm [3.9 in] radius of the magnet actuator may affect sensor performance.
- Always use fresh, non-magnetic stainless steel washers when mounting the sensor.

# SMART Position Sensor, 35 mm, 75 mm and 225 mm Linear Configurations

ISSUE 4  
50046793

Figure 1. SPS-L035-LATS Dimensional Drawing (for reference only: mm) and Sensor Output Performance Graph

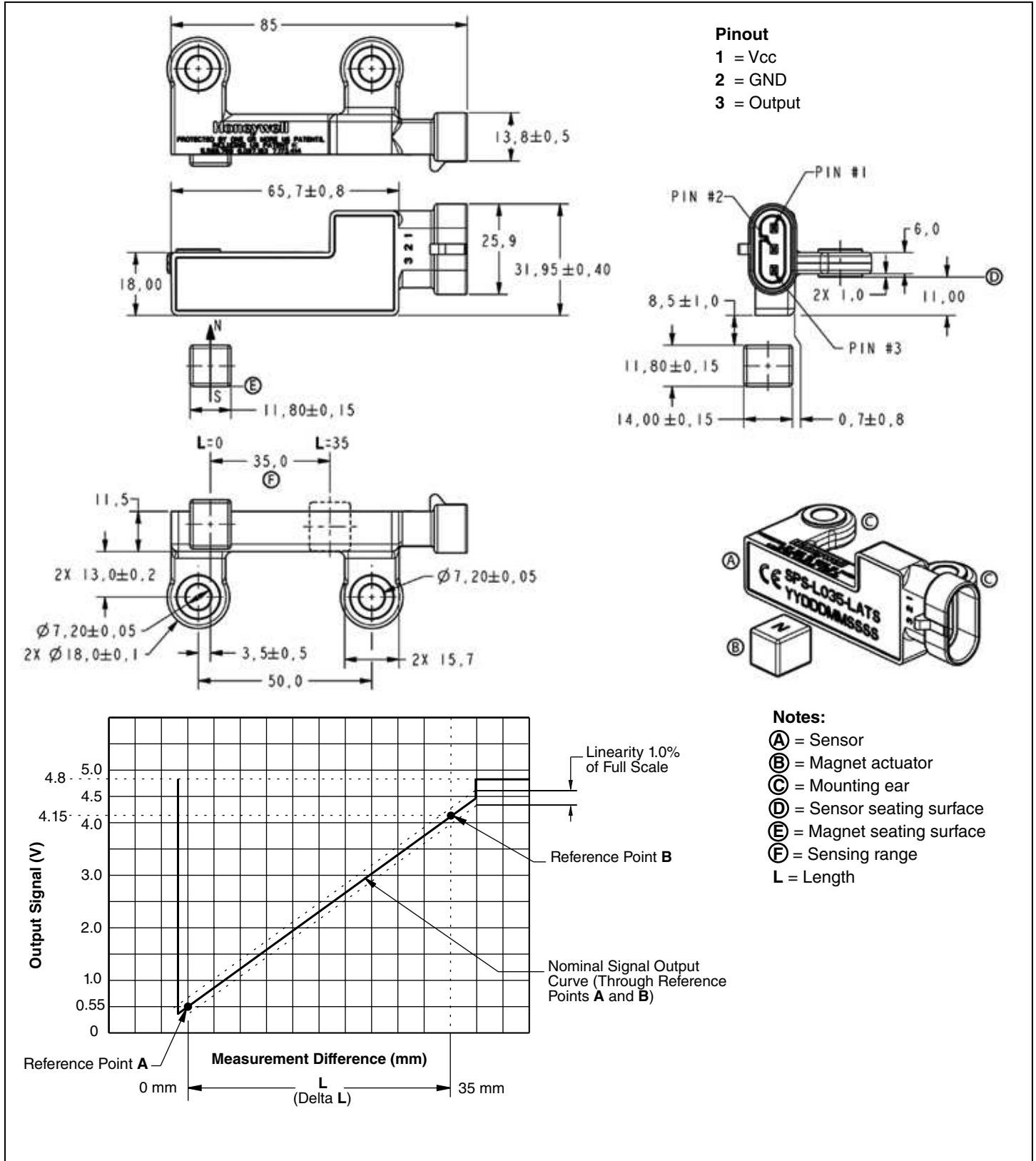

# SMART Position Sensor, 35 mm, 75 mm and 225 mm Linear Configurations

ISSUE 4  
50046793

Figure 2. SPS-L075-HALS Dimensional Drawing (for reference only: mm) and Sensor Output Performance Graph

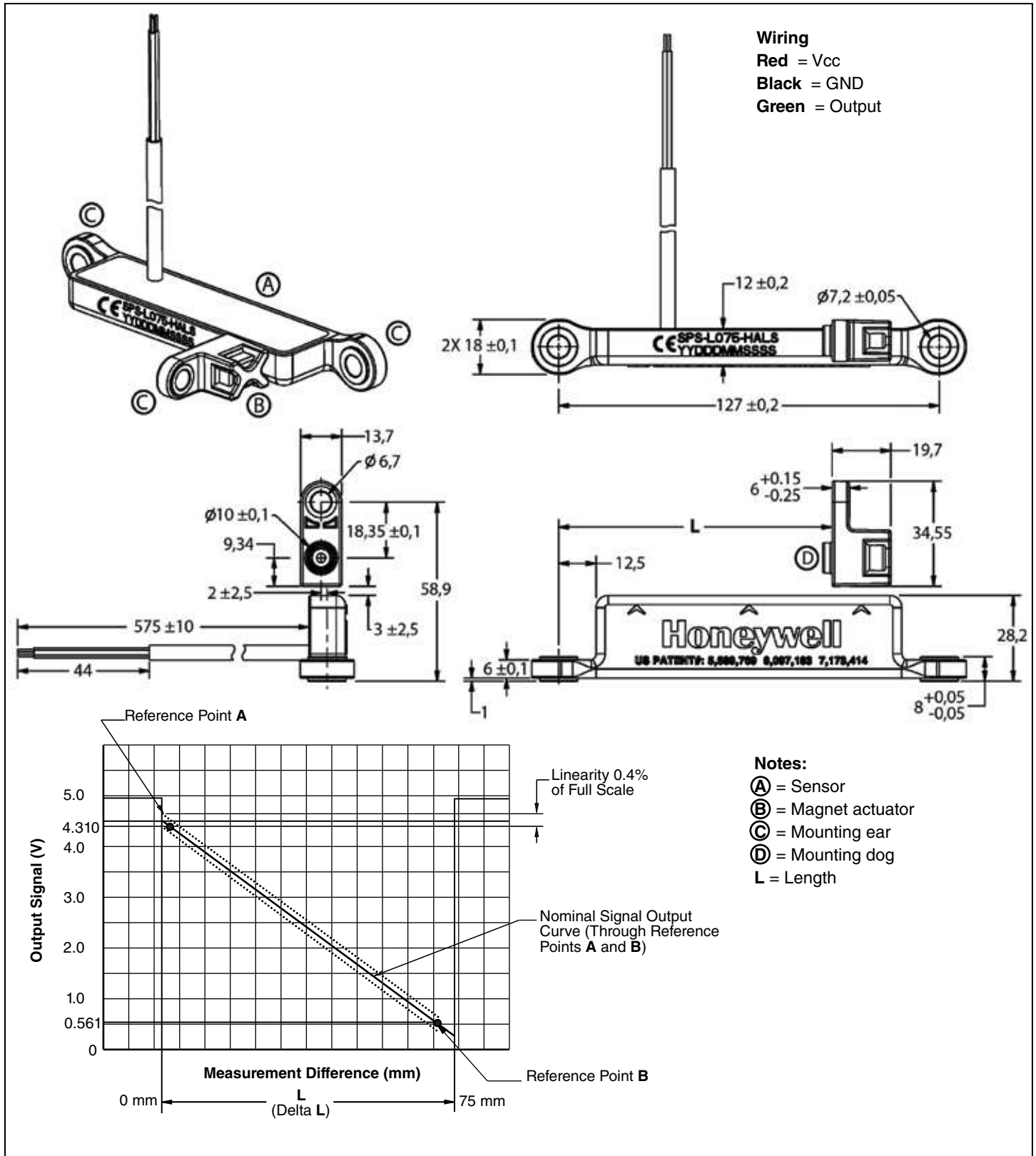

# SMART Position Sensor, 35 mm, 75 mm and 225 mm Linear Configurations

ISSUE 4  
50046793

Figure 3. SPS-L225-HALS Dimensional Drawing (for reference only: mm) and Sensor Output Performance Graph

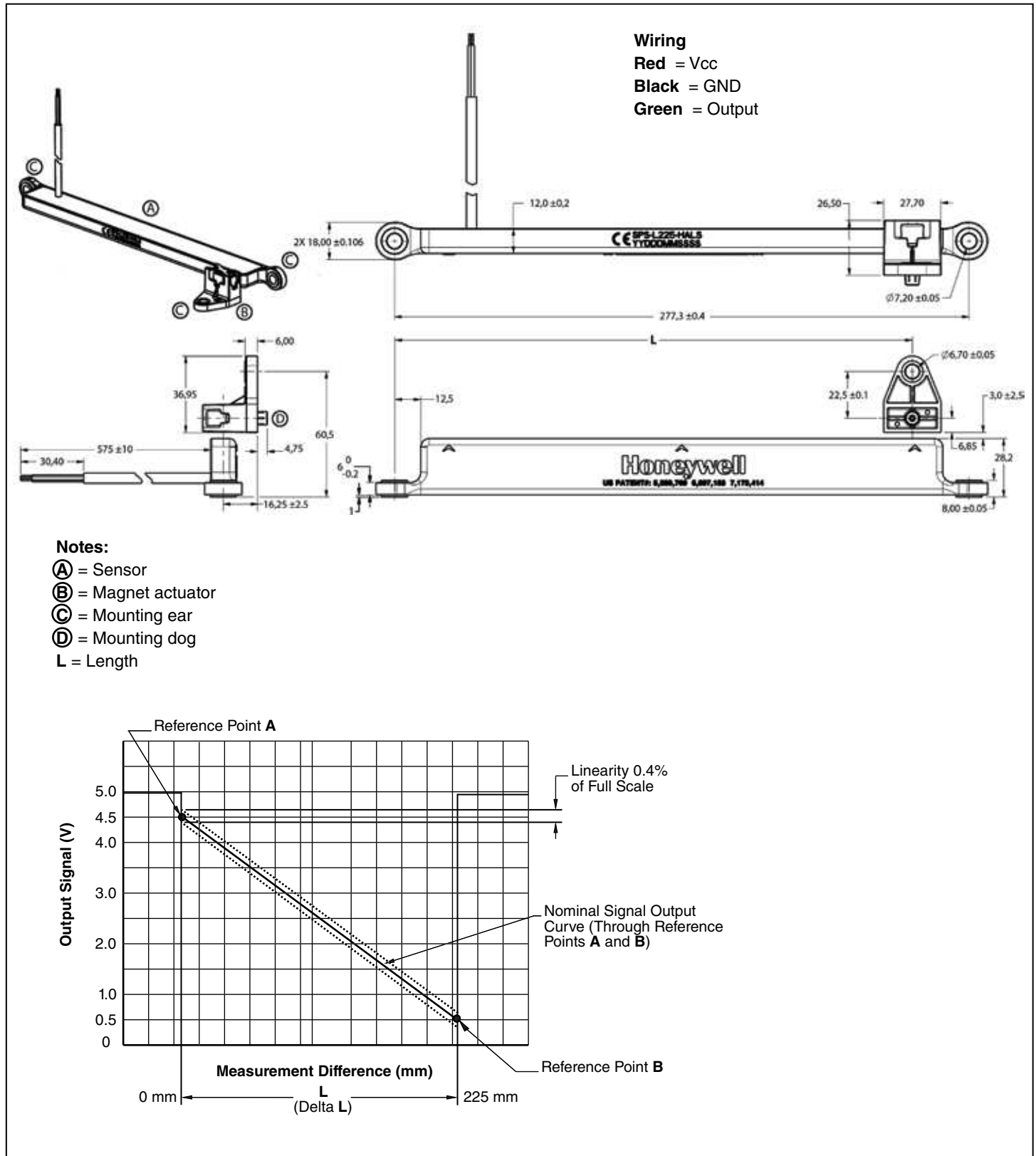

# SMART Position Sensor, 35 mm, 75 mm and 225 mm Linear Configurations

ISSUE 4  
50046793

Figure 4. SPS-L225-HDLS Dimensional Drawing (for reference only: mm) and Sensor Output Performance Graph

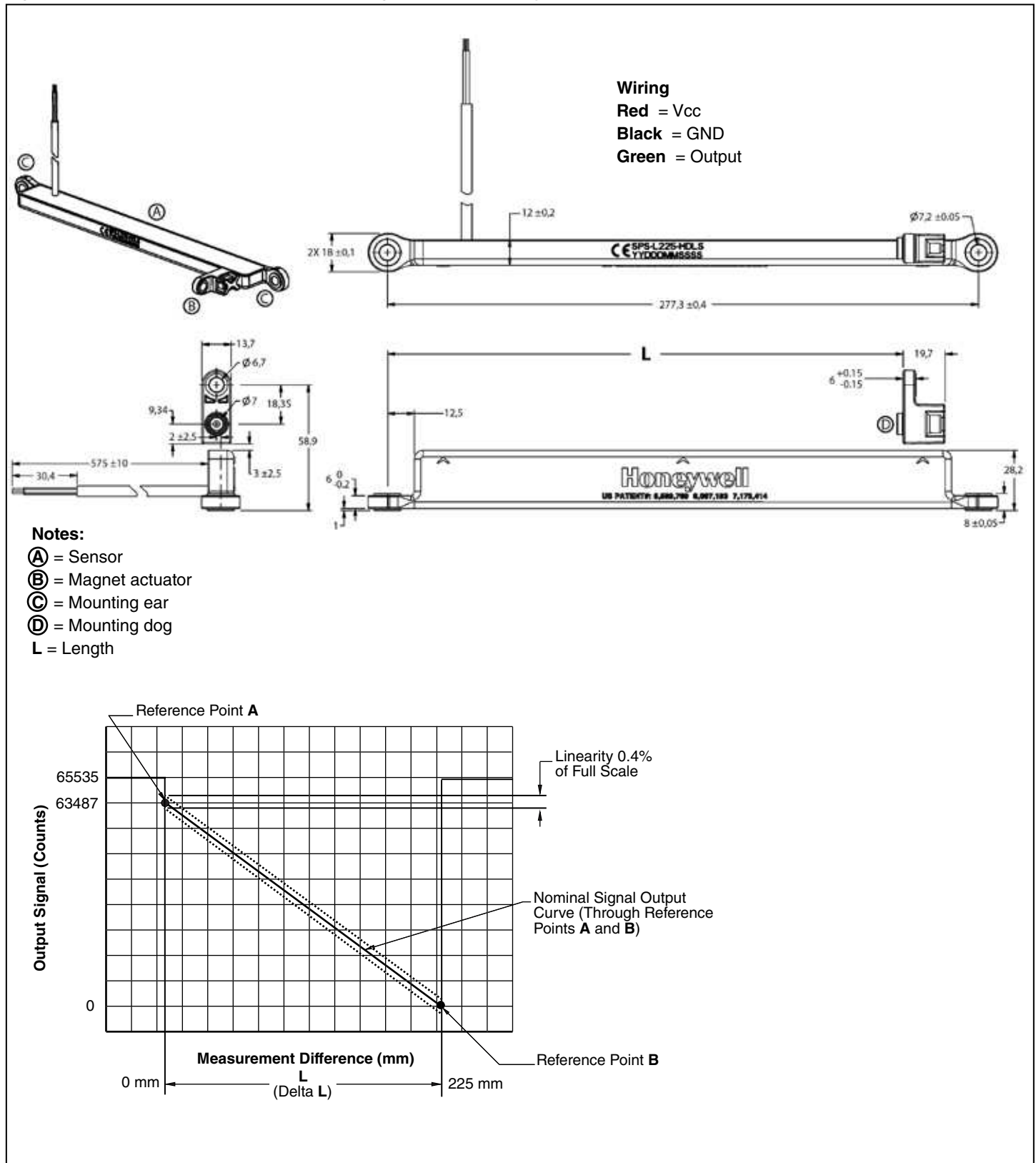

# SMART Position Sensor, 35 mm, 75 mm and 225 mm Linear Configurations

ISSUE 4  
50046793

## WARNING

### PERSONAL INJURY

DO NOT USE these products as safety or emergency stop devices or in any other application where failure of the product could result in personal injury.

**Failure to comply with these instructions could result in death or serious injury.**

### WARRANTY

Honeywell warrants goods of its manufacture as being free of defective materials and faulty workmanship. Honeywell's standard product warranty applies unless agreed to otherwise by Honeywell in writing; please refer to your order acknowledgement or consult your local sales office for specific warranty details. If warranted goods are returned to Honeywell during the period of coverage, Honeywell will repair or replace, at its option, without charge those items it finds defective. **The foregoing is buyer's sole remedy and is in lieu of all warranties, expressed or implied, including those of merchantability and fitness for a particular purpose. In no event shall Honeywell be liable for consequential, special, or indirect damages.**

While we provide application assistance personally, through our literature and the Honeywell web site, it is up to the customer to determine the suitability of the product in the application.

Specifications may change without notice. The information we supply is believed to be accurate and reliable as of this printing. However, we assume no responsibility for its use.

### SALES AND SERVICE

Honeywell serves its customers through a worldwide network of sales offices, representatives and distributors. For application assistance, current specifications, pricing or name of the nearest Authorized Distributor, contact your local sales office or:

E-mail: [info.sc@honeywell.com](mailto:info.sc@honeywell.com)

Internet: [sensing.honeywell.com](http://sensing.honeywell.com)

Phone and Fax:

|               |                         |
|---------------|-------------------------|
| Asia Pacific  | +65 6355-2828           |
|               | +65 6445-3033 Fax       |
| Europe        | +44 (0) 1698 481481     |
|               | +44 (0) 1698 481676 Fax |
| Latin America | +1-305-805-8188         |
|               | +1-305-883-8257 Fax     |
| USA/Canada    | +1-800-537-6945         |
|               | +1-815-235-6847         |
|               | +1-815-235-6545 Fax     |

### Honeywell Sensing and Control

1985 Douglas Drive North  
Golden Valley, MN 55422  
[sensing.honeywell.com](http://sensing.honeywell.com)

50046793-4-EN  
August 2013  
© 2013 Honeywell International Inc. All rights reserved.

# Honeywell