



Chipsmall Limited consists of a professional team with an average of over 10 year of expertise in the distribution of electronic components. Based in Hongkong, we have already established firm and mutual-benefit business relationships with customers from,Europe,America and south Asia,supplying obsolete and hard-to-find components to meet their specific needs.

With the principle of “Quality Parts,Customers Priority,Honest Operation,and Considerate Service”,our business mainly focus on the distribution of electronic components. Line cards we deal with include Microchip,ALPS,ROHM,Xilinx,Pulse,ON,Everlight and Freescale. Main products comprise IC,Modules,Potentiometer,IC Socket,Relay,Connector.Our parts cover such applications as commercial,industrial, and automotives areas.

We are looking forward to setting up business relationship with you and hope to provide you with the best service and solution. Let us make a better world for our industry!



Contact us

Tel: +86-755-8981 8866 Fax: +86-755-8427 6832

Email & Skype: info@chipsmall.com Web: www.chipsmall.com

Address: A1208, Overseas Decoration Building, #122 Zhenhua RD., Futian, Shenzhen, China



Application Note

SiSonic Design Guide

Rev 3.0

Application Note

Table of Contents

1.0 MEMS MICROPHONE TECHNOLOGY	3
2.0 CHOOSING THE RIGHT SISONIC MICROPHONE.....	3
2.1 PACKAGE TYPE.....	3
2.2 OUTPUT FORMAT	7
2.3 RF PROTECTION LEVEL	10
2.4 SISONIC PRODUCT MATRIX	12
3.0 MECHANICAL DESIGN CONSIDERATIONS	14
3.1 CHOOSING THE MIC AND PORT HOLE LOCATIONS	14
3.2 ACOUSTIC PATH DESIGN	14
3.3 WIDEBAND FREQUENCY RESPONSE.....	18
3.4 ECHO AND NOISE PROBLEMS	19
3.5 PCB LAND PATTERN AND SOLDER STENCIL PATTERN	20
4.0 ELECTRICAL DESIGN CONSIDERATIONS	21
4.1 POWER SUPPLY.....	21
4.2 GROUND	21
4.3 GAIN CONTROL.....	21
4.4 MICROPHONE TO CODEC INTERFACE CIRCUIT	22
4.5 SISONIC 2-WIRE CIRCUIT	23
4.6 MINIMIZING NOISE PICK-UP.....	24
5.0 MANUFACTURING INFORMATION.....	26
5.1 PICK-AND-PLACE SETTINGS.....	26
5.2 REWORK	28
5.3 HANDLING AND STORAGE	28
5.4 QUALIFICATION TESTING.....	28
5.5 SENSITIVITY MEASUREMENTS	30
6.0 ADDITIONAL RESOURCES	30

Application Note

1.0 MEMS MICROPHONE TECHNOLOGY

SiSonic MEMS microphones are on the cutting edge of acoustic technology and have gained wide acceptance in many consumer electronics products including smart phones, feature phones, entry phones, laptops, tablet PCs, netbooks, PDAs, and DSCs. The principle of operation for SiSonic microphones is similar to that for traditional Electret Condenser Microphones (ECMs), but since MEMS microphones are manufactured using silicon wafer processes they have smaller form factors, improved performance in varied environmental conditions, and improved ease-of-use in designs.

Purpose: This application note explains the package types, output formats, and RF protection levels available in SiSonic microphones. It also provides information on mechanical design, electrical design, and on using SiSonic microphones in a mass production environment.

2.0 CHOOSING THE RIGHT SISONIC MICROPHONE

SiSonic microphone models vary by **package type, output format, and RF protection level**. The choice of package is driven by the mechanical requirements of the design, the output format by the interface chipset and the application, and the RF protection level by the proximity to antennas and other RF noise sources. The information in this section will help you choose the right SiSonic microphone for your application.

2.1 PACKAGE TYPE

2.1.1 Top-port and Bottom-port SiSonic

Diagrams of the basic construction of SiSonic microphones and port-hole locations are shown in the figures below.

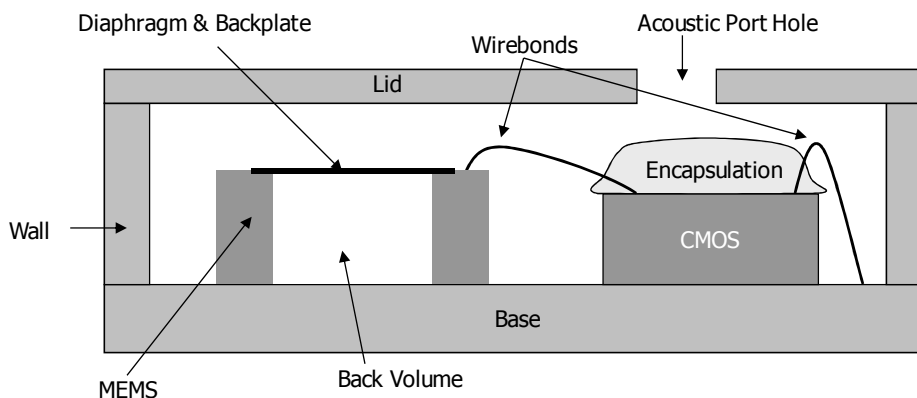

Figure 1: The construction of a top-port SiSonic microphone

Application Note

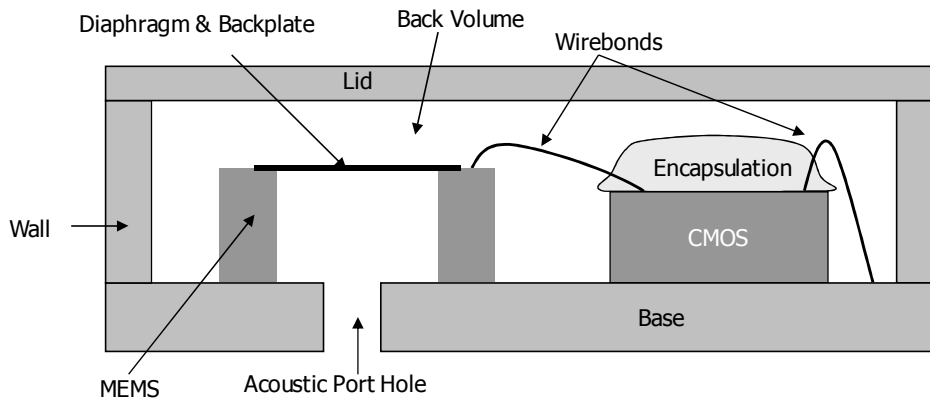

Figure 2: The construction of a bottom-port Zero-Height SiSonic microphone

Top-port SiSonic microphones allow for traditional microphone placement and gasket design, while bottom-port Zero-Height SiSonic microphones are particularly suited for ‘thin’ product designs. Having both package choices gives designers more options for microphone placement within the design constraints. The diagrams below show typical acoustic path mechanical designs when using top-port and bottom-port microphones, along with typical frequency responses for each package.

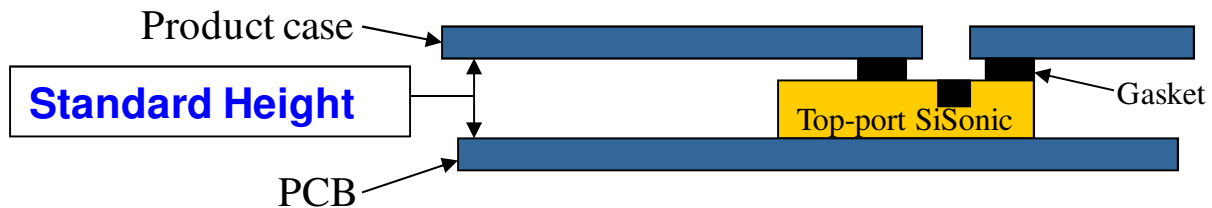

Figure 3: Typical acoustic path design using a top-port SiSonic microphone

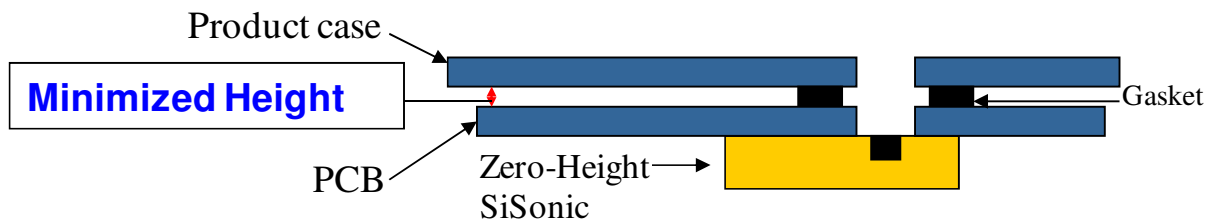

Figure 4: Typical acoustic path design using a bottom-port Zero-Height SiSonic microphone

Application Note

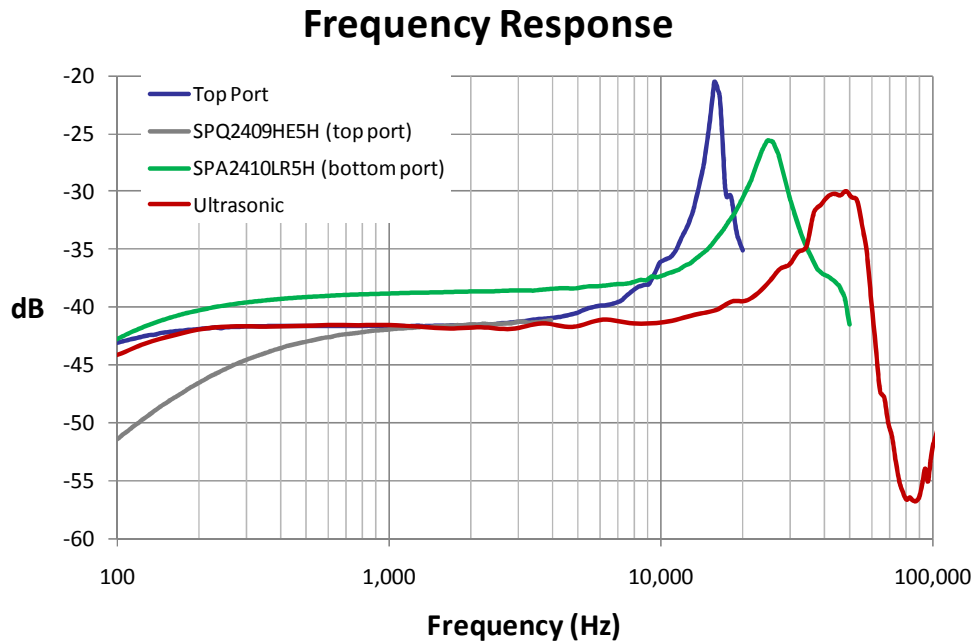

Figure 5: Comparison of the frequency response of main SiSonic package types

2.1.2 Mesh Lid for Ultrasonic Applications

Ultrasonic SiSonic microphones have an open mesh lid design that uses an acoustically transparent mesh as show in the picture below.

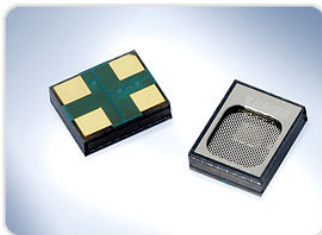

Figure 6: Mesh lid construction of ultrasonic mic

The open lid and mesh allow ultrasonic frequencies from 20 kHz to 80 kHz or more to be captured by the MEMS. The frequency response of ultrasonic Sisonic is shown below.

Application Note

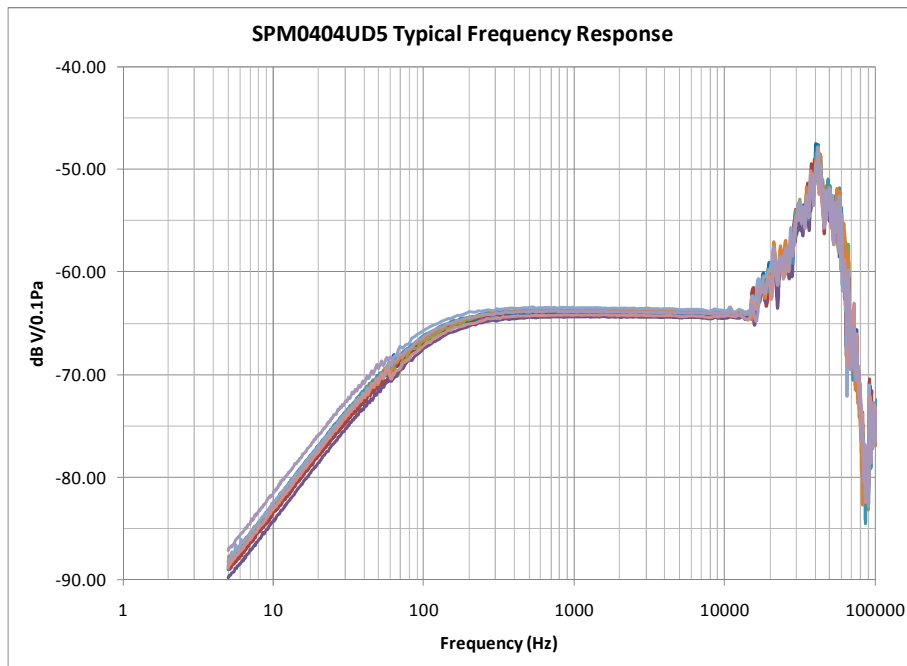

Figure 7: Ultrasonic SiSonic Frequency Response

The output of the ultrasonic SiSonic microphone must be processed by an amplifier, codec, or A/D converter that can extract the ultrasonic frequencies needed by the application, usually by using a higher sample rate and/or lower decimation rate. Ultrasonic SiSonic is ideally suited for applications with natural ultrasonic emissions, or for those requiring a separate transmitter and receiver or multiple transmitters at different frequencies. Potential applications include:

- Consumer Products
 - Ultrasonic pen
 - Gesture recognition
- Automotive Sensors:
 - Parking assistant, curb detection
 - Passenger detection (within cabin)
 - Forward sensing of obstacles
- Industrial Applications
 - Equipment monitoring (mechanical attrition of ball-bearing)
 - Position sensors (for plant use)
 - Gas tube or pipe monitoring (flow or leaks)
 - Security systems (motion detection)
- Military
 - Impulse detection (gunshot detection)
 - Fire-arm positioning sensor

Application Note

2.1.3 Package Size

The microphone footprint decides the minimum PCB area required by the mic, and the mic height sets the minimum vertical space required to integrate the mic into the final product. Dimensions of each SiSonic package are shown in the table and figure below.

Package name	Port-hole location	Representative Model numbers	Length (mm)	Width (mm)	Height (mm)	Footprint (mm ²)
Mini	Top	SPM0410HR5H	4.72	3.76	1.25	17.7
	Bottom (Zero-Height)	SPM0410LR5H			1.40	
	Mesh Top (Ultrasonic)	SPM0404UD5				
SPK	Bottom (Zero-Height)	SPK0413LM4H	4.00	3.00	1.00	12.0
Ultra Mini	Top	SPU0409HD5H SPU0410HR5H	3.76	2.95	0.90	11.1
	Bottom (Zero-Height)	SPU0410LR5H			1.10	
SPQ	Top	SPQ2410HR5H	3.76	2.24	1.10	8.4
SPA	Bottom (Zero-Height)	SPA2410LR5H	3.35	2.50	0.98	8.4
SPY	Bottom (Zero-Height)	SPY0824LR5H	3.00	1.90	0.90	5.7

Table 1: SiSonic Packages, Port-Hole Locations, and Dimensions

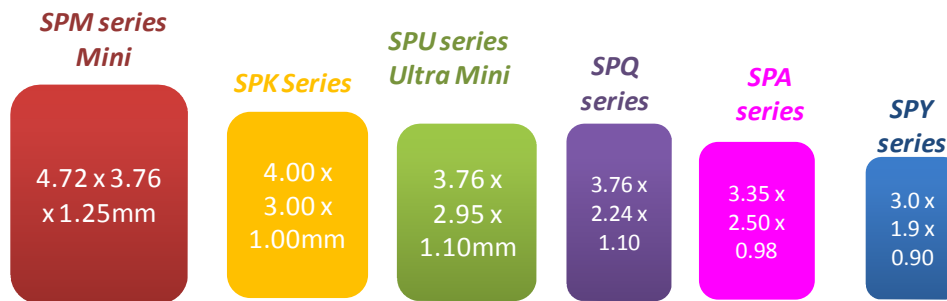

Figure 8: Comparison of SiSonic Package Sizes

2.2 OUTPUT FORMAT

2.2.1 Unity-gain Analog and Amplified Outputs

Unity-gain SiSonic has a simple buffered output as shown in the figure below. A coupling capacitor on the output is required to pass acoustic frequencies to the chipset input while isolating the DC voltages. The coupling capacitor forms a high pass filter with the input resistance of the next stage, and is typically 0.1µF or larger to give a corner frequency below 100Hz.

Application Note

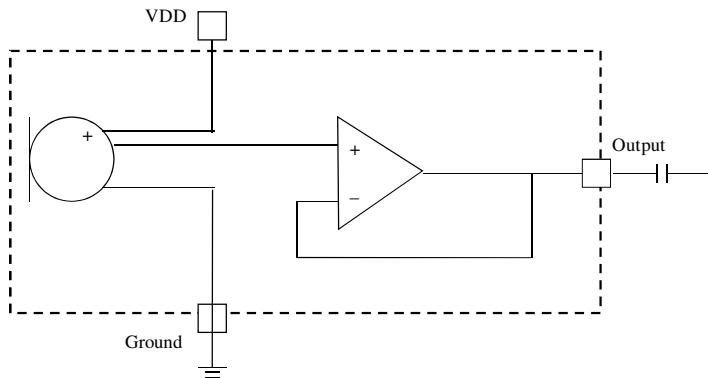

Figure 9: Unity-gain SiSonic Block Diagram

In far-field applications like teleconferencing and video recording, the desired acoustic signal is in the mic far-field and may require additional amplification. Amplified SiSonic microphones add up to 20dB of gain to the analog output signal before transmitting it to the chipset or audio codec. Amplifying the signal at the mic versus at the codec improves the overall system Signal-to-Noise Ratio (SNR) by increasing the transmitted signal size relative to noise in the traces. The amplification in the mic and codec must be chosen appropriately so that the acoustic signal does not saturate either mic or codec during operation.

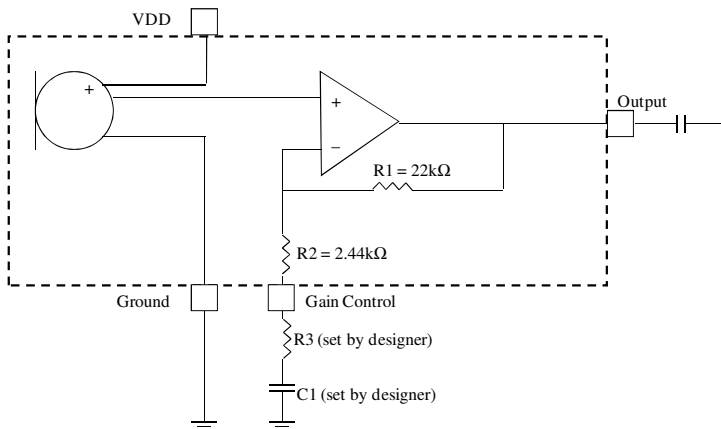

Figure 10: Amplified SiSonic Block Diagram

2.2.2 Differential SiSonic

SiSonic is also available with a differential output driver that offers stronger noise immunity than a single-ended output due to the common mode rejection of noise picked up in traces. Differential SiSonic includes an integrated amplifier that provides up to 14dB of additional amplification. The figure below illustrates a typical differential circuit configuration.

Application Note

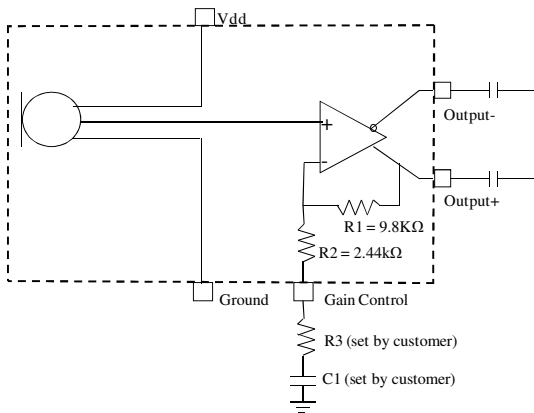

Figure 11: Block Diagram of Differential SiSonic with Amplified Output

2.2.3 Low Frequency SiSonic

Low frequency SiSonic is for applications such as music recording and automotive sensing where low frequency audio signals are being captured. Low frequency SiSonic comes in an Ultra Mini Zero-Height package, and has a low-frequency roll-off at about 5 Hz as shown below.

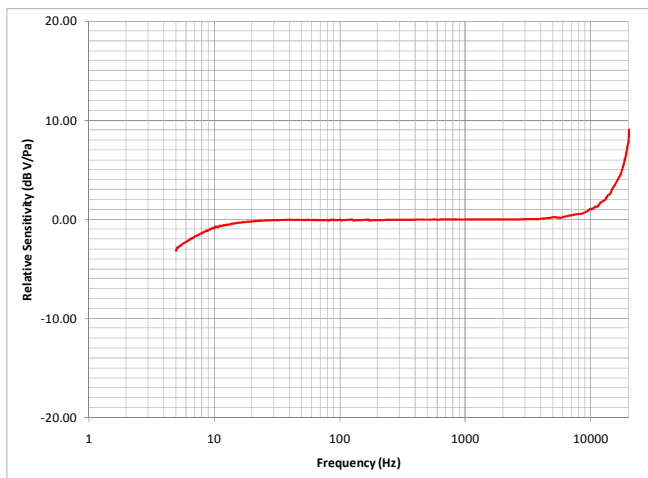

Figure 12: Low Frequency SiSonic Frequency Response Curve

2.2.4 PDM Digital SiSonic

Pulse Density Modulated (PDM) Digital SiSonic microphones have a Sigma-Delta Analog to Digital Converter (ADC) integrated into the microphone that accepts a 1.0 MHz to 3.25 MHz clock, and returns over-sampled PDM data at the supplied clock frequency. Decimation and filtering performed by the receiving chipset convert the PDM data stream into the PCM data for use by application software. The primary advantage of the digital interface is noise immunity, with secondary benefits of reduced overall system power consumption. Because the mic output is a relatively large digital signal, only extreme noise can cause a bit change, and the half-cycle

Application Note

PDM format used makes the audio data relatively immune to even multi-bit errors. Digital SiSonic microphones are ideal for designs requiring relatively long mic signal traces, especially designs using multiple microphones. Mic traces can be routed to virtually any part of the design with few constraints on routing and a higher probability of success with the first layout, at the same time requiring fewer protective components.

The L/R select signal configures the microphone to drive the data line after either the rising edge (Data_H) or falling edge (Data_L) of the clock. A Data_H and Data_L microphone can multiplex data over the same output trace for multi-mic applications, reducing the interface pin count. A basic block diagram of a Digital SiSonic design is shown in Figure 7.

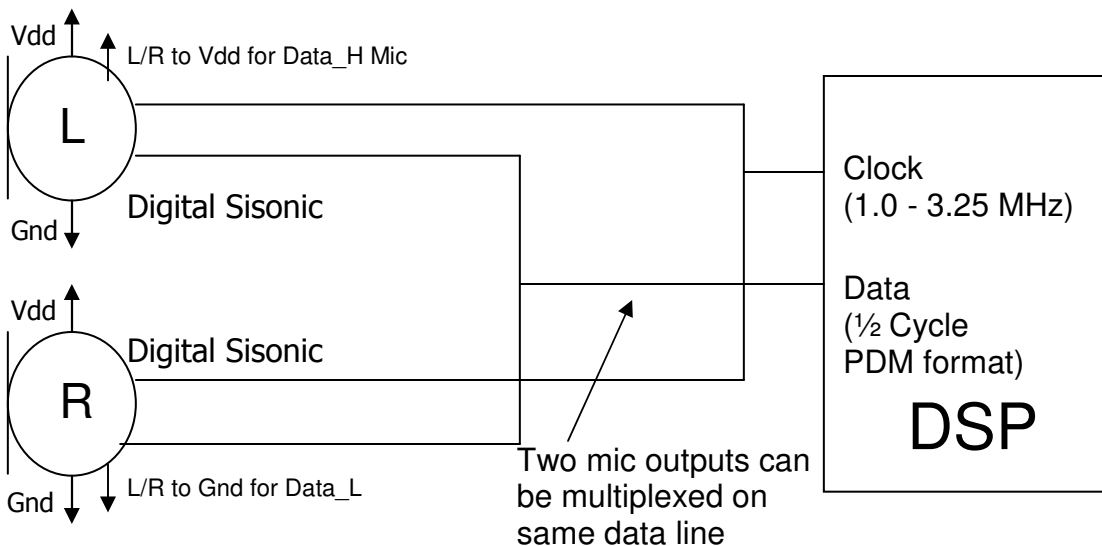

Figure 13: PDM Digital SiSonic Interface

Digital SiSonic microphones require a chipset with a PDM audio interface. Contact Knowles for more information on Digital SiSonic microphones and validated chipset vendors.

2.3 RF PROTECTION LEVEL

SiSonic microphones have integrated RF protection to help prevent RF noise from getting into the acoustic signal. Standard SiSonic microphones have a grounded Faraday cage integrated into the mic package, while Enhanced RF SiSonic microphones also have RC filters built into the base PCB of the microphone. MaxRF SiSonic have the best RF performance, from a soldered metal can package and RF filtering built into both the CMOS and the package of the microphone. The figures below show conceptually how both radiated RF noise and conducted RF noise are shorted to ground in RF-protected SiSonic mics.

Application Note

2.3.1 Standard and Enhanced RF SiSonic

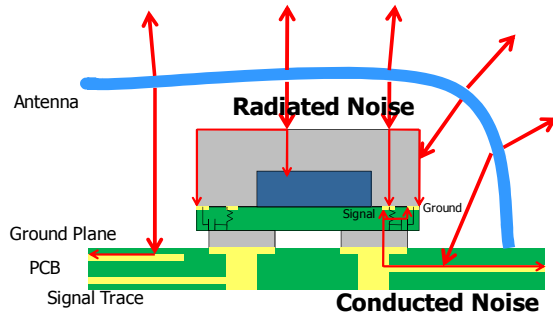

Figure 14: Enhanced RF SiSonic with FR4 package and filtering in the mic base

2.3.1 MaxRF SiSonic

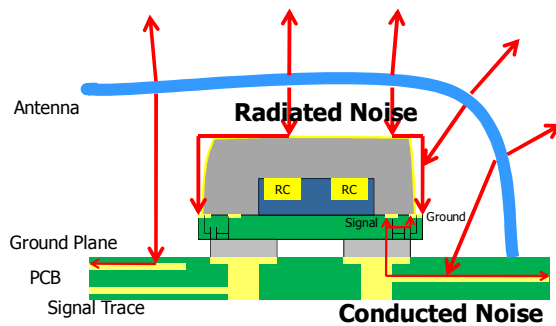

Figure 15: MaxRF SiSonic with metal can package and additional filtering in the CMOS chip

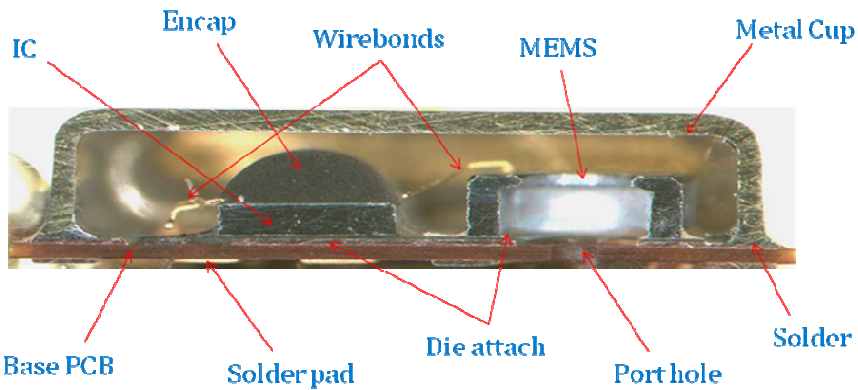

Figure 16: Cross-section a metal can package

Application Note

2.4 SISONIC PRODUCT MATRIX

The table below summarizes the design needs, features, packages, and applications for the various SiSonic models.

Design Requirement	Mini	Mini Zero-Height	SPK Zero-Height	Ultra Mini	Ultra Mini Zero-Height	SPQ	SPA, SPY Zero-Height	Benefit/application
SMD reflow	X	X	X	X	X	X	X	Mounted in standard lead-free solder reflow processes
Thin design		X	X		X		X	Bottom-mount design allows “zero” height requirements on top side of PCB
Small footprint			X			X	X	Minimal use of board space
Amplified output	X	X		X				Far-field applications, improved system SNR
Differential output	X							Better noise immunity from balanced design
Max RF Protection	X	X		X	X	X	X	Best RF noise immunity
Wind Noise Filtering						X	X	Higher low-frequency roll-off reduces wind noise.
Digital PDM interface	X		X					Best noise immunity, no analog circuits in chipset, ideal for multi-mic designs

Table 2: Summary of Design Needs met by SiSonic

Application Note

Package name	Port-hole location	Output Format	RF Protection	Representative Model numbers
Mini	Top	Non-amplified (analog)	Standard	SPM0404HD5H
			Enhanced	SPM0404HE5H
			Maximum	SPM0410HR5H
		Amplified (analog)	Standard	SPM0408HD5H
			Enhanced	SPM0408HE5H
			Enhanced	SPM0406HE3H
	Digital PDM	Standard	SPM0423HD4H	
		Enhanced	SPM0423HM4H	
	Bottom (Zero-Height)	Non-amplified (analog)	Enhanced	SPM0404LE5H
			Maximum	SPM0410LR5H
Amplified (analog)		Enhanced	SPM0408LE5H	
Mesh Top	Ultrasonic (analog)	Standard	SPM0404UD5	
SPK	Bottom (Zero-Height)	Digital PDM	Enhanced	SPK0813LM4H
Ultra Mini	Top	Non-amplified (analog)	Standard	SPU0409HD5H
			Enhanced	SPUL409HE5H
			Maximum	SPU0410HR5H
	Bottom (Zero-Height)	Amplified (analog)	Maximum	SPU0414HR5H
			Non-amplified (analog)	Enhanced
		Low Frequency	Maximum	SPU0410LR5H
SPQ	Top	Non-amplified (analog)	Maximum	SPQ2410HR5H
SPA	Bottom (Zero-Height)	Non-amplified (analog)	Maximum	SPA2410LR5H
SPY	Bottom (Zero-Height)	Non-amplified (analog)	Maximum	SPY0824LR5H

Table 3: A Summary of Available SiSonic Models. (Please contact Knowles for the latest information.)

Application Note

3.0 MECHANICAL DESIGN CONSIDERATIONS

The purpose of this section is to provide mechanical design information relating to the microphone including:

- Choosing locations for the mic(s) and acoustic port hole(s) in the case
- Designing the acoustic path, including gasket design and assembly considerations
- Designing for a wideband frequency response
- Echo prevention and troubleshooting
- Optimizing the land pattern, solder stencil design, and soldering process

3.1 CHOOSING THE MIC AND PORT HOLE LOCATIONS

Choosing a location for the microphone in a design can be challenging. For analog mics in particular, the traces from mic to chipset should be kept as short as possible and as far as possible from potential noise sources. However, the layout of many mobile product designs require that the mic and traces be near antennas, power amplifiers, motors, hard disk drives, switching power supplies, etc. The design engineer must also consider the available board space, component height restrictions, port-hole location(s), acoustic path dimensions, and gasket size, location, and ease-of-assembly in mass production when choosing a mic location.

The external acoustic port hole in the product housing should be located near the mic to simplify the gasket and associated mechanical design. The port-hole must also be far enough from speakers and other acoustic noise sources to minimize the strength of these unwanted signals at the microphone input. In near-field use modes like talk mode in a mobile phone, the port-hole location is more critical than in far-field modes since small changes in distance can change the strength of the acoustic signal arriving at the microphone. In both types of applications, the port hole should be located where it won't be blocked during normal use.

If there are multiple mics in a design, then the mic and port-hole locations are further constrained by the related product use-modes and any audio algorithm requirements. Picking good locations for the microphones and port holes early in the design process can prevent costly PCB layout or plastics changes late in the product design cycle.

3.2 ACOUSTIC PATH DESIGN

The acoustic path guides external sound into the microphone. The overall frequency response of the microphone in the product design is determined by the standalone microphone frequency response and the physical dimensions of each part of the acoustic path, including the case port-hole, gasket(s), and PCB port-hole. The acoustic path must not have leaks that can cause echo or noise problems, and needs to be designed for manufacturability.

Application Note

3.2.1 Acoustic Path Dimensions

A short, wide acoustic path has minimal effects on the mic response while a long, narrow path can create peaks in the audio band, potentially causing a “tinny” sound as higher frequencies are amplified. A good acoustic path design gives a flat sensitivity frequency response across the target acoustic frequency range. The designer must measure the frequency response of the microphone with its acoustic path and make adjustments if the performance doesn’t meet design goals. Possible changes include:

1. A larger case port hole
2. A thinner case at the case port hole
3. A wider gasket cavity
4. A shorter acoustic path from changing the mic or case port hole location
5. A larger and/or thinner PCB hole (for bottom-port mic designs)
6. Adding a screen or mesh as an acoustic resistance to extend the flat frequency response range (see section 3.3)

The codec or baseband chipset that processes the audio signal from the mic generally includes a low-pass filter with a cutoff frequency just above the desired acoustic range to remove the unwanted higher frequency components. The frequency response curves below compare the sensitivity of a standalone microphone, a microphone with a short, wide acoustic path design (gasket A), a microphone with a long, narrow acoustic path design (gasket B), and both gaskets with a 6 kHz filter representative of a typical low-pass digital filter.

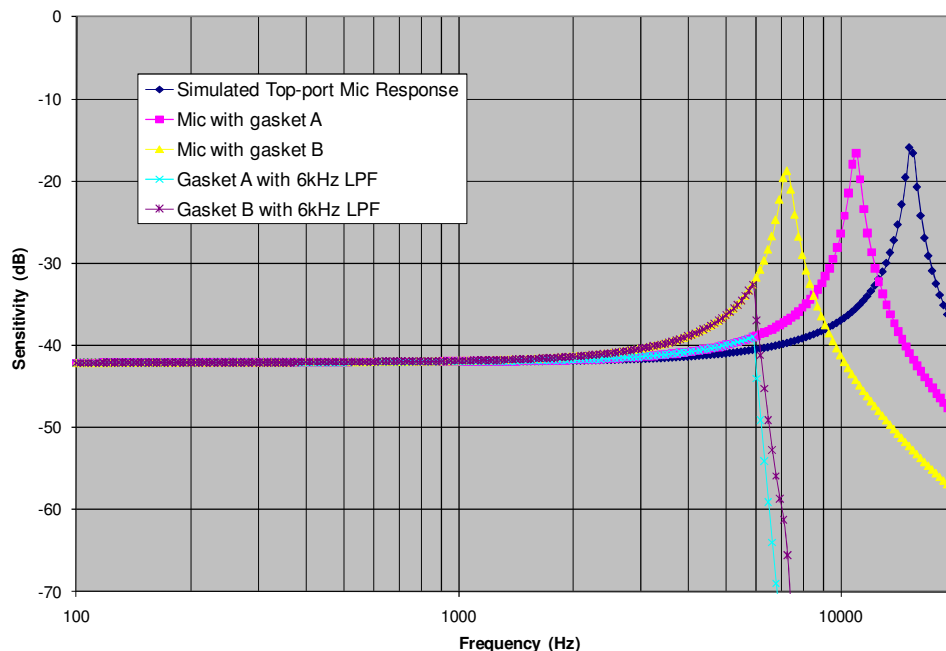

Figure 17: The Effect of Acoustic Path Design on Microphone Frequency Response

Application Note

The gasket should provide a short, wide acoustic path from the port hole in the case to the microphone. For designs using top-port SiSonic microphones, the gasket port-hole should have at least a 0.5mm larger diameter than the microphone port hole to allow for x-y tolerances in the gasket port-hole, mic port-hole, and gasket placement. At the same time, the gasket port-hole must be small enough to ensure a complete seal of the gasket to the mic since any leaks could cause echo, noise, or frequency response problems. A simple acoustic path design for a top-port SiSonic microphone is shown below.

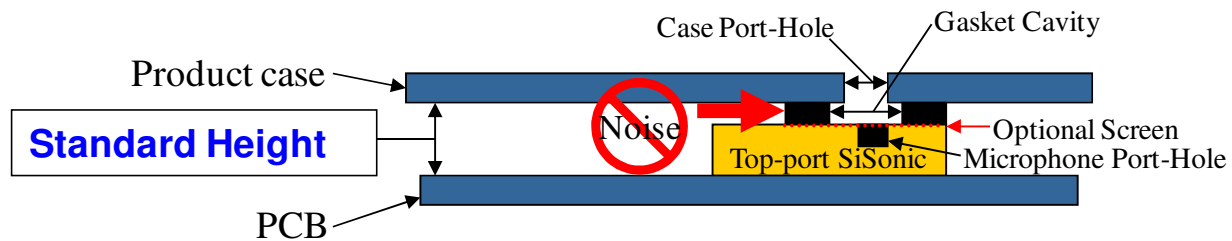

Figure 18: A Simple, Effective Acoustic Path Design for a Top-Port Microphone

For designs using Zero-Height SiSonic microphones, the acoustic path also includes the solder ring between the microphone and PCB, and the through-hole in the PCB. The PCB acoustic hole must be large enough to give a good frequency response, but small enough for PCB design rules governing the distance from solder pads to drilled holes. The inside of the PCB acoustic hole must be un-plated so that solder will not wick into the hole and block the hole. A simple acoustic path design for a bottom-port SiSonic microphone is shown below.

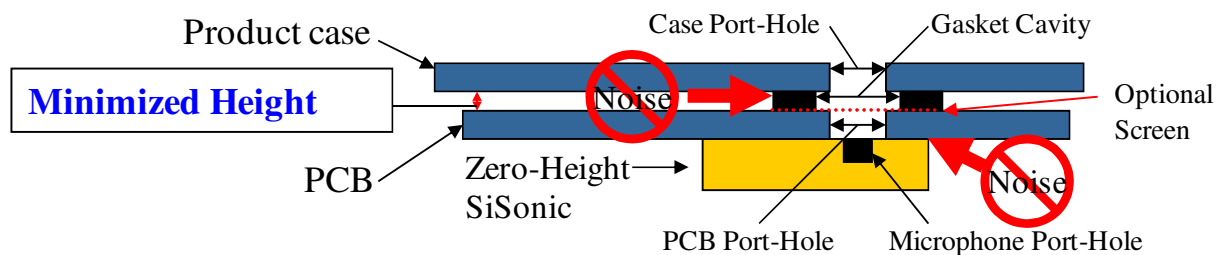

Figure 19: A Simple, Effective Acoustic Path Design for a Bottom-Port Microphone

Knowles provides free simulation services for acoustic path designs. These simulations show the approximate frequency response of SiSonic microphones with the gasket, case, and PCB to show if the frequency response is appropriate for the application. A summary of some of the recommended minimum dimensions for SiSonic acoustic path design is shown in the table below. Case holes and gasket ports can be non-circular, and will generally give similar performance as a circular hole with the same cross-sectional area.

Application Note

Microphone Package	Microphone Port-hole diameter	Recommended PCB Hole Diameter	Recommended Gasket Cavity Diameter	Recommended Case Hole Diameter
Mini Top-port	0.84 mm	N/A	$D > 1.5 \text{ mm}$	$1.5 > D \geq 1.0 \text{ mm}$
Mini Zero-Height SPK Zero-Height SPA Zero-Height SPY Zero-Height	0.25 mm	$0.9 > D > 0.4 \text{ mm}$	$D > 1.5 \text{ mm}$	$1.5 > D \geq 1.0 \text{ mm}$
Ultra Mini Top-port SPQ Top-port	0.50 mm	N/A	$D > 1.5 \text{ mm}$	$1.5 > D \geq 1.0 \text{ mm}$
Ultra Mini Zero-Height	0.25 mm	$0.6 > D > 0.3 \text{ mm}$	$D > 1.5 \text{ mm}$	$1.5 > D \geq 1.0 \text{ mm}$

Table 4: Recommended Acoustic Path Dimensions

3.2.2 Gasket Material and Assembly

A gasket must be made of acoustically opaque material that prevents sound from passing through it. The material must seal completely to the case and to the microphone or PCB. In a stack-up tolerance analysis, the gasket must form a compression fit in worst case (large gap) conditions, while compressing enough in small gap conditions to avoid bulges in the product case or the walls of the acoustic path. Good acoustic sealing prevents echo, noise, and frequency response problems that can result from resonant air volumes inside the product housing and from alternate paths to the mic port-hole.

The manufacturability of the mic-gasket-case assembly must also be considered. The assembly process must be designed to reliably align the holes in the gasket to the holes in the case and mic or PCB in volume production. Side-port or end-port gasket designs are more difficult to assemble, since the required gasket compression force is often parallel to the surface of the microphone and perpendicular to the usual case compression force as shown in figure (a) below. These types of gaskets can have problems with leaks during assembly, but a well-designed assembly process or a gasket design such as that shown in (b) can form good seals.

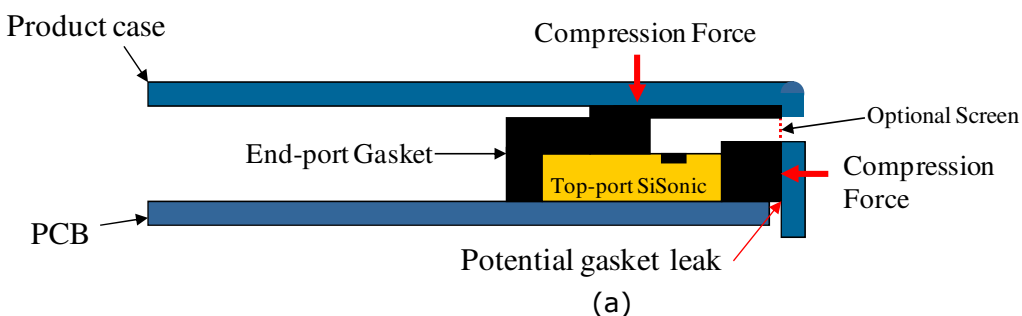

Application Note

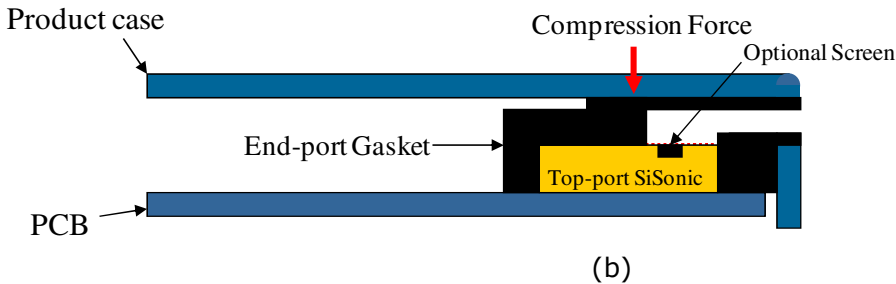

Figure 20: Example of an End-port Gasket Designs

Common gasket materials include various kinds of rubber and compressible, closed-cell foams. Knowles can design and source gaskets for SiSonic microphones, so if interested please contact Knowles for more information.

3.3 WIDEBAND FREQUENCY RESPONSE

Wideband and super wideband audio applications such as video and music recording use a frequency range beyond the traditional communications voiceband of 3.4 kHz, and are increasingly being used in new mobile product designs. A flat response is required from each part of the design from microphone through the entire signal processing path. Bottom-port SiSonic mics are well suited for wideband audio, but for top-port microphones the acoustic path can cause a peak in the desired frequency range. In this case, the flat response can be extended by adding acoustically resistive material such as a screen or mesh across the acoustic path of the microphone to dampen the peak. An optimized gasket design together with an acoustic resistance can extend the flat frequency response range of the top-port microphones to up to 15 kHz as shown in the figure below.

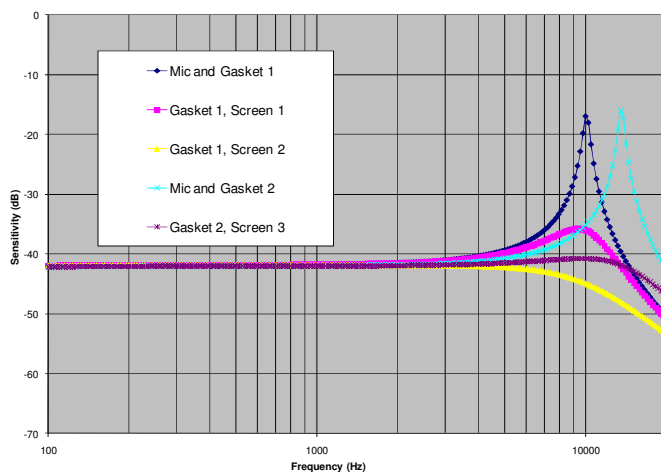

Figure 21: Using an Acoustic Resistance Screen to Extend the Flat Frequency Response

An acoustic resistance can be inserted between gasket and microphone (top-port mics), gasket and case, or PCB and gasket (bottom-port mics), and can also protect from dust and liquids.

Application Note

Examples of possible acoustic resistance screen locations are shown in the figures in the previous 2 sections of this app note. The acoustic resistance of a material is inversely proportional to its effective area, so a larger effective area has less resistance. A larger area also reduces the effect of variations in the material properties. The thickness of the material should be taken into account when calculating height stack-up tolerances and the compression of gasket materials.

3.4 ECHO AND NOISE PROBLEMS

Echo problems are most likely caused by a poor gasket seal. A leak in the gasket seal allows the speaker output or other noise to propagate inside the product case into the mic port, with little loss in strength. An easy way to test for a gasket leak is to block the acoustic port hole in the case. If the echo problem persists, then the echo is likely caused by a gasket leak and can be fixed by a gasket design change. A gasket leak may also cause the microphone to pick up audio noise from other sources such as a camera zoom motor or a chirping capacitor. The figure below shows a design with a gasket leak.

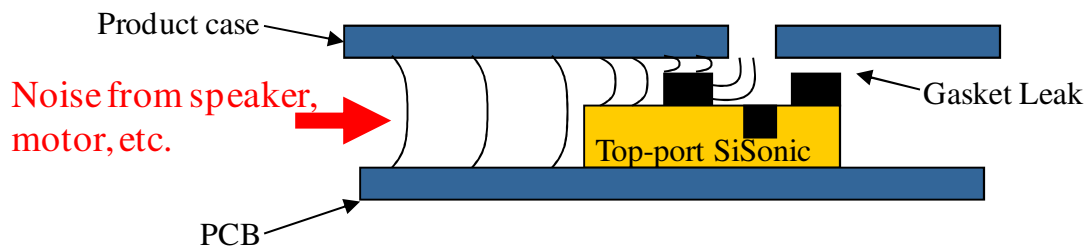

Figure 22: Echo or noise from a gasket leak.

In product use modes such as conference call mode the speaker output must be strong, so extra care must be taken to prevent echo. Assuming a good gasket design between the microphone and case, the strength of the speaker output at the microphone input is determined by the shortest path from the speaker to the microphone for sound traveling outside of the product case. The SPL output level of the speaker in open air decreases proportional to $1/R$, and the sound intensity with $1/R^2$. Once again, blocking the case port hole of the product can help determine if this is the source of echo. If the echo disappears when the case port hole is blocked, then the speaker output signal is too strong for the mic location. An external echo path such as this can be addressed with the following changes:

1. Reduce or limit the speaker output level.
2. Increase the path length from speaker to microphone by changing the location of the microphone and/or speaker in the design until the echo is reduced to an acceptable level.
3. Use echo cancellation software to remove the speaker signal from the mic input.

The IntelliSonic software package from Knowles includes echo cancellation, noise cancellation, and beam-forming functions for 2 microphone arrays for laptops using Windows 7/Vista.

Application Note

IntelliSonic can reduce echo and remove background noise signals to significantly improve SNR. Contact Knowles for further information about IntelliSonic.

3.5 PCB LAND PATTERN AND SOLDER STENCIL PATTERN

The PCB land pattern, the solder stencil pattern, the solder paste, and the reflow profile should be designed to yield reliable solder joints. The solder joints serve as the electrical connection, mechanical connection, and (for bottom-port mics) the acoustic seal between the mic and PCB. The recommended PCB land pattern for each SiSonic model matches the microphone solder pads dimensions. The solder stencil pattern must be optimized for production, and for bottom-port SiSonic models must use a broken solder ring such as that shown in the figure below.

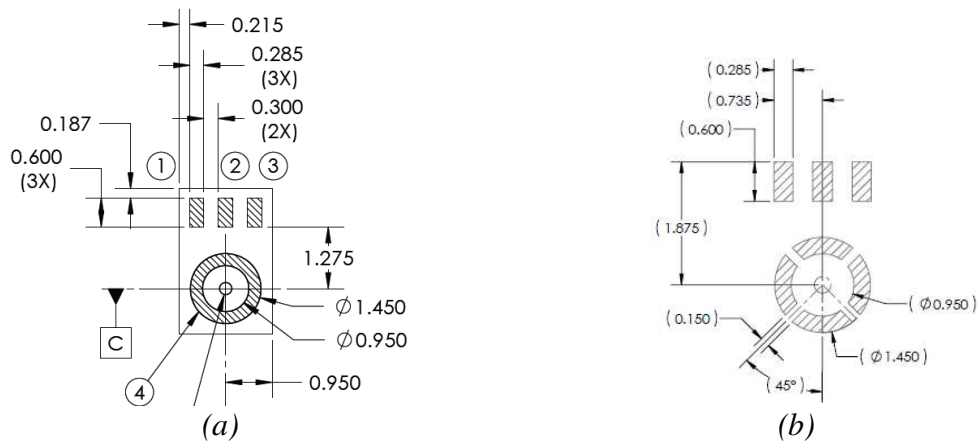

Figure 23: Comparison of SPY Zero-Height SiSonic (a) microphone solder pads and (b) a non-optimized reference solder stencil pattern with a broken solder ring.

The solder stencil and land patterns should be designed while considering PCB design rules, solder type, reflow profile, solder stencil thickness, etc. Design optimizations could include:

1. Increasing the land pattern size symmetrically to extend beyond the edge of the mic to allow for visual inspection of the solder joint.
2. Splitting round pads in the land pattern into two semicircles to allow for better out-gassing during reflow and reduce the occurrence of bubbles.
3. For bottom-port mics, reducing the PCB hole diameter or increasing the solder ring diameter to meet PCB design rule requirements.
4. Optimizing the solder reflow profile for each unique board design to ensure good solder joints between the mic and PCB.
5. For bottom-port mics, reducing the solder flux content of solder paste to prevent excessive flux from entering the mic port hole during reflow.
6. Increasing the solder stencil thickness to ensure adequate solder volume for good solder joints.
7. Reducing the solder stencil thickness to reduce solder volume to minimize the occurrence of solder balls.

Application Note

4.0 ELECTRICAL DESIGN CONSIDERATIONS

The interface signals for analog SiSonic microphones include power, output, ground, and sometimes additional signals. Since analog microphones have small amplitude outputs that are susceptible to noise, care should be taken with the trace routing to avoid potential noise problems. This section outlines recommendations for interfacing to each SiSonic signal, with an emphasis on the interface between the microphone output and the codec or chipset.

4.1 POWER SUPPLY

SiSonic microphones have no change in sensitivity with supply voltage, so the system designer only needs ensure that the supply voltage stays in the specified range, typically 1.5 to 3.6V. Because SiSonic has a separate power supply line and an internal voltage regulator, it is less susceptible to power supply noise than traditional ECMs. The Power Supply Rejection Ratio (PSRR) for SiSonic microphones is typically 50dB before any amplification, but even with this level of PSRR strong power supply noise can cause significant noise in the microphone output. For example, a 10mV RMS noise signal attenuated by 50dB still results in a 30 μ V RMS ripple in the microphone output. This can be significant compared to the 11 μ V RMS typical noise floor of the microphone, and is equivalent to an acoustic input of about 46dB SPL. If there is strong noise in the microphone power supply, then shunt capacitors may be added to stabilize the supply as shown in Figure 28.

4.2 GROUND

All microphone ground pads should be connected to an analog ground plane through a short, wide trace that is not daisy-chained from device to device. If there is strong noise in the ground plane, some designs may benefit from a series ferrite bead in the ground path to isolate the microphone from the noise. Amplified SiSonic models are designed to be drop-in replacements for non-amplified models of the same package size, with one ground pad changed to be the gain control pad. If it is anticipated that an amplified mic output may be needed in a design, the gain control pad can be connected to ground through appropriate components to set the desired gain (see the next section.) If non-amplified SiSonic is used in the final design, then the gain pad components can be left unpopulated and the pad will be grounded internally by the non-amplified mic.

4.3 GAIN CONTROL

The gain of amplified SiSonic microphones is set using a resistor and capacitor connected to the Gain Control terminal of the microphone, as shown in the circuit below.

Application Note

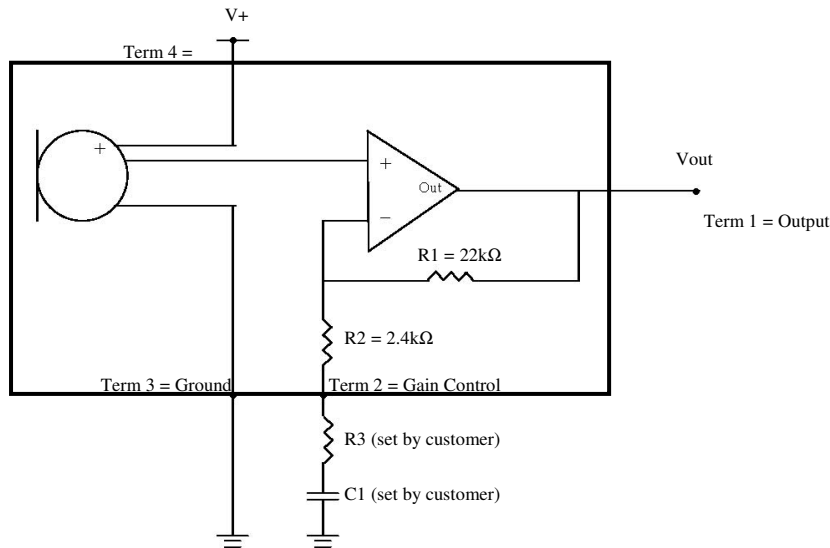

Figure 24: Gain control circuitry for amplified SiSonic

The value of R3 is chosen to give the desired gain value, with a maximum gain of 20dB when R3 is 0Ω. C1 allows proper DC biasing of the amp input, and should be chosen so that the corner frequency (C.F.) of the high-pass filter formed by C1, R2, and R3 is well below the acoustic range. If no additional gain is required, the gain terminal can be tied directly to the output terminal for the same sensitivity as a non-amplified SiSonic. The gain terminal cannot be left floating since this will add noise to the mic output. R3 and C1 are calculated using the following formulas:

Setting Gain Formulas:

Gain of non-inverting Op-Amp is determined as:

$$G = 1 + \left\{ \frac{R1}{R2 + R3} \right\} \quad \text{Gain (dB)} = 20 * \log(G)$$

High-pass-filter Corner Frequency:

$$\text{C.F.} = 1 / \{ 2\pi * (R2 + R3) * C1 \}$$

Figure 25: Formulas for calculating gain control component values

The R and C components should be located as near to the microphone as possible, since any noise picked up in the Gain Control terminal could feed into the output of the microphone.

4.4 MICROPHONE TO CODEC INTERFACE CIRCUIT

The interface circuit between an analog SiSonic microphone output and the codec or baseband chipset can be very simple depending on the design needs. If the codec input is self-biasing, then the only interface component required is a coupling capacitor. This capacitor forms a high pass filter with the input impedance of the codec or chipset, so is typically in the μF range for a 3dB point <100Hz. Some chipsets require an external DC bias circuit after the coupling capacitor,

Application Note

and chipset documentation should be consulted for the recommended audio interface circuit. Unlike ECMs, SiSonic microphones do not need a resistor from the output to power since they have a separate power terminal and a built-in voltage regulator.

In general, the output trace should be kept as short as possible, and should be routed over or between analog ground planes to shield it from noise. The figure below shows a simple microphone interface circuit.

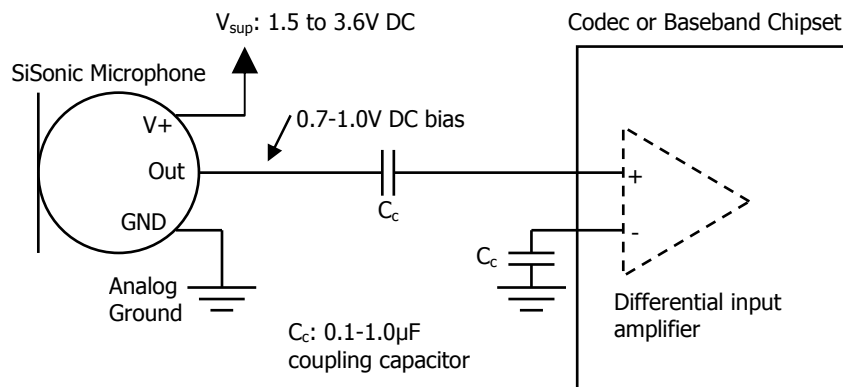

Figure 26: Example of a simple SiSonic interface circuit

4.5 SISONIC 2-WIRE CIRCUIT

Analog SiSonic microphones require a 3-wire interface, but for some applications like headsets a 2-wire interface is needed to reduce the number of conductors running through a cable. The 2-wire circuit shown in the figures below uses a load circuit on the mic output node to generate an AC current in the power node, which becomes the output of the 2-wire circuit. The output is converted into a voltage when the current flows through the load resistor connected to the 2-wire output.

Application Note

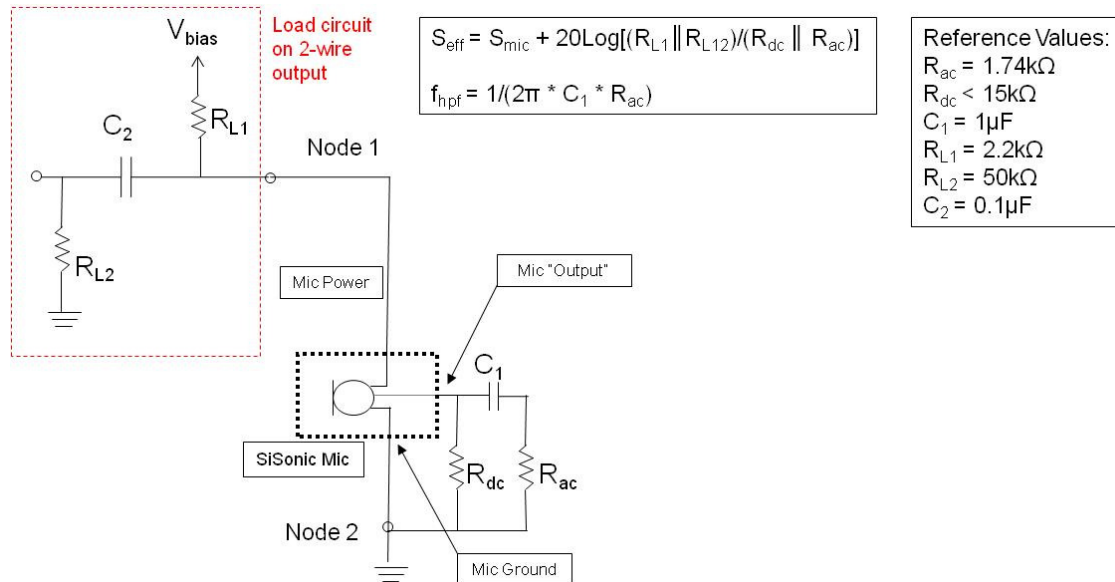

Figure 27: Circuit for 2-wire SiSonic microphone interface.

4.6 MINIMIZING NOISE PICK-UP

Many product designs like tablets and mobile handsets require the microphone(s) to be near noise sources like antennas and power amplifiers. RF frequency signals are not themselves a problem since they are well above audio frequencies, but many wireless standards use TDMA technologies where data is sent in bursts or packets. The frequency of these packets usually falls in the audio range and can induce an undesirable “buzz” in the audio signal.

In designs where noise is a concern, there are a number of techniques a designer can use to protect the audio signal from noise.

1. Use MaxRF SiSonic models that have embedded RC filters on each trace to prevent RF noise in traces from getting into the mic output. (See section 2.3)
2. Keep signal traces as far as possible from potential noise sources.
3. Route traces on inner PCB layers protected by ground layers, and keep trace lengths as short as possible. Ideally Out and Vdd are connected directly to middle layers of the PCB under the mic with vias.
4. Surround the microphone package with a ground plane if possible.
5. Add capacitor(s) between the microphone power and ground to help remove power supply noise.
6. Use series ferrite beads (chokes) and RF shunt capacitors to reduce RF noise in traces. Place ferrite beads near the mic or where traces come out from middle PCB layers, and place caps on the chipset side of the ferrite beads.
7. DO NOT route the output and Vdd signals in parallel with no ground between, as this could ruin cross-talk and multi-tone performance.

Application Note

8. Use Differential or Digital SiSonic to minimize noise picked up by the output traces, or configure single-ended SiSonic differentially by using the output and ground as the two sides of a differential pair.
9. Place the microphone and associated circuitry in shielded areas of the design to reduce the potential for RFI and EMI pick-up.

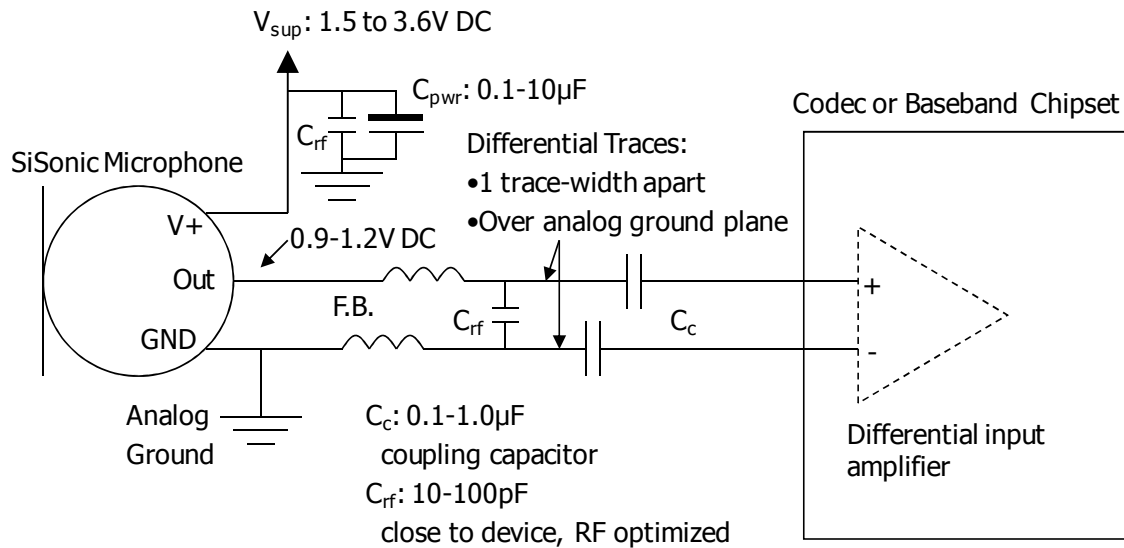

Figure 28: Single-ended SiSonic design with noise protection techniques