



Chipsmall Limited consists of a professional team with an average of over 10 year of expertise in the distribution of electronic components. Based in Hongkong, we have already established firm and mutual-benefit business relationships with customers from,Europe,America and south Asia,supplying obsolete and hard-to-find components to meet their specific needs.

With the principle of “Quality Parts,Customers Priority,Honest Operation,and Considerate Service”,our business mainly focus on the distribution of electronic components. Line cards we deal with include Microchip,ALPS,ROHM,Xilinx,Pulse,ON,Everlight and Freescale. Main products comprise IC,Modules,Potentiometer,IC Socket,Relay,Connector.Our parts cover such applications as commercial,industrial, and automotives areas.

We are looking forward to setting up business relationship with you and hope to provide you with the best service and solution. Let us make a better world for our industry!



Contact us

Tel: +86-755-8981 8866 Fax: +86-755-8427 6832

Email & Skype: info@chipsmall.com Web: www.chipsmall.com

Address: A1208, Overseas Decoration Building, #122 Zhenhua RD., Futian, Shenzhen, China



Standalone and Serial-to-Wi-Fi b/g/n intelligent modules

Datasheet - preliminary data

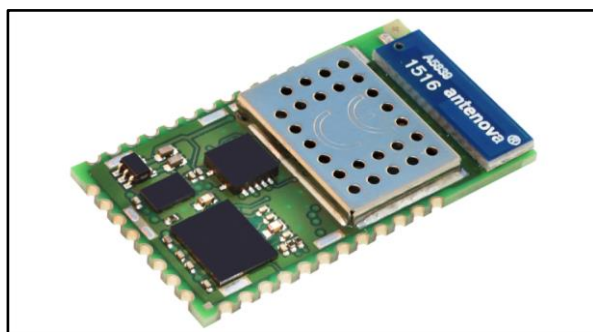

Features

- 2.4 GHz IEEE 802.11 b/g/n transceiver
 - High performance STM32F439
 - ARM® Cortex®-M4
 - 256 KB SRAM
 - 2 MB embedded high-speed Flash memory
 - 1 MB Flash memory for user storage, extendable via SD/MMC interface or external SPI Flash
 - Integrated TCP/IP protocol stack
 - 8 simultaneous TCP or UDP clients and 2 socket servers (supporting up to 8 clients each)
 - Secured socket and upper layers (i.e. HTTPS) supporting up to TLS 1.2, including AES (128, 256), hash (MD5, SHA-1, SHA-256) and RSA (1024, 2048)
 - Web server supporting SSI
 - Open, WEP, WPA2 PSK, WPA2 Enterprise
 - WPS for station
 - System modes: Station, IBSS, and miniAP (supporting up to 5 Stations)
 - miniAP easily provisioned (SSID, PWD)
 - Fast Wi-Fi re-association after reset
 - Secure Firmware and FileSystem updates Over The Air (OTA)
- TX power
 - 18.3 dBm @ 1 Mbps DSSS
 - 13.7 dBm @ 54 Mbps OFDM
 - RX sensitivity
 - -96.0 dBm @ 1 Mbps DSSS
 - -74.5 dBm @ 54 Mbps OFDM
 - 19 configurable GPIOs available
 - UART and SPI interface to host system
 - Advanced low-power modes
 - Standby with RTC: 43 μ A
 - Sleep = 3 mA
 - Idle connected (DTIM=1) = 5 mA
 - RX traffic 105 mA typical
 - TX traffic 260 mA typical @ 10 dBm
 - AT command set interface through UART
 - SPI interface with simple protocol
 - Application subsystem
 - Embedded real-time MicroPython environment for customer applications and on-board development
 - MicroPython API library for easy access to Wi-Fi subsystem capabilities and device peripherals (i.e. UART, SPI, I²C)
 - Small form factor: 26.92 x 15.24 x 2.35 mm
 - Single voltage supply (3.3 V typical)
 - Antenna options: integrated antenna/U.FL connector
 - Industrial temperature range: -40°C to 85°C
 - FCC/CE/IC certified
 - RoHS compliant

Applications

- Smart appliances
- Industrial control and data acquisition
- Home automation and security systems
- Wireless sensors
- Cable replacement
- Medical equipment
- Machine-to-machine communication

Contents

1	Description.....	5
2	Schematic diagram.....	7
3	General electrical specifications.....	8
4	Digital interface specifications.....	9
5	RF characteristics	10
6	Pinout description.....	11
7	Host interfaces	14
	7.1 UART interface.....	14
	7.2 SPI interface.....	14
8	Mechanical dimensions	18
9	Module reflow	20
10	Regulatory compliance	21
	10.1 RoHS compliance	21
	10.2 RF certifications	21
	10.2.1 FCC and IC.....	22
	10.2.2 CE.....	23
11	Module marking and traceability.....	24
12	Ordering information.....	26
13	Revision history	27

List of tables

Table 1: Absolute maximum ratings	8
Table 2: Operating conditions and input power specifications	8
Table 3: Digital interface specifications, I/O pins	9
Table 4: RF characteristics	10
Table 5: Pinout description	11
Table 6: GPIOs main and alternate functions.....	12
Table 7: SPI signals	15
Table 8: Soldering values	20
Table 9: RF certification summary	21
Table 10: Antennas used for certification of SPWF04SC	22
Table 11: Titanis antenna characteristics	22
Table 12: Module product ID	25
Table 13: Ordering information	26
Table 14: Document revision history	27

List of figures

Figure 1: SPWF04S block diagram	7
Figure 2: UART connection with host device.....	14
Figure 3: SPI connection with host device.....	15
Figure 4: Single 1 byte transaction	16
Figure 5: TX master transaction	16
Figure 6: RX master transaction	16
Figure 7: Master RX multiple messages.....	17
Figure 8: Module dimensions.....	18
Figure 9: Module footprint.....	19
Figure 10: Soldering profile.....	20
Figure 11: CE Label	23
Figure 12: SPWF04SA front side.....	24
Figure 13: SPWF04SA bottom side.....	24

1 Description

The SPWF04SA and the SPWF04SC are ready-to-use Wi-Fi modules conceived for Internet of Things (IoT) applications. The modules integrate a Cortex-M4-based STM32 microcontroller and a powerful Wi-Fi transceiver, compliant with IEEE 802.11 b/g/n standard for the 2.4 GHz band.

The modules are cloud compatible thanks to the complete protocol package, which includes application and security layers. They can operate in serial-to-Wi-Fi and standalone mode, with customer applications developed in the subsystem based on the MicroPython environment.

The modules are configured around a single-chip 802.11 transceiver with integrated PA and comprehensive power management subsystem, and an STM32F4 microcontroller with UART/SPI interface and an extensive GPIO suite; they also incorporate timing clocks and a voltage regulator.

The SPWF04SA module is configured with a highly-efficient, embedded micro 2.4 GHz ISM band antenna, or with an external U.FL antenna connector (SPWF04SC); both are certified FCC/IC and CE.

With low power consumption and an ultra-compact (2.7 x 1.5 cm) footprint, the modules are ideal for fixed and mobile wireless applications, as well as challenging battery-operated applications.

The SPWF04Sx parts are released with an integrated full featured TCP/IP protocol stack with added web server and additional application service capabilities, including REST API for accessing files on servers in the cloud and support for dynamic web pages with SSI functions to easily interact with the module and the host processor over the air. Application note AN4965 on www.st.com provides details on HTTP server capabilities.

Multiple higher level protocols over TCP are supported by the module including: HTTP, MQTT, SMTP, and WebSockets to easily connect application to the cloud. Multiple protocols supported over UDP include: TFTP, SNTP and mDNS; the module also includes IPv6 networking capabilities.

The SW package also has an AT command layer interface for user-friendly access to the stack functionalities via the UART serial port and an SPI interface supporting master and slave messages from and to the host processor respectively (see user manual UM2114 on www.st.com).

The SPWF04Sx includes a MicroPython scripting engine to enable simple and fast custom application development on the module MCU: no external MCU is needed and the customer application runs directly on the module. The interpreter implementation is fully compatible with the standard MicroPython version 1.6. In standalone mode, MicroPython use Wi-Fi interfaces and MCU peripherals such as UART, SPI, I2C, GPIOs via standard MicroPython APIs (see application note AN4964 on www.st.com).

1 MB of the internal Flash is dedicated to store the user file system while a hardware interface allows the usage of an external memory via SPI/SDIO (Serial Flash/SD Card) to further extend the file system storage capabilities.

The module supports WPA2-Personal and WPA2-Enterprise security and WPS (Wi-Fi protected setup).

For secure end-to-end communication with the cloud, an SSL/TLS stack is embedded in every module, with no licensing charge. See application note AN4963 on www.st.com for details on security.

Description**SPWF04SA, SPWF04SC**

The module firmware may be updated at any time via UART and over-the-air (FOTA); the FOTA operation can be performed with different level of security, as described in AN4963.

ST may update the module firmware at any time; check regularly for documentation and firmware updates on www.st.com/wifimodules.

2 Schematic diagram

Figure 1: SPWF04S block diagram

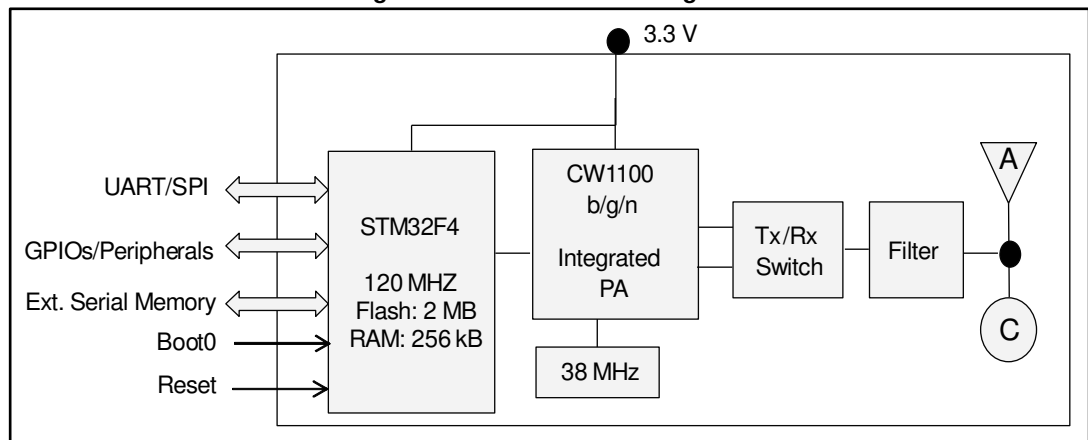

3 General electrical specifications

Table 1: Absolute maximum ratings

Rating	Min.	Typ.	Max.	Unit
Voltage supply	-0.3	-	4.0	V
V _{in} for 5 V tolerant pins	-0.3	-	5.5	V
V _{in} for all other pins	-0.3	-	3.6	V
Storage temperature range	-55	-	105	°C

Table 2: Operating conditions and input power specifications

Parameter		Test condition		Min.	Typ.	Max.	Unit		
Operating temperature range		Industrial		-40		85	°C		
3.3 V supply	Input supply voltage	3.3 V supply input		3.1	3.3	3.6	V		
	Standby	Both the STM32 and the radio are in standby power states			43		μA		
	Sleep	The STM32 is in stop power state and the radio is in sleep power state			3		mA		
	Low power state	The STM32 is active and the radio is in sleep power state			33		mA		
	TX (@ max power)	802.11b	1 Mbps DSSS			360		mA	
			802.11g	6 Mbps			350		mA
		802.11n		54 Mbps			290		mA
			802.11n		MCS0			350	
	RX	802.11b		MCS7			280		mA
		802.11b					105		mA
802.11g					105		mA		
		802.11n					105		mA

Note: Measure preformed at T_a = 25 °C, V_{DD} = 3.3 V on channel 1.

4 Digital interface specifications

Table 3: Digital interface specifications, I/O pins

Parameter		Test condition	Min.	Typ.	Max.	Unit
Inputs	VIH		2.3	-	3.6	V
	VIL		0		0.9	V
Outputs	VOH	IOH=4 mA	2.4		3.6	V
	VOL	IOL=4 mA	0		0.4	V

5 RF characteristics

Table 4: RF characteristics

Parameter		Test condition	Value	Unit
RX sensitivity ⁽¹⁾	11b, 1 Mbps		-96	dBm
	11b, 2 Mbps		-93	dBm
	11b, 5.5 Mbps		-91	dBm
	11b, 11 Mbps		-87	dBm
	11g, 9 Mbps		-89.5	dBm
	11g, 18 Mbps		-86	dBm
	11g, 36 Mbps		-80	dBm
	11g, 54 Mbps		-74.5	dBm
	11n, MCS1, 13 Mbps		-86.5	dBm
	11n, MCS3, 26 Mbps		-81.5	dBm
	11n, MCS5, 52 Mbps		-74	dBm
	11n, MCS7, 65 Mbps		-71	dBm
Channel-to-channel de-sensitivity	CH1 to 14	11g, 54 Mbps, 10%PER	1	dB
Maximum input signal	CH7	11g, 54 Mbps	-20	dBm
Adjacent channel rejection	11Mbps		38	dBc
	9 Mbps		20	dBc
	54 Mbps		4	dBc
	MCS1		24	dBc
	MCS7		3	dBc
Max TX output power ⁽¹⁾	11b, 1 Mbps	@ 11b spectral mask	18.3	dBm
	11b, 11 Mbps		18.3	dBm
	11g, 9 Mbps	@ 11g spectral mask	18.3	dBm
	11g, 54 Mbps	EVM = -27 dB, 4.5%	13.7	dBm
	11n, MCS0	@ 11n spectral mask	18.3	dBm
	11n, MCS7	EVM = -27 dB	13.5	dBm
On-board antenna gain		Average	-1.2	dBi

Notes:

⁽¹⁾Output power and sensitivities are measured with a 50 Ω connection at the antenna port.

6 Pinout description

Table 5: Pinout description

Signal name	Type	Pin number	Function	Notes
GPIOs - general purpose input/output				
GPIO[0] – GPIO[18]	I/O	See Table 6: "GPIOs main and alternate functions" for corresponding pin numbers, main and alternate functions		
Host interface ⁽¹⁾				
RXD/MOSI	I	8		5 V tolerant
TXD/MISO	O	6		5 V Tolerant
CTS/nCS	I	9		Active low, 5 V tolerant
RTS/CLK	O	10		5 V tolerant
Reset ⁽²⁾				
RESETn	I	3	Reset input	Active low for 5 ms with pull up to 2.5 VDC. Not 5 V tolerant
Bootloader				
BOOT0	I	2	Boot loader ⁽³⁾	
External memory interface ⁽⁴⁾				
SDIO CLK / SPI CLK		31		
SDIO D0 / SPI MISO		32		
SDIO CMD / SPI MOSI		33		
Other pins				
VCC (3.3 V)		24	Voltage Supply	Decouple with 10 μ F capacitor
Ground		23	Ground	
Ground Paddle		25	Ground	Add plenty of Ground vias for thermal dissipation and ground
LSE		34		
HSE		35		
SWD I/O		26		
SWD CLK		29		

Notes:

⁽¹⁾See [Section 7: "Pinout description"](#) for a UART and SPI selection modes and interface details.

⁽²⁾In order to recover from unexpected behavior, the HOST processor, when connected, could conveniently control the RESETn pin of the module.

⁽³⁾To enable the firmware download, pin BOOT0 needs to be high during power up. RESETn needs to be pulled low at least 5 ms to initiate the firmware download sequence.

⁽⁴⁾Automatic detection via the configuration variable ext_volume.

Table 6: GPIOs main and alternate functions

Signal name	Pin n°	Main Function ⁽¹⁾	Alternate function			Electrical notes
			System function ⁽²⁾	Peripheral driver ⁽³⁾	MicroPython Interfaces ⁽⁴⁾	
GPIO[0]	16	General Purpose input/output	Restore to factory setting ⁽⁵⁾	ADC		Input pull down and 5 V tolerant
GPIO[1]	17	General Purpose input/output		ADC		Input pull down and 5 V tolerant
GPIO[2]	19	General Purpose input/output		PWM	TX UART	Floating and 5 V tolerant
GPIO[3]	1	General Purpose input/output	Ext memory: SPI_CS			Input pull down and 5 V tolerant
GPIO[4]	18	General Purpose input/output			I2C SDA	
GPIO[5]	20	General Purpose input/output			I2C SCL	
GPIO[6]	22	General Purpose input/output	WakeUp sleep Inhibit ⁽⁶⁾			Input pull down and 5 V tolerant
GPIO[7]	13	MiniAP: General purpose input/output STA: WPS PushButton	STA/MiniAP switch (startup) ⁽⁷⁾		RTS UART	
GPIO[8]	4	General Purpose input/output	MicroPython selection mode ⁽⁸⁾			
GPIO[9]	7	General Purpose input/output	SPI HOST interface: SPI nHostInterrupt ⁽⁹⁾			
GPIO[10]	5	General Purpose input/output	LED Drive: module running ⁽¹⁰⁾			
GPIO[11]	11	General Purpose input/output			RX UART	
GPIO[12]	12	General Purpose input/output			CTS UART	
GPIO[13]	15	LED Drive: Wi-Fi Link Up			MISO SPI	
GPIO[14]	14	LED Drive: power Up			MOSI SPI	
GPIO[15]	21	General Purpose input/output		DAC	SCK SPI	
GPIO[16]	27	General Purpose input/output		ADC		
GPIO[17]	28	General Purpose input/output				
GPIO[18]	30	General Purpose input/output				

Notes:

⁽¹⁾Main Function is set at the module initialization when "factory" configuration is used. The GPIOs are all set as input pull down

with the exception of GPIO7 that is set as input pull up.

⁽²⁾Alternate System Functions are activated when the related pin is connected or when the command/specific configuration is used.

⁽³⁾Alternate Peripheral Drivers are activated when the corresponding peripheral command is used.

⁽⁴⁾Alternate MicroPython Functions are activated when the related class is initialized.

⁽⁵⁾To perform the restore of the factory variable set, the pin GPIO0 must be high during powerup.

⁽⁶⁾This alternate function is running when low power mode variable is enabled. Ext. RC is suggested in order to stabilize the signal. The value is high to wakeup the module.

⁽⁷⁾To enable the STA or MiniAP switch, the GPIO[7] needs to be low together with the HW reset.

⁽⁸⁾When this GPIO is high at the startup the module enters the MicroPython mode.

⁽⁹⁾To select the SPI as host interface, this GPIO must be driven high at the reset time.

⁽¹⁰⁾Selected by using the configuration variable Blink_led.

Note: Use an external pull up/pull down connected to a given GPIO to prevent unwanted behavior.

7 Host interfaces

SPWF04S supports UART and SPI interfaces for connecting the module with a host processor. The pins to be used in the two possible configurations are indicated in the [Table 5: "Pinout description"](#). By default, SPWF04S works using the UART port with AT commands. To switch SPI on, the pin corresponding to GPIO[9] must be driven low during boot to force the device to handle incoming commands over SPI instead of UART.

7.1 UART interface

The SPWF04S can be interfaced with an external host using the UART interface shown in [Figure 2: "UART connection with host device"](#). This configuration is used by default, with four signals including RTS and CTS for HW flow control. The UART baud rate is configurable in the 1200-921600 range. The default configuration is 115200/8/n/1 with flow control disabled.

Figure 2: UART connection with host device

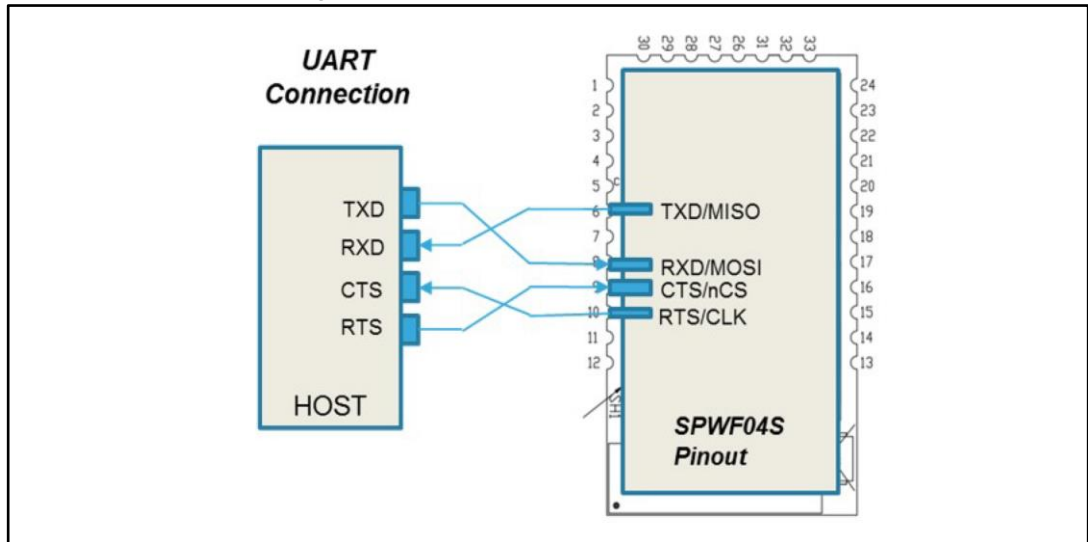

7.2 SPI interface

The SPWF04S can be interfaced as a slave with an external host by using the SPI interface as shown in [Figure 3: "SPI connection with host device"](#). There are four SPI signals and an additional host interrupt signal. SPI signals are detailed in the [Table 7: "SPI signals"](#). This Interrupt signal allows the SPI slave to alert the SPI master that it has data to send. In turn, the SPI master needs to assert the GPIO connected to the SPWF04S chip select and to start the CLK signal to send data to the slave.

Figure 3: SPI connection with host device

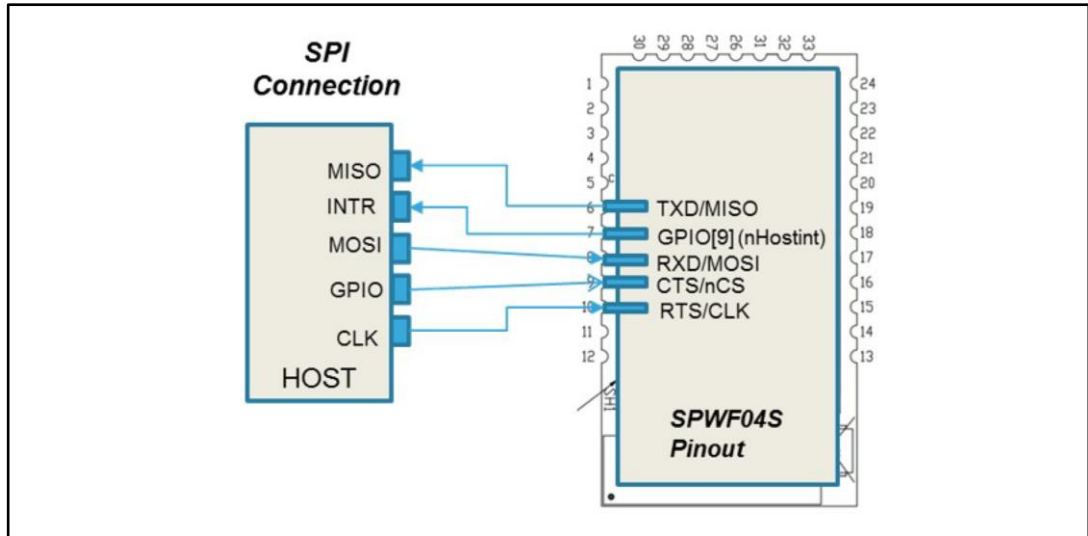

Table 7: SPI signals

SPWF04S signal name	Description
RTS/Clk	Clock (up to 22 MHz) from MCU to SPWF04S
CTS/nCS	Active Low indicates the selection of the slave before a data transmission from the Master
GPIO[9] (nHostInt)	nHostInt. Interrupt sent from the SPWF04S to the host to indicate the transmission of data from the slave
RXD/MOSI	Data from Host to SPWF04S
TXD/MISO	Data from SPWF04S to the Host

The host SPI can work up to the speed of 22 MHz. The communication between host and SPWF04S is handled in half duplex.

Data is transmitted and received with the most significant bit first (SPI mode 0). That means the clock polarity (CPOL) and the clk phase (CPHA) used to configure SPI are both set to zero. The mode0 is commonly used as default for microcontrollers.

Figures from [Figure 4: "Single 1 byte transaction"](#) to [Figure 7: "Master RX multiple messages"](#) detail the signaling over the SPI. In particular, [Figure 4: "Single 1 byte transaction"](#) shows a single 1-byte transaction in mode 0. T_{lead} should be at least half a clock cycle long, and so its value depends on the host clock frequency. SPI data is latched by the master and slave using the CLK signal. So, when data needs to be transferred, the MISO and MOSI signals change between each clock. After each single request sent from master to the slave, the Master MUST wait for a confirmation message sent from the slave. The message is notified to the master using the nHost Irq. All the data transferred in both directions are packed using a well defined packet format described in the User Manual.

Figure 4: Single 1 byte transaction

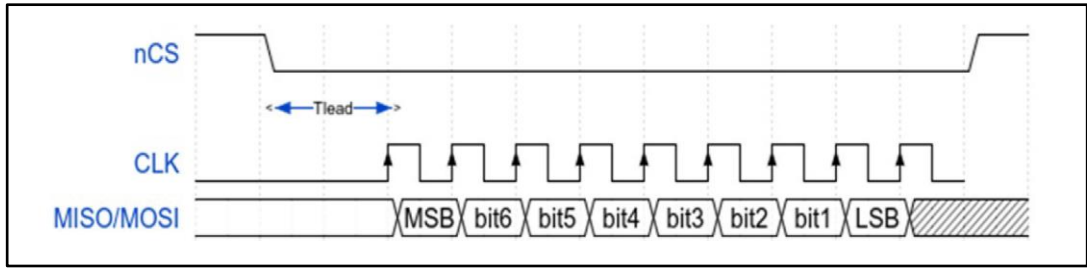

The [Figure 5: "TX master transaction"](#), [Figure 6: "RX master transaction"](#) and [Figure 7: "Master RX multiple messages"](#) show a Master TX transaction and a Master RX transaction, respectively. The communication starts with the host sending the write SYNC word (0x02), followed by header information, and then payload, when applicable. Once the command has been analyzed by the device, it asserts the IRQ interrupt line. Then the host detects the interrupts and then writes the read SYNC word (0x02) and starts to generate the clock. The device then clears the interrupt line and prepares the response. The host then reads continuously until the SYNC pattern is detected. All data until that point is discarded. The SYNC word is then followed by headers and then payload, when applicable.

Figure 5: TX master transaction

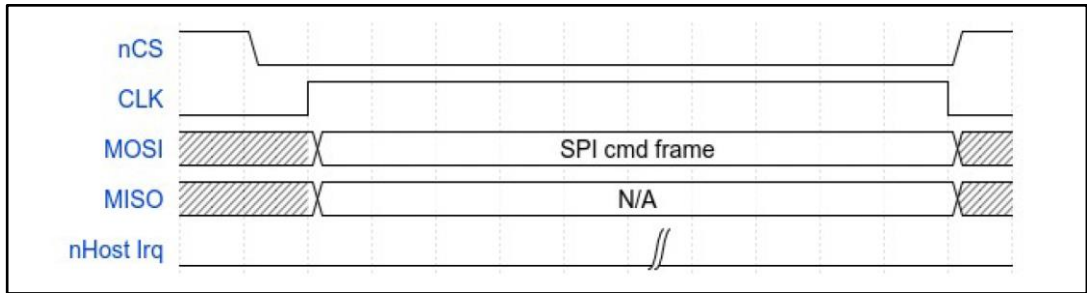
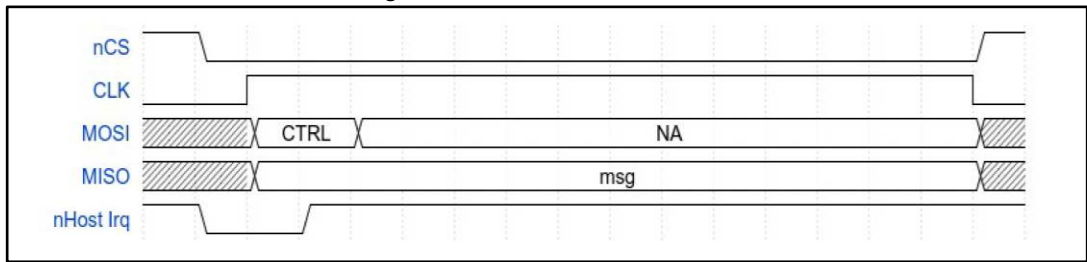
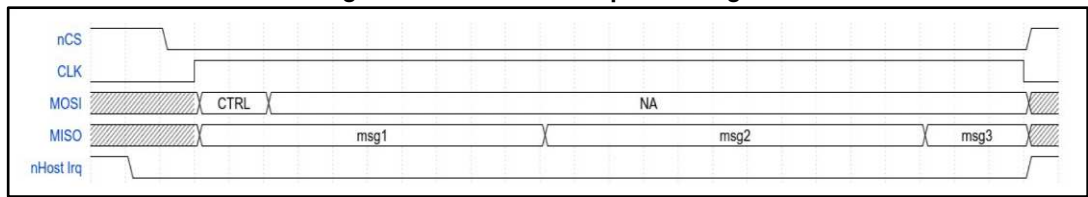

Figure 6: RX master transaction



In case of multiple messages sent from slave to master, the nHost Irq line is asserted low until the slave has data to be sent, as shown in [Figure 7: "Master RX multiple messages"](#).

Figure 7: Master RX multiple messages



Refer to the UM2114 for a complete description of the SPI packets used in SPWF04S.

8 Mechanical dimensions

In order to meet environmental requirements, ST offers these devices in different grades of ECOPACK® packages, depending on their level of environmental compliance. ECOPACK® specifications, grade definitions and product status are available at: www.st.com. ECOPACK® is an ST trademark.

Figure 8: Module dimensions

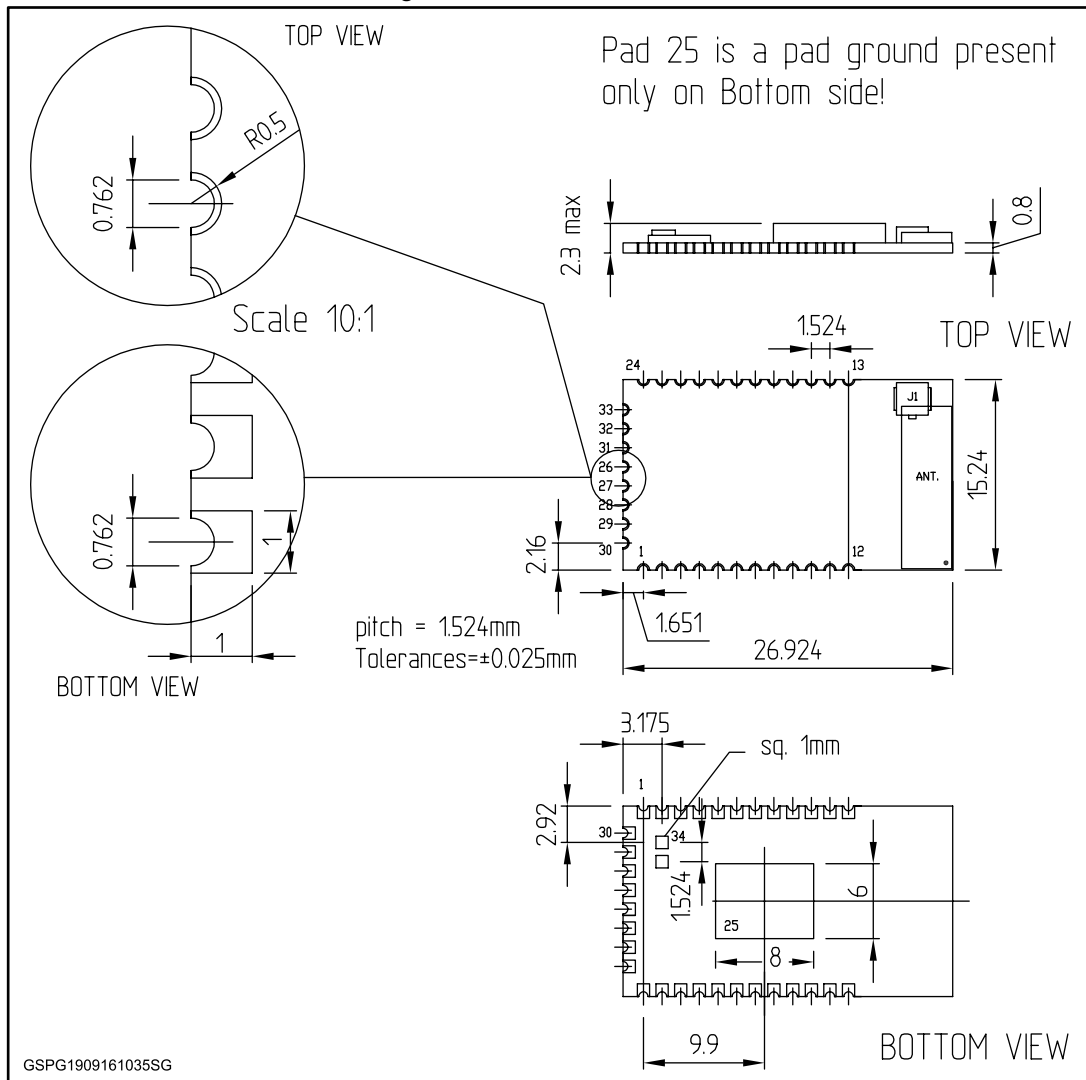

Note: An antenna area of 217 x 520 mils must be free of any ground metalization or traces under the unit. The area extending away from the antenna should be free from metal on the PCB and housing to meet expected performance levels. Pin 25 is the required paddle ground and is not shown in this diagram.

Figure 9: Module footprint

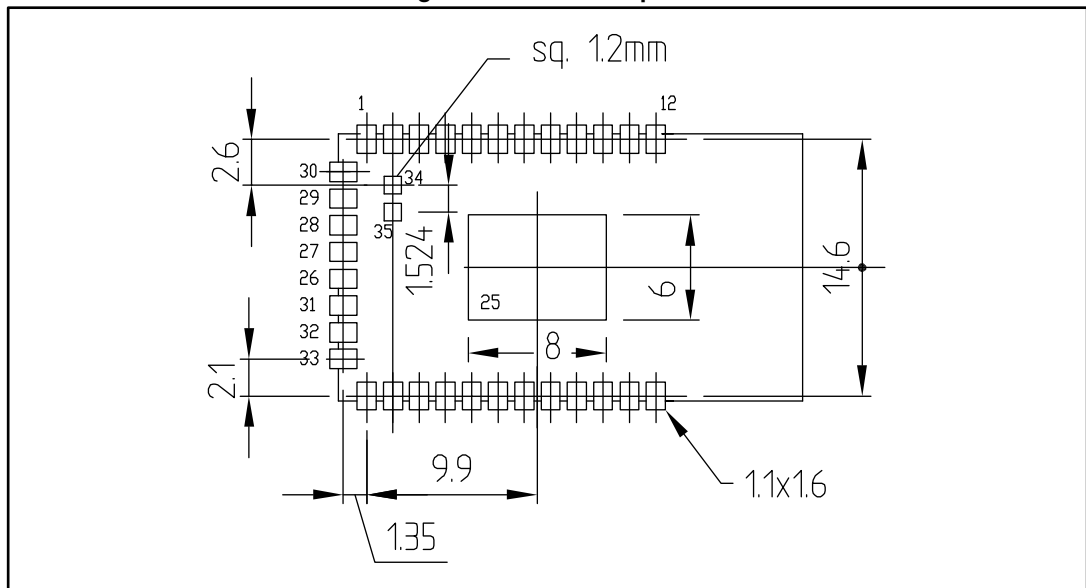

Note: PCB design requires a detailed review of the center exposed pad. This pad requires good thermal conductivity. Soldering coverage should be maximized and checked via x-ray for proper design. There is a trade-off between providing enough soldering for conductivity and applying too much, which allows the module to "float" on the paddle creating reliability issues. ST recommends two approaches, a large center via that allows excess solder to flow down into the host PCB with smaller vias around it, or many smaller vias with just enough space for the viscosity of the chosen solder/flux to allow some solder to flow into the smaller vias.

Either of these approaches must result in 60% or more full contact solder coverage on the paddle after reflow. ST strongly encourages PCB layout teams to work with their EMS providers to ensure vias and solder paste designs that will result in satisfactory performance.

9 Module reflow

The SPWF04SA and SPWF04SC are surface mount modules with a 6-layer PCB. The recommended final assembly reflow profiles are indicated below.

The soldering phase must be executed with care: in order to prevent an undesired melting phenomenon, particular attention must be paid to the setup of the peak temperature.

The following are some suggestions for the temperature profile based on the IPC/JEDEC J-STD-020C, July 2004 recommendations.

Table 8: Soldering values

Profile feature	PB-free assembly
Average ramp-up rate ($T_{S_{MAX}}$ to T_P)	3 °C/sec max
Preheat: Temperature min. (T_s min.) Temperature max. (T_s max.) Time (T_s min. to T_s max) (ts)	150 °C 200 °C 60 - 100 sec
Critical zone: Temperature T_L Time T_L	217 °C 60 - 70 sec
Peak temperature (T_P)	240 + 0 °C
Time within 5 °C of actual peak temperature (T_P)	10 - 20 sec
Ramp-down rate	6 °C/sec
Time from 25 °C to peak temperature	8 minutes max.

Figure 10: Soldering profile

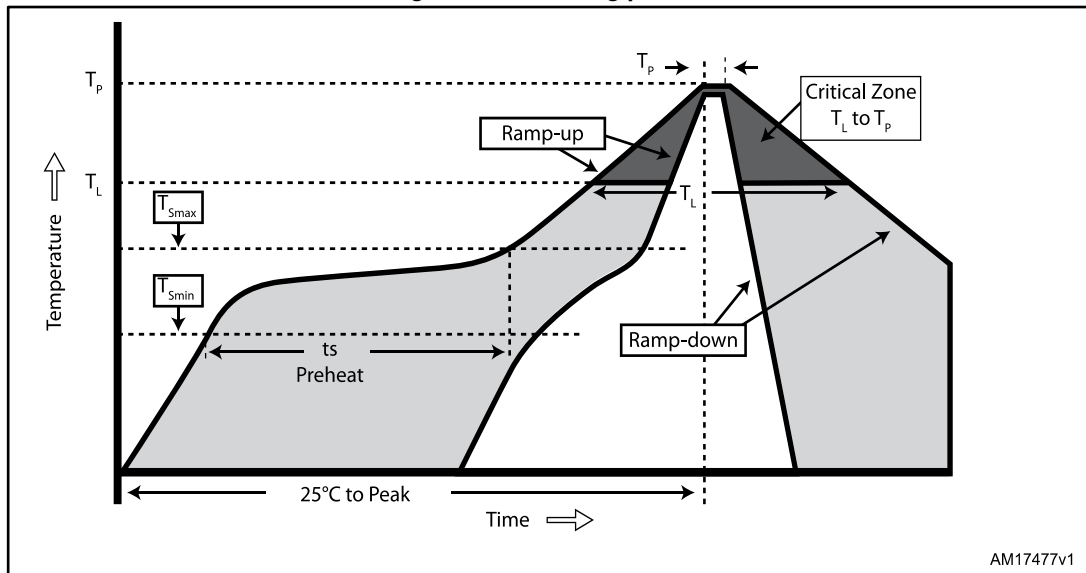

AM17477v1

10 Regulatory compliance

10.1 RoHS compliance

In order to meet environmental requirements, ST defines different grades of ECOPACK® packages, depending on their level of environmental compliance. ECOPACK® specifications, grade definitions and product status are available at: www.st.com.

ECOPACK® is an ST trademark.

SPWF04S modules comply with the ECOPACK2 level of RoHS compliance grade.

The material declaration file is available at: www.st.com.

10.2 RF certifications

The RF certifications obtained for the SPWF04S modules are summarized below.

Table 9: RF certification summary

Directives	ID	Certified Rules and STD	Notes
FCC	S9NSPWFS04	FCC part 15	ID that applies to the version SPWF04SA and SPWF04SC when this is used with the antennas specified in the Table 8: "Soldering values" . Both versions are modular approved in the meaning defined by FCC
IC	8976C-SPWFS04	IC RSS-247	ID that applies to the version SPWF04SA and SPWF04SC when this is used with the antennas specified in the Table 8: "Soldering values" . Both versions are modular approved in the meaning defined by IC
ETSI	Compliant	ETSI EN 300 328 V1.9.1:2015 EN 301 489-1 V1.9.2: 2011 + EN 301 489-17 V2.2.1:2012 + EN 301 489-1 V1.8.1:2008 EN 60950-1:2006 + A11:2009 + A1:2010 + A12:2011 + A2:2013 EN 62479:2010	ID that applies to the version SPWF04SA and SPWF04SC when this is used with the antennas specified in the Table 8: "Soldering values"

The certifications of the version SPWF04SC that has an integrated U.FL connector applies when the module is connected with the antenna specified in the [Table 8: "Soldering values"](#).

Table 10: Antennas used for certification of SPWF04SC

Product name		
Titanis 2.4 GHz	Article No.	2010B4844-01 (Standard)
		2010B6090-01 (Reverse thread)
	Frequency	2.4 - 2.5 GHz
	Polarization	Linear
	Operating temperature	-40 to +85 degC
	Impedance	50 Ω
	Weight	7.4 g
	Antenna Type	Swivel

10.2.1 FCC and IC

The device SPWF04S has been tested and complies with the FCC part 15 and IC RSS-247 regulations. These limits are designed to provide reasonable protection against harmful interference in approved installations. This equipment generates, uses, and can radiate radio frequency energy and, if not installed and used in accordance with the instructions, may cause harmful interference to radio communications.

However, there is no guarantee that interference will not occur in a particular installation. This device complies with part 15 of the FCC rules. Operation is subject to the following two conditions:

- The device must not cause harmful interference.
- The device must accept any interference received, including interference that may cause undesired operation.

Modifications or changes to this equipment not expressly approved by the party responsible for compliance may render void the user's authority to operate this equipment.

The module has been approved by Industry Canada to operate with the antenna type listed in [Table 10: "Antennas used for certification of SPWF04SC"](#) with the maximum possible gain there indicated. Antenna types not included in [Table 10: "Antennas used for certification of SPWF04SC"](#) and that have a gain greater than the maximum gain indicated for that type in the [Table 11: "Titanis antenna characteristics"](#), are strictly prohibited for use with this module.

Table 11: Titanis antenna characteristics

	Characteristics			Conditions ⁽¹⁾
	Min.	Typ.	Max.	
Peak Gain	4.0 dBi	4.1 dBi	4.4 dBi	Frequency 2.4 – 2.5 GHz, measured in 3D chamber (near field)
Efficiency	80%	85%	90%	
VSWR	1.1:1	1.2:1	1.3:1	Frequency 2.4 – 2.5 GHz, measured in Network Analyzer

Notes:

⁽¹⁾Note all data provided in this table are based on the Antenova reference board.

The safe user distance, for RF exposure, is ≥ 50 mm (in compliance with 447498 D01 General RF Exposure Guidance v06 and RSS-102 Issue 5).

Modular approval, FCC and IC

- FCC ID: S9NSPWFS04
- IC: 8976C-SPWFS04

In accordance with FCC part 15, the modules SPWF04SA and SPWF04SC are listed above as a modular transmitter device.

Labeling instructions

When integrating the SPWF04SA and SPWF04SC into the final product, it must be ensured that the FCC labeling requirements specified below are satisfied. Based on the Public Notice from FCC, the product into which the ST transmitter module is installed must display a label referring to the enclosed module. The label should use wording like the following:

Contains Transmitter Module

- FCC ID: S9NSPWFS04
- IC: 8976C-SPWFS04

Any similar wording that expresses the same meaning may also be used.

10.2.2 CE

This module complies with the following European EMI/EMC and safety directives and standards:

- Radio Spectrum ETSI EN 300 328 V1.9.1:2015
- EMC EN 301 489-1 V1.9.2:2011 + EN 301 489-1 V1.8.1:2008 +
- EN 301 489-17 V2.2.1:2012
- Safety EN 60950-1:2006 + A11:2009 + A1:2010 + A12:2011 + A2:2013
- Health EN 62479:2010

Figure 11: CE Label

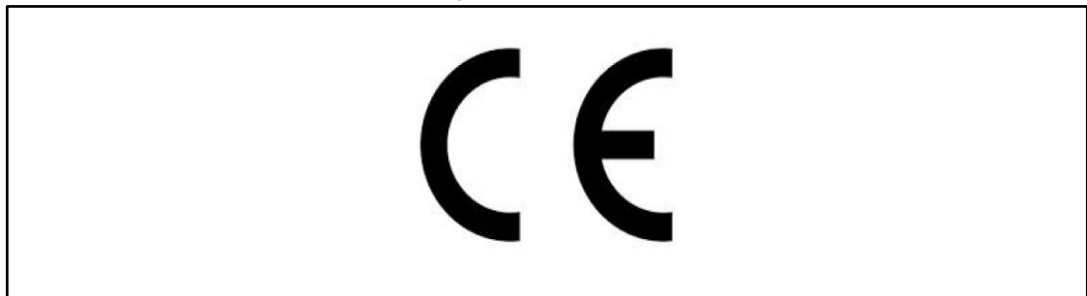

11 Module marking and traceability

The SPWF04Sx top-side contains the following information:

- CE label printed on the shield

Figure 12: SPWF04SA front side

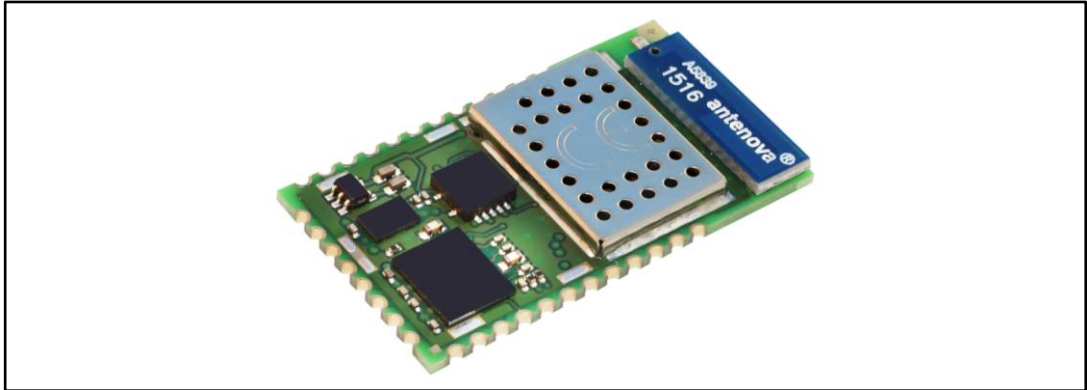

The SPWF04x bottom-side contains the following information:

- Model number indicating the RF module family: SPWF04Sx
- FCC USA certification number: FCC ID: S9NSPWFS04
- IC Canada certification number: IC: 8976C-SPWFS04
- 2D laser data matrix

Figure 13: SPWF04SA bottom side

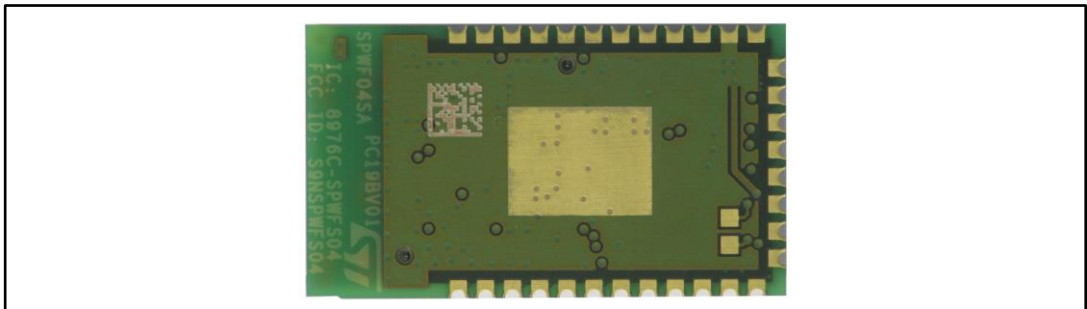

The 2D data matrix laser marked stores a serial number codified in the following format: WW YY K PP NNN, where:

- WW - Week
- YY - Year
- K - Product ID (refer to follows table)
- PP - Internal ST use only
- NNN - Internal ST use only

Table 12: Module product ID

K	Product family identification
<	SPWF04SA
>	SPWF04SC

Every module is completely traceable thanks to the following applied rules:

- Each module bulk package is identified by a bulk ID
- The bulk ID and module 2D data matrix are linked by a reciprocal traceability link
- The module 2D data matrix traces the lot number of any raw material used