



Chipsmall Limited consists of a professional team with an average of over 10 year of expertise in the distribution of electronic components. Based in Hongkong, we have already established firm and mutual-benefit business relationships with customers from,Europe,America and south Asia,supplying obsolete and hard-to-find components to meet their specific needs.

With the principle of "Quality Parts,Customers Priority,Honest Operation,and Considerate Service",our business mainly focus on the distribution of electronic components. Line cards we deal with include Microchip,ALPS,ROHM,Xilinx,Pulse,ON,Everlight and Freescale. Main products comprise IC,Modules,Potentiometer,IC Socket,Relay,Connector.Our parts cover such applications as commercial,industrial, and automotives areas.

We are looking forward to setting up business relationship with you and hope to provide you with the best service and solution. Let us make a better world for our industry!



Contact us

Tel: +86-755-8981 8866 Fax: +86-755-8427 6832

Email & Skype: info@chipsmall.com Web: www.chipsmall.com

Address: A1208, Overseas Decoration Building, #122 Zhenhua RD., Futian, Shenzhen, China





SPX1583

1.5A Ultra Low Dropout Voltage Regulator Fast Response, Adjustable & Fixed

FEATURES

- Low Dropout Voltage 500mV at 1.5A Full Load Current
- Adjustable Output Down to 1.2V from ATX Power Supply
- Fixed Output Voltages of 3.3V, 2.8V, 2.5V, and 1.5V
- Extremely Tight Voltage and Line Regulation
- Standard 5-Terminal Low Cost TO-220 & TO-263

APPLICATIONS

- 3.3V to 2.8V ATX Power Supplies
- 3.3V to 2.9V for Portable PENTIUM™ Processor
- 5V to 3.5V VRE Supply
- High Efficiency “Green” Computer Systems

Now Available in Lead Free Packaging

PRODUCT DESCRIPTION

The SPX1583 is a 1.5A Low Dropout Regulator with extremely low dropout voltage. The adjustable version requires only two external resistors to set the output voltage. The fixed version has a preset output of 3.3V, 2.8V or 2.5V and does not require any external resistors. The SPX1583 features a low dropout of less than 400mV(typ.) and offers fast transient response. **This device is suitable for Pentium applications requiring 2.8V or 2.5V from 3.3V ATX power supplies**, where a low current input voltage 1V greater than the output voltage is needed. With an external sense pin the load regulation is less than 1mV. This device is an excellent choice for the use in powering low voltage microprocessors that require a lower dropout, fast transient response to regulate from 3.3V and 5V supplies. The SPX1583 is also an excellent choice as a post regulator for switching supplies applications.

The SPX1583 offers full protection against over-current faults, reversed input polarity, over temperature operation and positive and negative transient voltage.

The SPX1583 is offered in a 5 pin TO-220 and TO-263 compatible with industry standard 5-terminal regulators. For 7A, 5A and 3A ultra low dropout versions refer to SPX1580, SPX1581 and SPX1582 data sheets respectively.

PIN CONNECTIONS

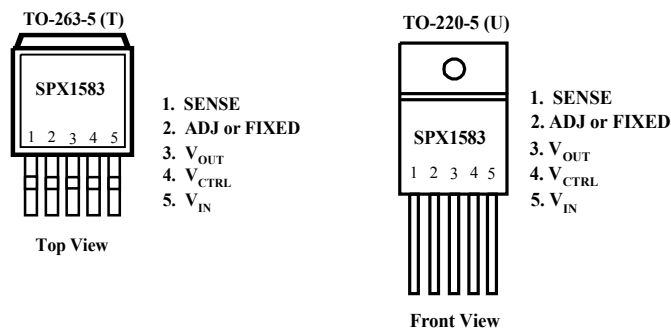

ABSOLUTE MAXIMUM RATINGS

Power Dissipation.....	Internally Limited	Input Supply Voltage	6V
Lead Temp (soldering, 10 seconds).....	300°C	V _{CTRL} Input Voltage	13V
Storage Temperature Range	-65°C to +150°C		
Operating Junction Temperature Range			
SPX1583 Control Section	0°C to +125°C		
SPX1583 Power Transistor	0°C to +150°C		

ELECTRICAL CHARACTERISTICS at V_S=14V, T_A=25°C, I_O=10mA, C₂=100µF, unless otherwise specified. (Note 1) (Boldface applies over full temperature range).

Parameters	Conditions	SPX1583			Units
		Min	Typ	Max	
2.5V Version					
Output Voltage	V _{CTRL} =6.0V to 12V, V _{IN} =3.0V to 5.0V, I _O =10mA I _O =10mA to 1.5A	2.450 2.400	2.500	2.550 2.600	V
2.8V Version					
Output Voltage	V _{CTRL} =6.3V to 12V, V _{IN} =3.3V to 12V, I _O =10mA I _O =10mA to 1.5A	2.744 2.688	2.800	2.856 2.912	V
3.3V Version					
Output Voltage	V _{CTRL} =6.3V to 12V, V _{IN} =3.3V to 12V, I _O =10mA I _O =10mA to 1.5A	3.234 3.168	3.300	3.366 3.432	V
All Voltage Options					
Reference Voltage	V _{CTRL} =2.75V, V _{IN} =2.00V, I _O =10mA V _{CTRL} =2.7V to 12V, V _{IN} =2.05V to 5.5V, I _O =10mA to 1.5A	1.237	1.250	1.263	V
Line Regulation	V _{CTRL} =2.5V to 12V, V _{IN} =1.75V to 5.5V, I _O =10mA V _{ADJ} =0V		1.0	3.0	mV
Load Regulation (Note1)	V _{CTRL} =2.75V, V _{IN} =2.1V, I _O =10mA to 1.5A, V _{ADJ} =0V		1.0	5.0	mV
Dropout Voltage Minimum V _{CTRL} (Note2) (V _{CTRL} - V _{OUT})	V _{ADJ} =0V V _{IN} =2.05V, I _O =1A		1.00	1.15	V
Dropout Voltage Minimum V _{IN} (Note2) (V _{IN} - V _{OUT})	V _{ADJ} =0V V _{IN} =2.75V, I _O =1.5A		0.40	0.50	V
Current Limit	V _{CTRL} =2.75V, V _{IN} =2.05V, dV _O =100mV, V _{ADJ} =0V	1.6			A
Minimum Load Current	V _{CTRL} =5V, V _{IN} =3.3V, V _{ADJ} =0V		5	10	mA
Thermal Regulation	30ms Pulse		0.002	0.02	%W
Ripple Rejection	V _{CTRL} =3.75V, V _{IN} =3.75V, I _O =2.15A, V _{ADJ} =0V T _J =25, V _{RIPPLE} =1Vpp at 120Hz	60	80		dB
Control Pin Current	V _{ADJ} =0V V _{CTRL} =2.75V, V _{IN} =2.05V, I _O =1.5A		60	120	mA
Adjustable Pin Current	V _{CTRL} =2.75V, V _{IN} =2.05V, V _{ADJ} =0V, I _O =10mA		50	90	µA
Thermal Resistance	TO-220-5	Junction to Case (θ _{JC})		3	°C/W
		Junction to Ambient (θ _{JA})		50	°C/W
	TO-263-5	Junction to Case (θ _{JC})		3	°C/W
		Junction to Ambient (θ _{JA})		60	°C/W

The **Bold** specifications applying to the over full operating temperature range.

Note 1: Low duty cycle pulse testing with Kelvin connections is required to order to maintain accurate data.

Note 2: Dropout voltage is defined as the minimum differential between V_{IN} and V_{OUT} or V_{CTRL} and V_{OUT} required to maintain regulation at V_{OUT} 99% Nominal V_{OUT}.

Note 3: V_{REF} is measured across Adjust pin to Sense pin.

PIN DESCRIPTION

1. SENSE = Allows Kelvin sense of V_{OUT} at the load. (Positive side of the reference voltage of the device).
2. ADJ = Negative side of the reference voltage for the device. Adding a small bypass capacitor from the ADJ pin to ground will improve the transient response.
3. V_{OUT} = Power output of the device.
4. V_{CTRL} = Supply pin for the control circuitry of the device. The current flow into this pin will be about 1% of the output current. V_{CTRL} must be between 1.0V and 1.3V greater than the output voltage for the device to regulate.
5. V_{IN} = Output load current is supplied through this pin. V_{IN} must be between 0.1V and 0.8V greater than the output voltage for the device to regulate.

Note that TAB is internally connected to Pin 3.

BLOCK DIAGRAM

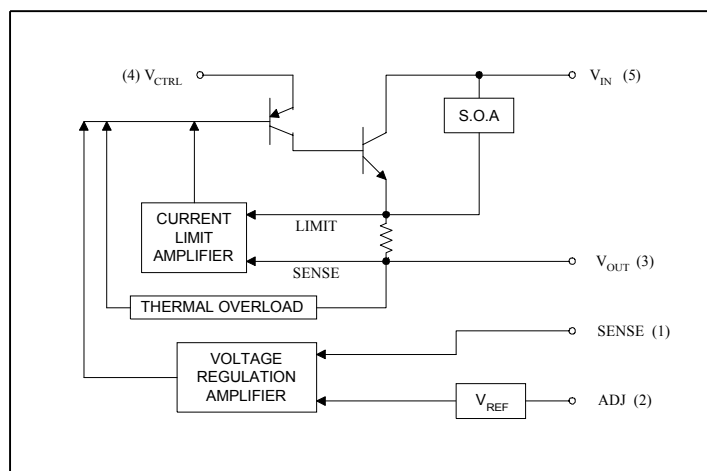

APPLICATIONS NOTES

The SPX1583 is designed as a high performance and low cost solution for application requiring a lower dropout than traditional NPN regulators.

The SPX1583 uses a separate input voltage V_{CTRL} ($V_{CTRL} \geq V_{OUT} + 1.3V$) to minimize the dropout voltage. This allows the 2.5V power for the load to come from a 3.3V system supply. As added benefit this will reduce the heat dissipation, and lower heatsink and cooling fan cost. A typical application would use 5V for V_{in} and 3.3V for V_{CTRL} from a motherboard power supply to provide a nominal 2.5V output. Using the sense pin allows to Kelvin measure the output, reducing resistive-associated errors.

The SPX1583 can power the 2.5V core voltage for microprocessors such as Pentium™, P55C™, AMD5k86™ and K6™ and the IBM PowerPC™ 603EV and 604EV processors.

1.25V reference voltage is being developed between the SENSE pin and the ADJ pin of the SPX1583. Adding two external resistors (see fig 1.) will allow setting the output voltage from 1.25V to 6V. R_1 is chosen so that this current is specified minimum load current of 10mA. R_2 is given by the formula: $V_{OUT} = V_{REF} (1 + R_2/R_1) + I_{ADJ} (R_2)$. The current flowing from the ADJ pin is typically 50μA. This ADJ pin contributes to the final V_{OUT} but is usually neglected. Connecting the sense pin to the top of the resistor divider will improve load regulation.

Lowering Noise

Using the SENSE pin to Kelvin the load will increase accuracy of the output voltage during load regulation. For the fixed voltage devices, adding a capacitor at the GND pin will improve transient response. This capacitor is chosen in the range of 1μF to 0.1μF and will depend on the amount of output capacitance in the system.

*The reduction of heat dissipation is a result of the increase of the regulator efficiency (efficiency = V_{OUT} / V_{IN}).

TYPICAL APPLICATION

Fig. 1 Adjustable Regulator

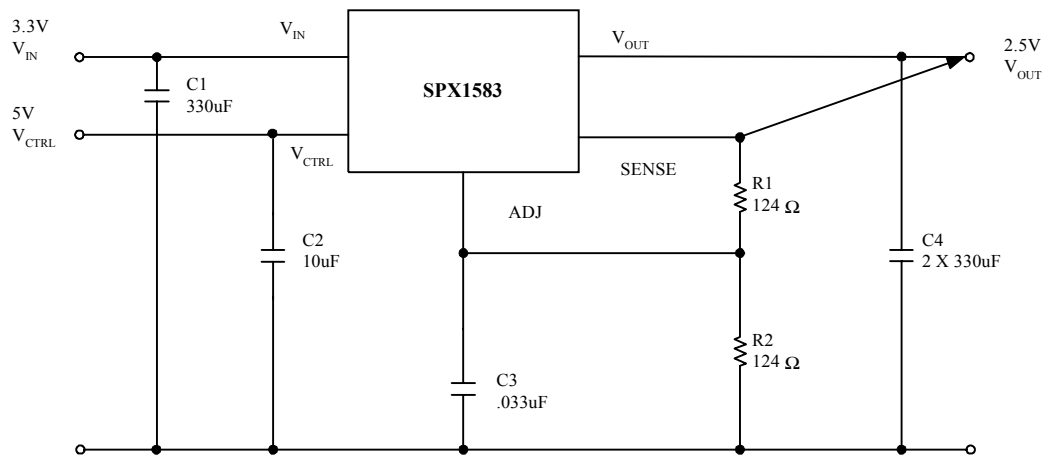

- (1) V_{CTRL} needed when $V_{IN} < 5V$.
- (2) $V_{OUT} = V_{REF} (1 + R2/R1) + I_{ADJ} R2$.
- (3) V_{REF} is measured across adjust to sense.

Fig.2 Typical Fixed Regulator

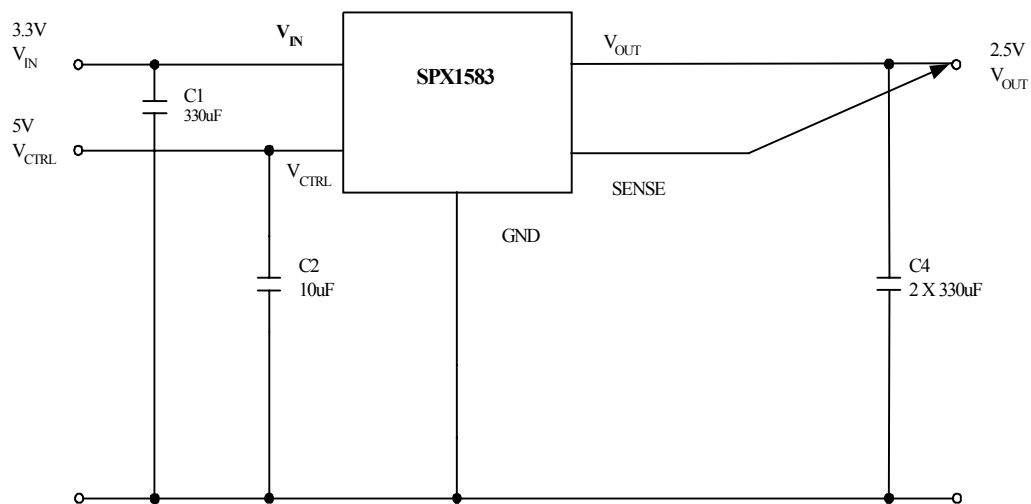

- (1) V_{CTRL} is needed when $V_{IN} < 5V$.

ORDERING INFORMATION

Ordering No.	Precision	Output Voltages	Packages
SPX1583U5	0.6%	Adj	5 Lead TO-220
SPX1583U5-1-5	0.6%	1.5V	5 Lead TO-220
SPX1583U5-2-5	0.6%	2.5V	5 Lead TO-220
SPX1583U5-3-0	0.6%	3.0V	5 Lead TO-220
SPX1583U5-3-3	0.6%	3.3V	5 Lead TO-220
SPX1583T5	0.6%	Adj	5 Lead TO-263
SPX1583T5-1-5	0.6%	1.5V	5 Lead TO-263
SPX1583T5-1-8	0.6%	1.8V	5 Lead TO-263
SPX1583T5-2-5	0.6%	2.5V	5 Lead TO-263
SPX1583T5-2-8	0.6%	2.8V	5 Lead TO-263
SPX1583T5-2-85	0.6%	2.85V	5 Lead TO-263
SPX1583T5-3-0	0.6%	3.0V	5 Lead TO-263
SPX1583T5-3-3	0.6%	3.3V	5 Lead TO-263
SPX1583T5-5-0	0.6%	5.0V	5 Lead TO-263

Available in lead free packaging. To order add "-L" suffix to part number.
Example: SPX1583T5-3-3/TR = standard; SPX1583T5-L-3-3/TR = lead free.
/TR = Tape and Reel
Pack quantity is 500 for TO-263.



ANALOG EXCELLENCE

Sipex Corporation

Headquarters and Main Offices:
233 South Hillview Drive
Milpitas, CA 95035
TEL: (408) 935-7600
FAX: (408) 934-7500

Sipex Corporation reserves the right to make changes to any products described herein. Sipex does not assume any liability arising out of the application or use of any product or circuit described hereing; neither does it convey any license under its patent rights nor the rights of others.