



Chipsmall Limited consists of a professional team with an average of over 10 year of expertise in the distribution of electronic components. Based in Hongkong, we have already established firm and mutual-benefit business relationships with customers from,Europe,America and south Asia,supplying obsolete and hard-to-find components to meet their specific needs.

With the principle of “Quality Parts,Customers Priority,Honest Operation,and Considerate Service”,our business mainly focus on the distribution of electronic components. Line cards we deal with include Microchip,ALPS,ROHM,Xilinx,Pulse,ON,Everlight and Freescale. Main products comprise IC,Modules,Potentiometer,IC Socket,Relay,Connector.Our parts cover such applications as commercial,industrial, and automotives areas.

We are looking forward to setting up business relationship with you and hope to provide you with the best service and solution. Let us make a better world for our industry!



## Contact us

Tel: +86-755-8981 8866 Fax: +86-755-8427 6832

Email & Skype: info@chipsmall.com Web: www.chipsmall.com

Address: A1208, Overseas Decoration Building, #122 Zhenhua RD., Futian, Shenzhen, China



## Precision Adjustable Shunt Regulator

### FEATURES

- Trimmed Bandgap to 0.5% and 1.0%
- Wide Operating Current 1mA to 100mA
- Extended Temp. Range: 0°C to 105°C
- Low Temperature Coefficient 30 ppm/°C
- Offered in 3 Pin SOT-23 (M)
- Replacement for TL431, AS2431
- Low Noise Output

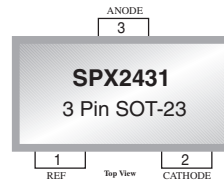

*Now Available in Lead Free Packaging*

### APPLICATIONS

- Battery Operating Equipment
- Adjustable Supplies
- Switching Power Supplies
- Error Amplifiers
- Single Supply Amplifier
- Monitors / VCRs / TVs
- Personal Computers

### DESCRIPTION

The SPX2431 is a 3-terminal adjustable shunt voltage regulator providing a highly accurate bandgap reference. The SPX2431 acts as an open-loop error amplifier with a 2.5V temperature compensation reference. The SPX2431's thermal stability, wide operating current (100mA) and temperature range (0°C to 105°C) makes it suitable for a variety of applications that require a low cost, high performance solution. SPX2431A tolerance of 0.5% is proven to be sufficient to overcome all of the other errors in the system to virtually eliminate the need for trimming in the power supply manufacturer's assembly line and contribute a significant cost savings.

The output voltage may be adjusted to any value between  $V_{REF}$  and 20 volts with two external resistors. In the standard shunt configuration, the combination of a low temperature coefficient, sharp turn on characteristics, low output impedance, and programmable output voltage makes this precision reference an excellent error amplifier. The SPX2431 is available in SOT-23-3 package.

### FUNCTIONAL DIAGRAM

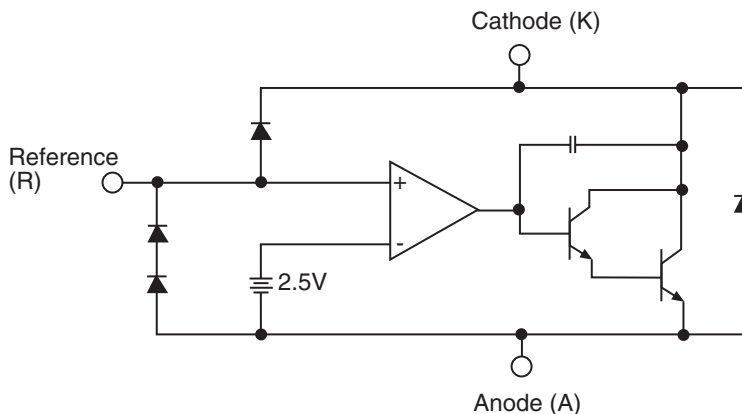

## ABSOLUTE MAXIMUM RATINGS

Cathode-Anode Reverse Breakdown $V_{KA}$ .....	20V
Anode-Cathode Forward Current, (<10ms) $I_{AK}$ .....	1A
Operating Cathode Current $I_{KA}$ .....	100mA
Reference Input Current $I_{REF}$ .....	1.0mA
Continuous Power Dissipation at 25°C $P_D$ SOT-23 .....	200 mW
Junction Temperature $T_J$ .....	150 °C
Storage Temperature $T_{STG}$ .....	-65 to 150 °C

**NOTE:** Stresses greater than those listed under ABSOLUTE MAXIMUM RATINGS may cause permanent damage to the device. This is a stress rating only and functional operation of the device at these or any other conditions above those indicated in the operational sections of this specification is not implied. Exposure to absolute maximum rating conditions for extended periods may affect reliability.

## RECOMMENDED CONDITIONS

PARAMETER	SYMBOL	RATING	UNIT
Cathode Voltage	$V_{KA}$	$V_{REF}$ to 20	V
Cathode Current	$I_K$	10	mA

## TYPICAL THERMAL RESISTANCES

PACKAGE	$\theta_{JA}$	$\theta_{JC}$	TYPICAL DERATING
SOT-23	575°C/W	150°C/W	1.7 mW/°C

Typical deratings of the thermal resistances are given for ambient temperature >25°.

## ELECTRICAL CHARACTERISTICS

Electrical characteristics at 25°C  $I_K = 10\text{mA}$   $V_K = V_{REF}$ , unless otherwise specified.

PARAMETER	SYMBOL	FIGURE	CONDITIONS	MIN	TYP	MAX	MIN	TYP	MAX	UNITS
				SPX2431A			SPX2431			
Reference Voltage	$V_{REF}$	2	$T_J = 0^\circ\text{C to } 105^\circ\text{C}$	2.487	2.500	2.513	2.474	2.500	2.526	V
		2		2.480		2.520	2.460		2.540	V
$\Delta V_{REF}$ with Temp.*	TC	2			0.07	0.20		0.07	0.20	mV/°C
Ratio of Change in $V_{REF}$ to Cathode Voltage	$\frac{\Delta V_{REF}}{\Delta V_K}$	3	$V_{REF}$ to 10V 10V to 20V	-2.7	-1.01	0.3	-2.7	-1.01	0.3	mV/V
				-2.0	-0.4		-2.0	-0.4		
Reference Input Current	$I_{REF}$	3			0.7	4.0		0.7	4.0	μA
$I_{REF}$ Temp Deviation	$\Delta I_{REF}$	3	$T_J = 0^\circ\text{C to } 105^\circ\text{C}$		0.4	1.2		0.4	1.2	μA
Min $I_K$ for Regulation	$I_{K(MIN)}$	2			0.4	1.0		0.4	1.0	mA
Off State Leakage	$I_{K(OFF)}$	4	$V_{REF} = 0\text{V},$ $V_{KA} = 20\text{V}$		0.04			0.04	500	nA
Dynamic Output Impedance	$Z_{KA}$	2	$f_z \leq 1\text{kHz}$ $I_K = 1$ to 100mA		0.15	0.5		0.15	0.5	Ω

## CALCULATING AVERAGE TEMPERATURE COEFFICIENT (TC)

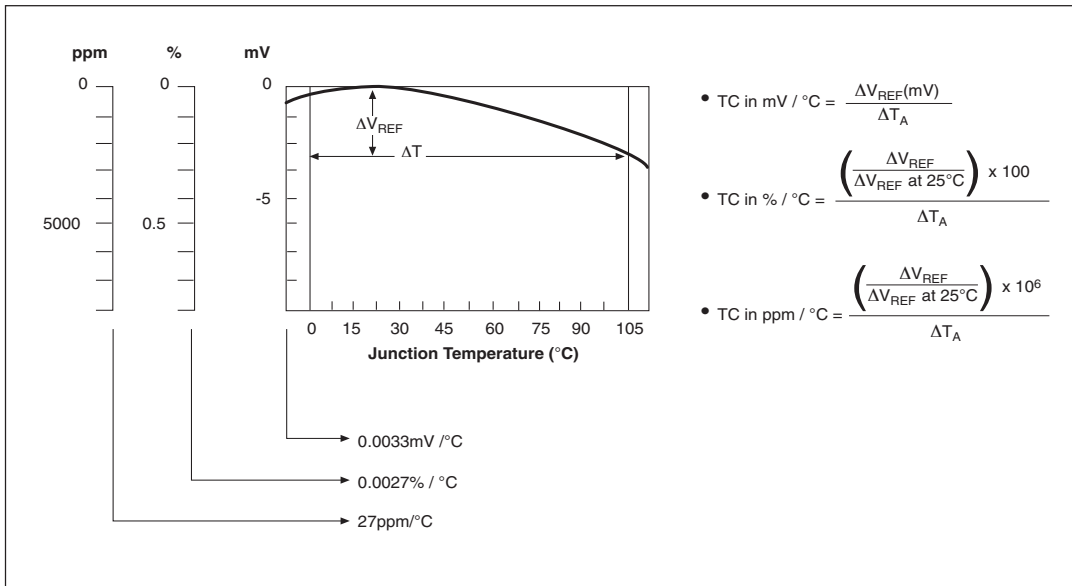

Figure 1.  $V_{REF}$  VS Temperature

## TEST CIRCUITS

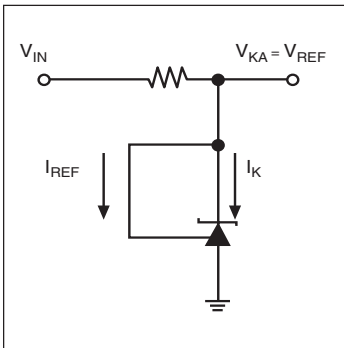

Figure 2. Test Circuit for  $V_{KA} = V_{REF}$

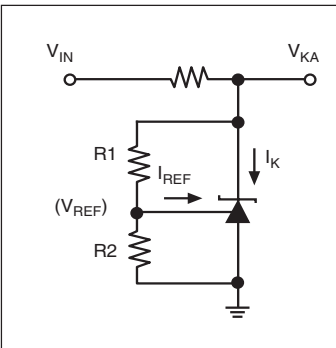

Figure 3. Test Circuit for  $V_{KA} > V_{REF}$

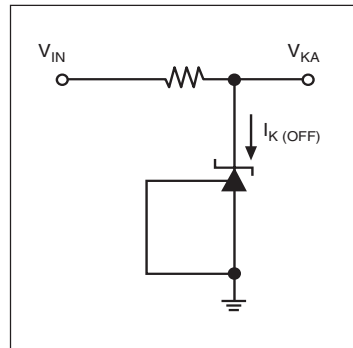

Figure 4. Test Circuit for  $I_{KOFF}$

# TYPICAL PERFORMANCE CHARACTERISTICS

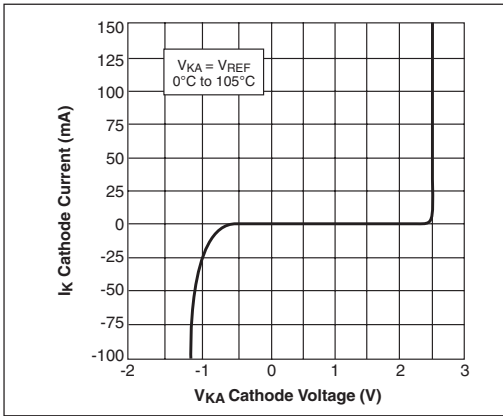

Figure 5. High Current Operating Characteristics

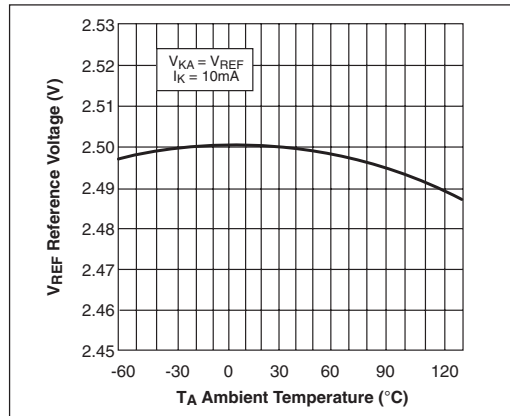

Figure 6. Reference Voltage VS Ambient Temperature

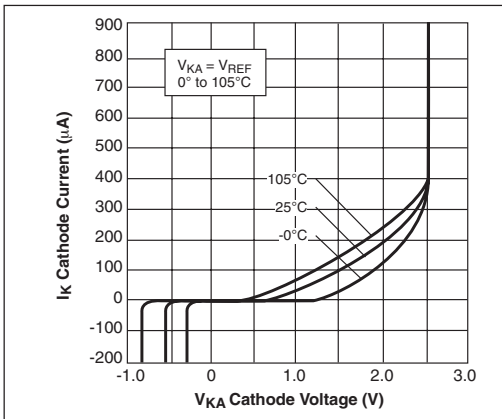

Figure 7. Low Current Operating Characteristics

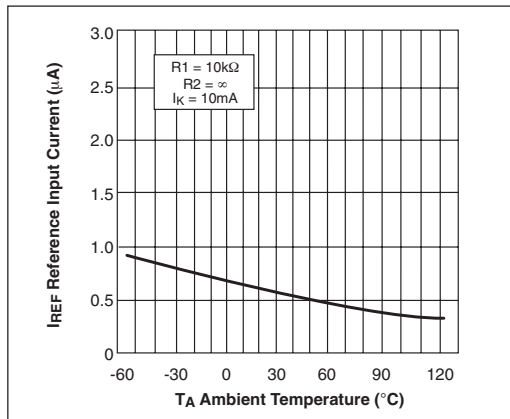

Figure 8. Reference Input Current VS Ambient Temperature

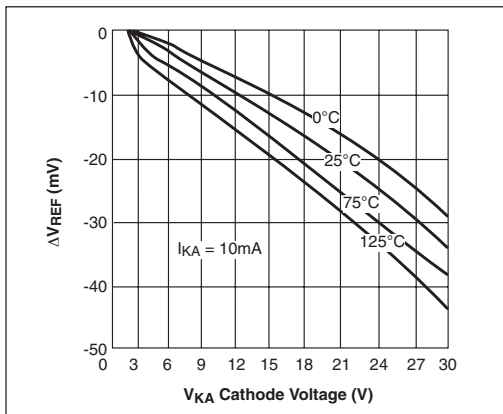

Figure 9. Reference Voltage Line Regulation VS Cathode Voltage and  $T_{AMBIENT}$

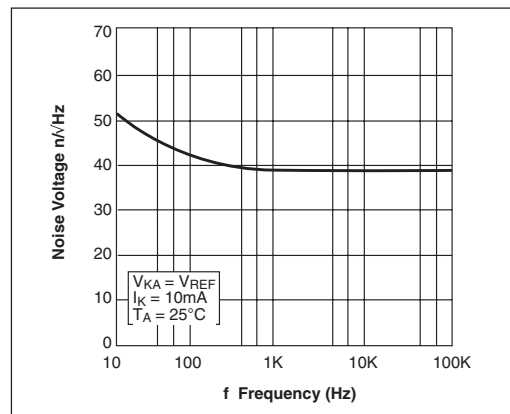

Figure 10. Noise Voltage VS Frequency

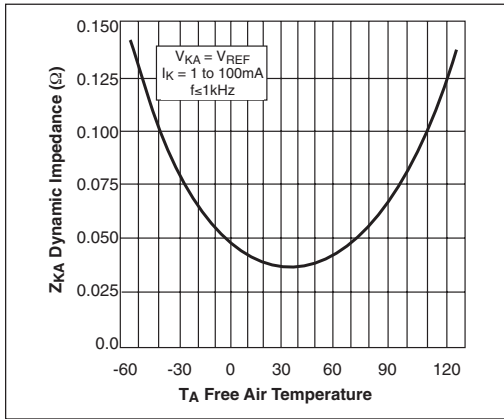

Figure 11. Low Frequency Dynamic Output Impedance VS  $T_{AMBIENT}$

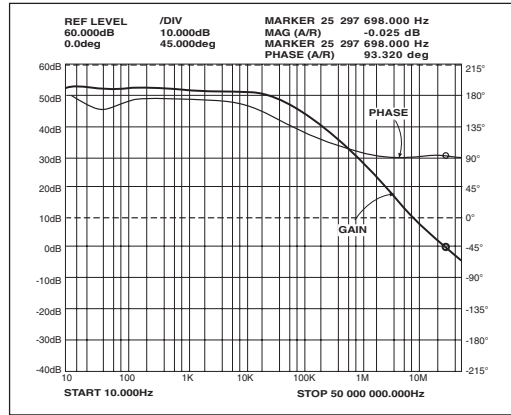

Figure 12. Small Signal Gain and Phase VS Frequency;  $I_K = 10mA$ ,  $T_A = 25^\circ C$

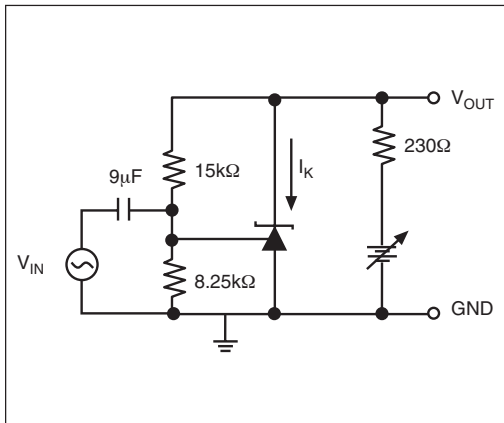

Figure 13. Test Circuit for Gain and Phase Frequency Response

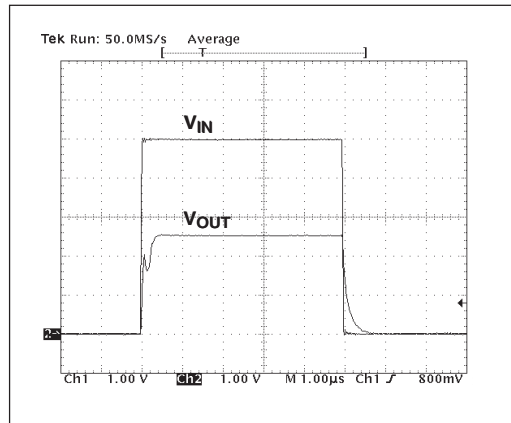

Figure 14. Frequency = 100kHz,  $I_K = 10mA$ ,  $T_A = 25^\circ C$

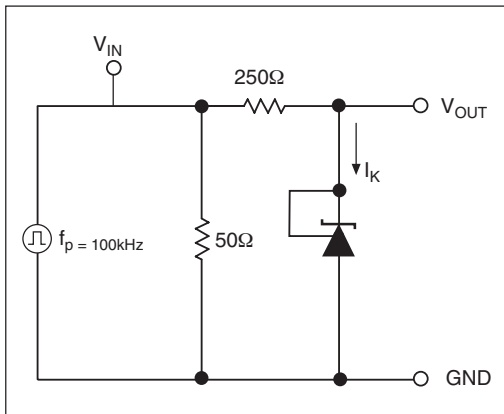

Figure 15. Test Circuit for Pulse Response

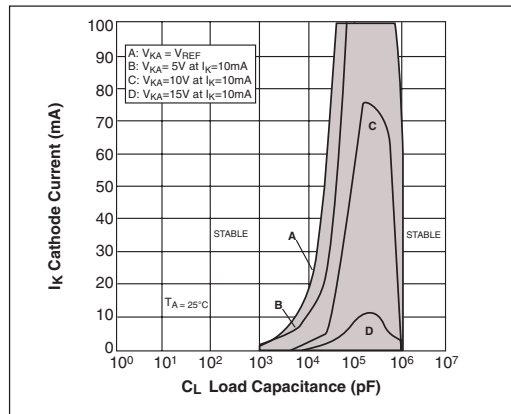

Figure 16. Stability Boundary Conditions

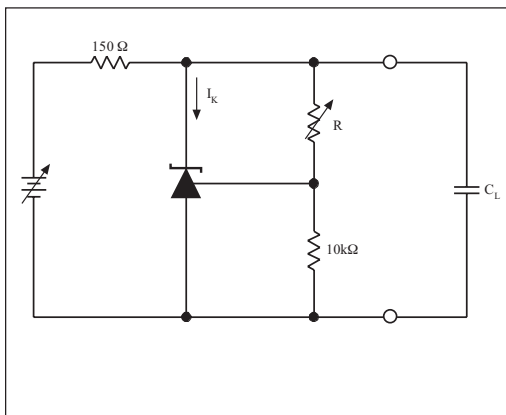

Figure 17. Test Circuit for Stability

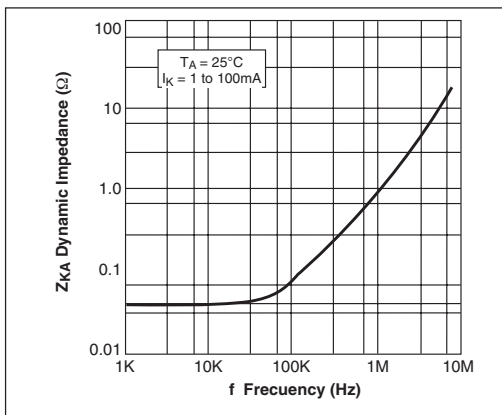

Figure 18. Dynamic Output Impedance  $T_A = 25^\circ\text{C}$ ,  $I_k = 1 \text{ to } 100\text{mA}$

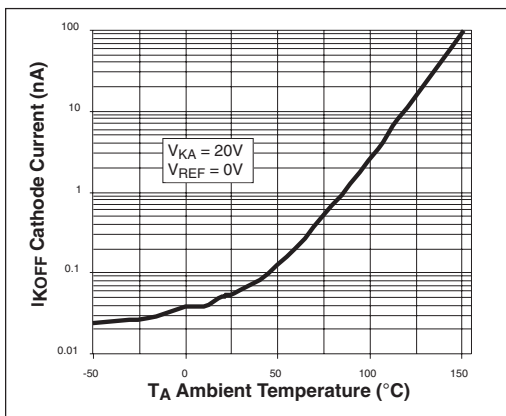

Figure 19. Off State Leakage

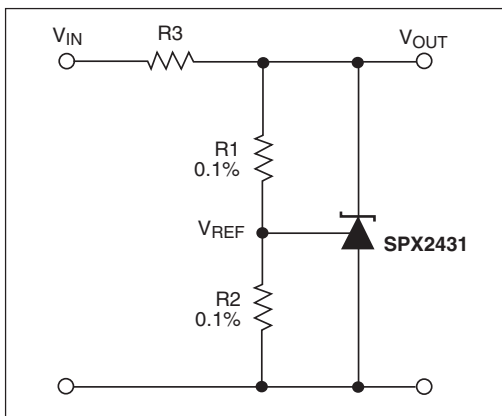

Figure 20. Shunt Regulator  $V_{OUT} = (1+R1/R2)V_{REF}$

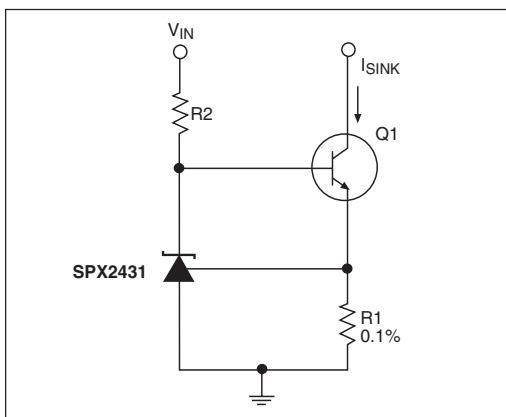

Figure 21. Constant Current Sink,  $I_{SINK} = V_{REF}/R1$

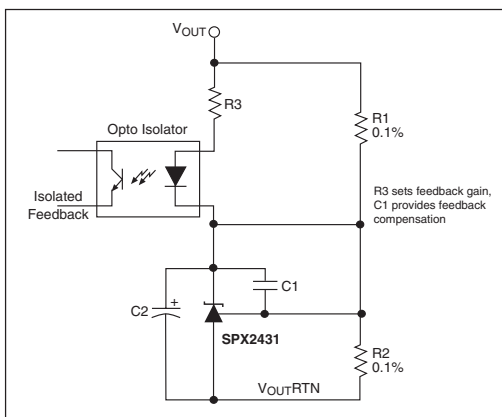

Figure 22. Reference Amplifier for Isolated Feedback in Off-Line DC-DC Converters

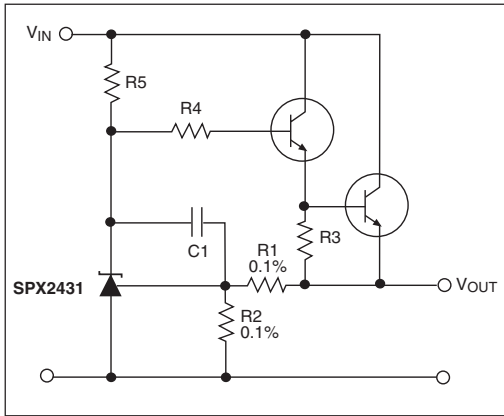

Figure 23. Precision High Current Series Regulator  
 $V_{OUT} = (1+R1/R2)V_{REF}$

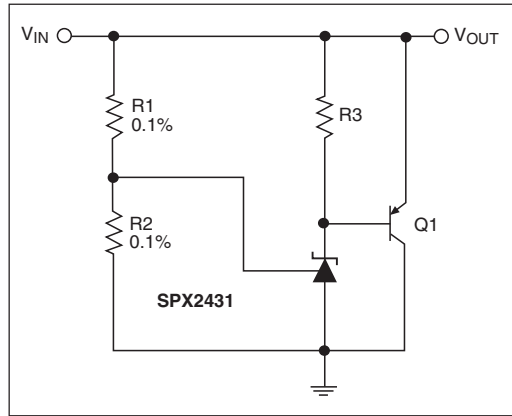

Figure 24. High Current Shunt Regulator  
 $V_{OUT} = (1+R1/R2)V_{REF}$

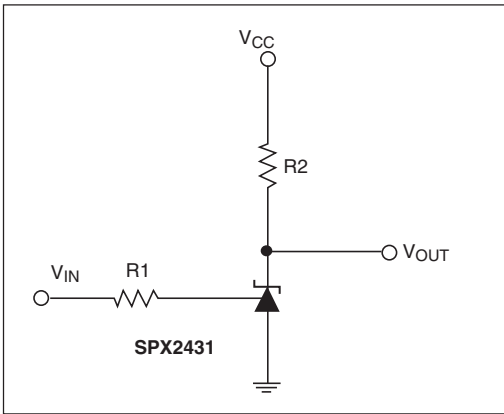
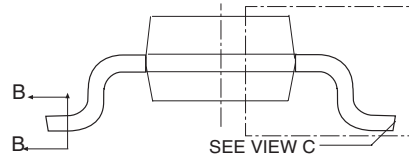
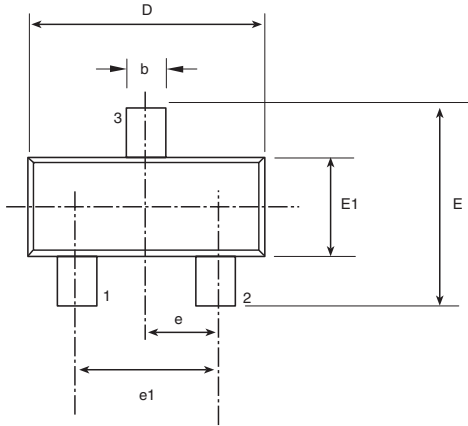

Figure 25. Single Supply Comparator with Temperature Compensated Threshold.  $V_{IN}$  Threshold = 2.5V

\* Resistor values are chosen such that the effect to  $I_{REF}$  is negligible.





VIEW A-A

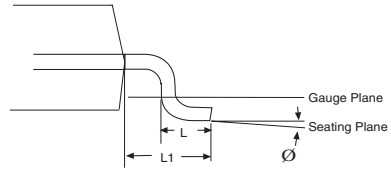

VIEW C

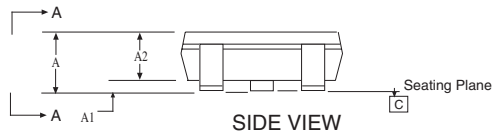

SIDE VIEW

3 Pin SOT-23 JEDEC TO-236 (AB) Variation			
SYMBOL	MIN	NOM	MAX
A	0.89	-	1.12
A1	0.01	-	0.1
A2	0.88	0.95	1.02
b	0.3	-	0.5
c	0.08	-	0.2
D	2.8	2.9	3.04
e	0.95 BSC		
e1	1.90 BSC		
E	0.95	-	2.64
E1	1.2	1.3	1.4
L	0.4	0.5	0.6
L1	0.54 REF		
$\varnothing$	0°	-	8°

Note: Dimensions in (mm)

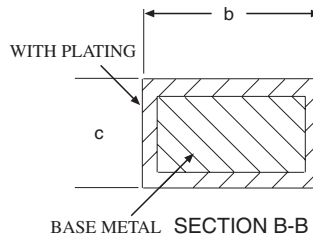

---

**ORDERING INFORMATION**

<b>PART NUMBER</b>	<b>ACC</b>	<b>OUTPUT VOLTAGE</b>	<b>PACKAGES</b>
SPX2431AM .....	0.5% .....	2.5V .....	3 Pin SOT-23
SPX2431AM/TR .....	0.5% .....	2.5V .....	3 Pin SOT-23
SPX2431M .....	1.0% .....	2.5V .....	3 Pin SOT-23
SPX2431M/TR .....	1.0% .....	2.5V .....	3 Pin SOT-23

/TR = Tape and Reel

Pack quantity is 2,500 for SOT-23.

Available in lead free packaging. To order add "-L" suffix to part number.

Example: SPX2431AM/TR = standard; SPX2431AM-L/TR = lead free

---

 [CLICK HERE TO ORDER SAMPLES](#) 



ANALOG EXCELLENCE

**Sipex Corporation**

**Headquarters and  
Sales Office**

22 Linnell Circle  
Billerica, MA 01821  
TEL: (978) 667-8700  
FAX: (978) 670-9001  
e-mail: sales@sipex.com

Sipex Corporation reserves the right to make changes to any products described herein. Sipex does not assume any liability arising out of the application or use of any product or circuit described herein; neither does it convey any license under its patent rights nor the rights of others.