



Chipsmall Limited consists of a professional team with an average of over 10 year of expertise in the distribution of electronic components. Based in Hongkong, we have already established firm and mutual-benefit business relationships with customers from,Europe,America and south Asia,supplying obsolete and hard-to-find components to meet their specific needs.

With the principle of “Quality Parts,Customers Priority,Honest Operation,and Considerate Service”,our business mainly focus on the distribution of electronic components. Line cards we deal with include Microchip,ALPS,ROHM,Xilinx,Pulse,ON,Everlight and Freescale. Main products comprise IC,Modules,Potentiometer,IC Socket,Relay,Connector.Our parts cover such applications as commercial,industrial, and automotives areas.

We are looking forward to setting up business relationship with you and hope to provide you with the best service and solution. Let us make a better world for our industry!



Contact us

Tel: +86-755-8981 8866 Fax: +86-755-8427 6832

Email & Skype: info@chipsmall.com Web: www.chipsmall.com

Address: A1208, Overseas Decoration Building, #122 Zhenhua RD., Futian, Shenzhen, China



Micropower Voltage Reference

FEATURES

- Trimmed Bandgap 1% and 2%
- Wide Operating Current 20 μ A to 20mA
- Extended Temperature Range ... -40°C to +85°C
- Dynamic Impedance 1 Ω max
- Offered in SOT-23, TO-92, SOIC, and SOT-89
- Improved Replacement for LM185/285/385-2.5V, AS385-2.5
- Temp Co 140ppm/°C

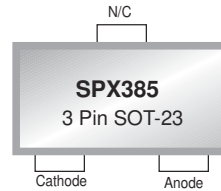

Now Available in Lead Free Packaging

Refer to page 4 for pinouts.

APPLICATIONS

- | | |
|--|--|
| <ul style="list-style-type: none"> ■ Battery Operating Equipment ■ Adjustable Supplies ■ Switching Power Supplies | <ul style="list-style-type: none"> ■ Error Amplifiers ■ Single Supply Amplifier ■ Monitors / VCR / TV ■ Personal Computers |
|--|--|

DESCRIPTION

The SPX385-2.5 is a micropower 2-terminal band-gap voltage reference with a very wide operating current range from 20 μ A to 20mA that provides a stable voltage. The high stability of this device is primarily the result of the low temperature coefficient Thin Film Resistor process and Laser Trimming of the output voltage at the wafer level.

The SPX385-2.5 is available in a SOT-23, TO-92, SOIC-8 and SOT-89 package with an operating temperature range of -40°C to 85°C. A 1.2 and 5 volt device is also available - SPX385-1.2 and SPX385-5.

BLOCK DIAGRAM

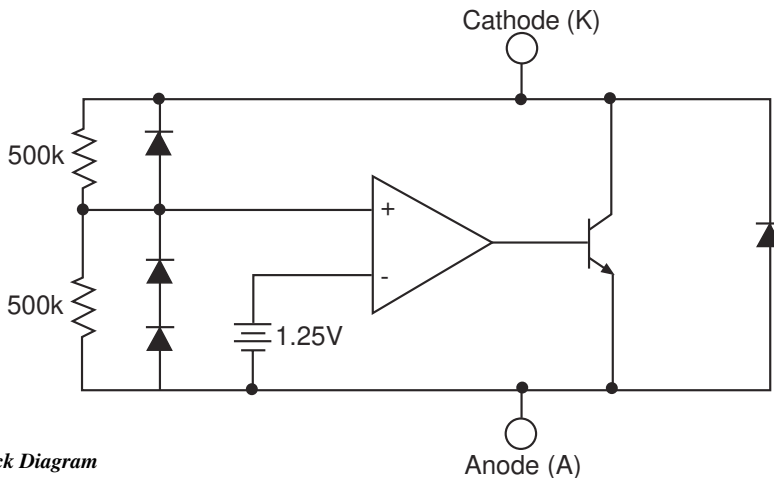

Figure 1: Block Diagram

ABSOLUTE MAXIMUM RATINGS

Stresses greater than those listed under ABSOLUTE MAXIMUM RATINGS may cause permanent damage to the device. This is a stress rating only and functional operation of the device at these or any other conditions above those indicated in the operational sections of this specification is not implied. Exposure to absolute maximum rating conditions for extended periods may affect reliability.

Reverse Current (I_{KA})	30mA
Forward Current (I_{AK})	10mA
Operating Temperature Range (T_A)	-40 to +85°C
Junction Temperature (T_J)	150°C
Storage Temperature (T_{STG})	- 65 to 150°C
Lead Temperature (Soldering 10 sec.), T_L	300°C

TYPICAL THERMAL RESISTANCES

PACKAGE	θ_{JA}	θ_{JC}	TYPICAL DERATING
TO-92	160°C/W	80°C/W	6.3 mW/°C
SOT-23	575°C/W	150°C/W	1.7 mW/°C
SOIC-8	175°C/W	45°C/W	5.7 mW/°C
SOT-89	110°C/W	8°C/W	9.1 mW/°C

Typical deratings of the thermal resistances are given for ambient temperature >25°.

ELECTRICAL CHARACTERISTICS

$I_{IN} = 100\mu A$, $T_A = 25^\circ C$, unless otherwise specified.

PARAMETER	CONDITIONS	SPX385A-2.5			SPX385-2.5			UNIT
		MIN.	TYP.	MAX	MIN.	TYP.	MAX.	
Reference Voltage		2.475	2.500	2.525	2.450	2.500	2.550	V
Dynamic Output Impedance	F = 20Hz $I_R = 100\mu A$		0.6	1.0		0.6	1.0	Ω
Reference Voltage Change with I_R	$20\mu A \leq I_R \leq 20mA$		10	20		10	20	mV
Temperature Coefficient	Note 1		80	140		80	140	ppm/°C
Minimum Operating Current			15	20		15	20	μA
Output Wideband Noise	$10Hz \leq f \leq 10kHz$		120			120		μV_{rms}
Long Term Stability	T=1000Hr; $T_A = 25^\circ C \pm 0.1^\circ C$		60			60		ppm
Operating Temperature		-40		+85	-40		+85	°C

Note 1. Three-point measurement guarantees the error band over the specified temperature range.

*CALCULATING AVERAGE TEMPERATURE COEFFICIENT (TC)

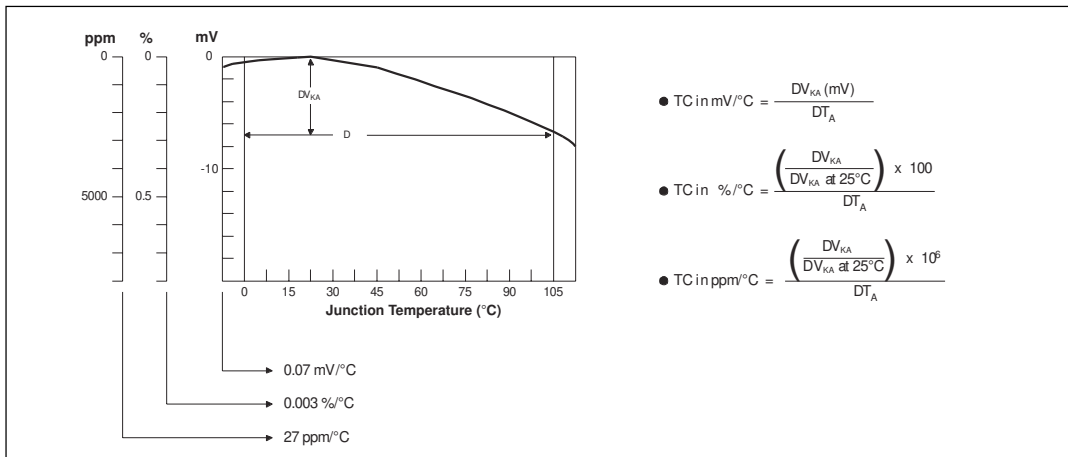

Figure 2. V_{KA} vs. Temperature

TYPICAL PERFORMANCE CHARACTERISTICS

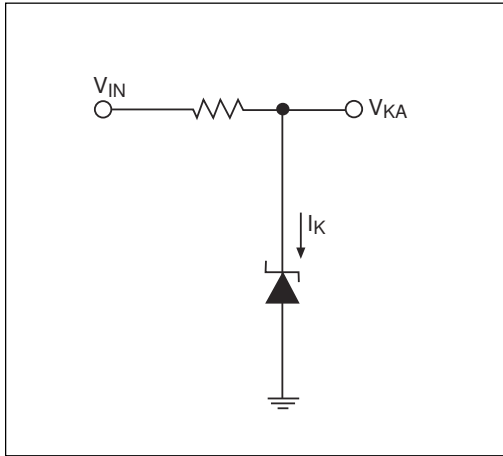

Figure 3. Test Circuit

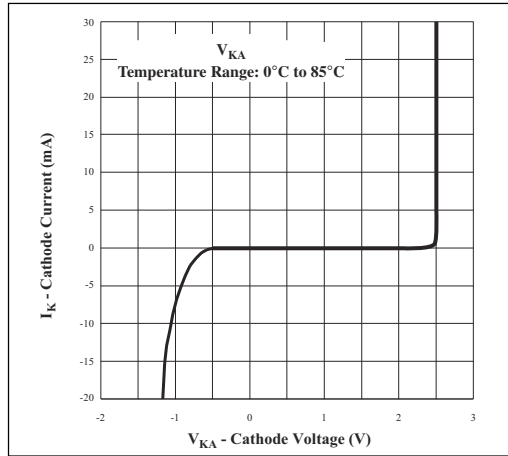

Figure 4. High Current Operating Characteristics

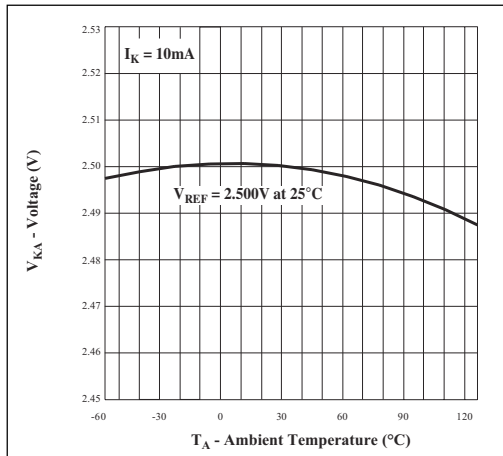

Figure 5. Reference Voltage vs. Ambient Temperature

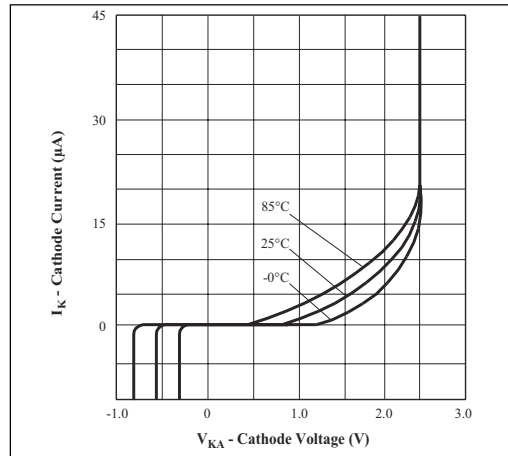

Figure 6. Low Current Operating Characteristics

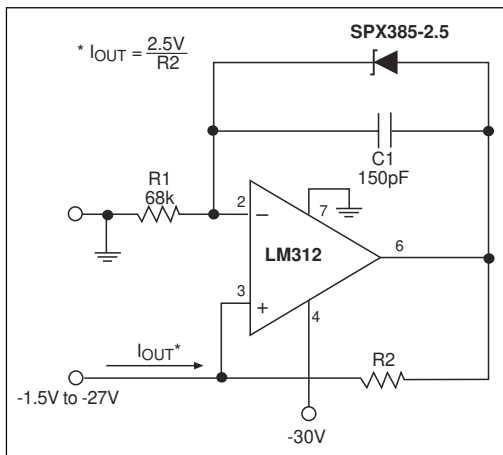

Figure 7a. Precision 1µA to 1mA Current Sink

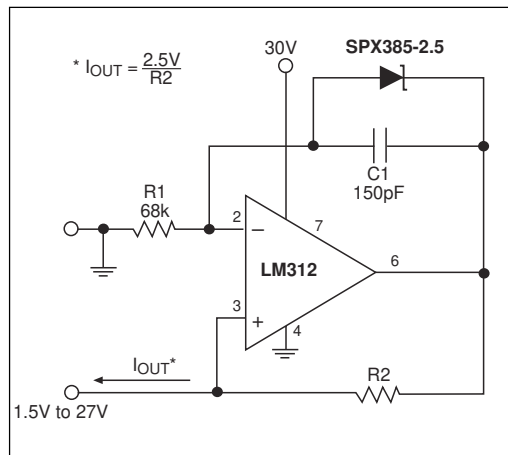

Figure 7b. Precision 1µA to 1mA Current Source

TYPICAL PERFORMANCE CHARACTERISTICS

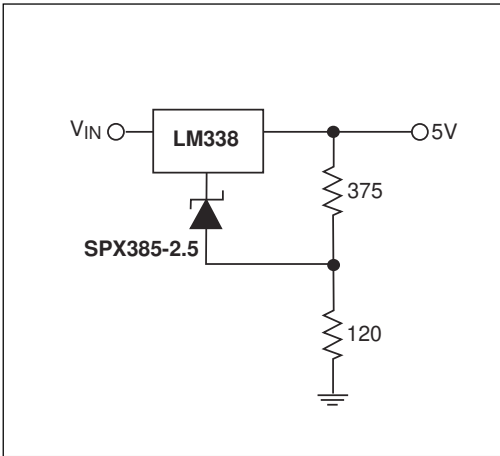

Figure 8. Improving Regulation of Adjustable Regulators

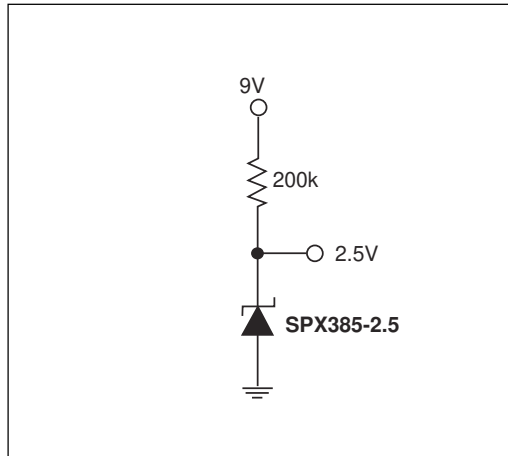

Figure 9. Micropower Reference from 9V Battery

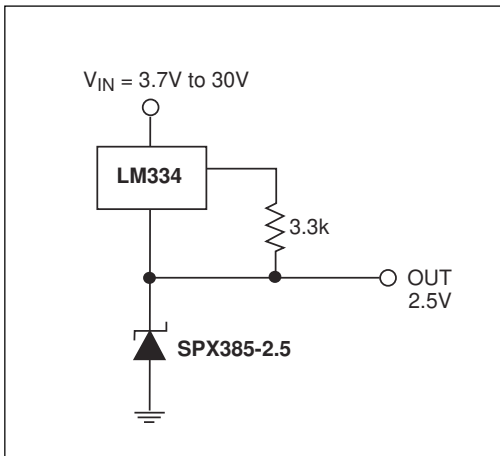

Figure 10. Wide Input Range Reference

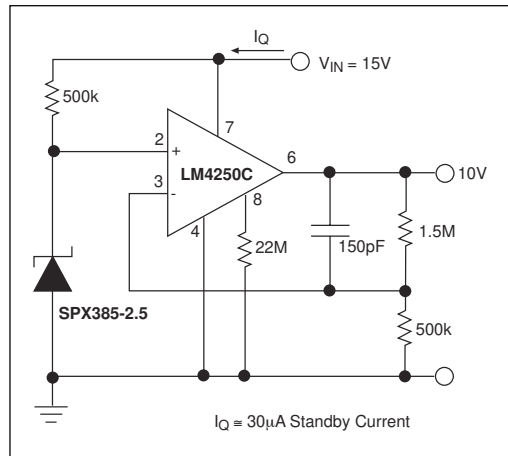
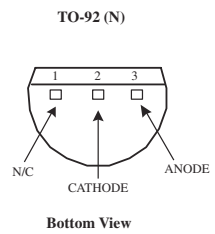
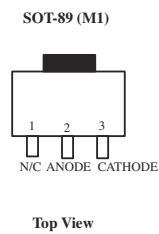
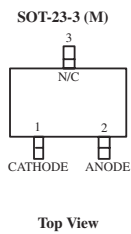
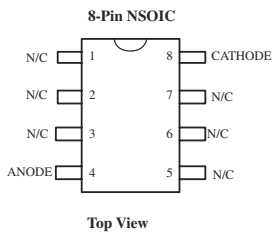
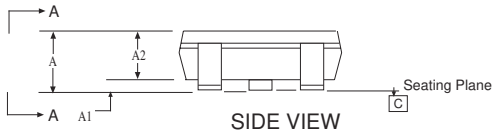
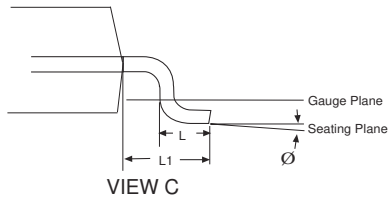
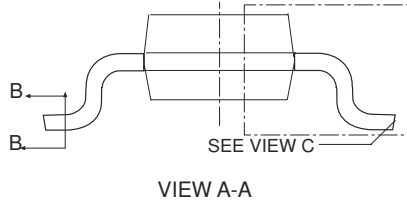
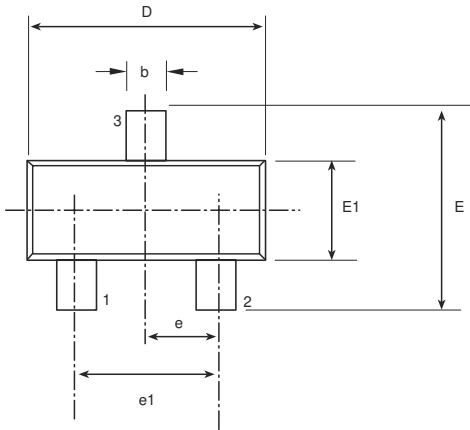

Figure 11. Precision Micropower 10V Reference

PACKAGE PINOUTS



PACKAGE: 3 PIN SOT-23



3 Pin SOT-23 JEDEC TO-236 (AB) Variation			
SYMBOL	MIN	NOM	MAX
A	0.89	-	1.12
A1	0.01	-	0.1
A2	0.88	0.95	1.02
b	0.3	-	0.5
c	0.08	-	0.2
D	2.8	2.9	3.04
e	0.95 BSC		
e1	1.90 BSC		
E	0.95	-	2.64
E1	1.2	1.3	1.4
L	0.4	0.5	0.6
L1	0.54 REF		
Ø	0°	-	8°

Note: Dimensions in (mm)

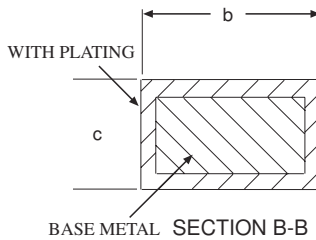

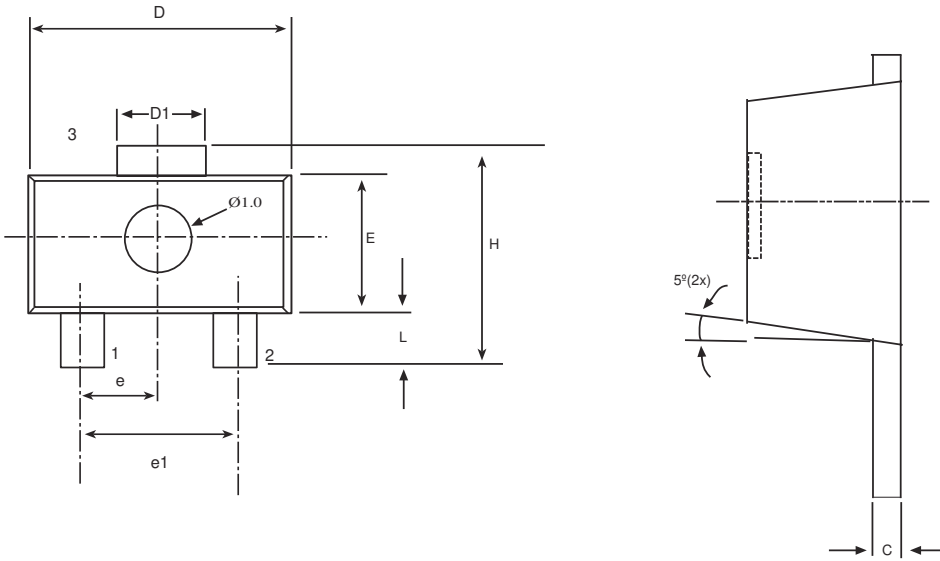

3 Pin SOT-89			
SYMBOL	MIN	NOM	MAX
b	0.36	0.42	0.48
L	0.8	-	1.2
b1	0.41	0.47	0.53
C	0.38	0.4	0.43
D	4.4	4.5	4.6
D1	1.4	1.6	1.75
H	3.94	-	4.25
E	2.4	2.5	2.6
e	1.45	1.5	1.55
e1	2.9	3	3.1

Note: Dimensions in (mm)

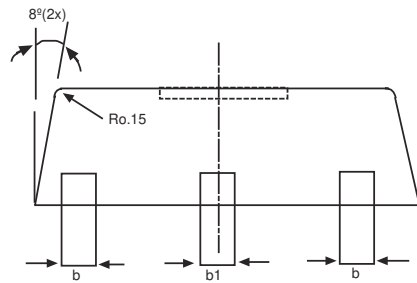

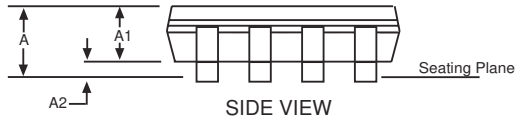
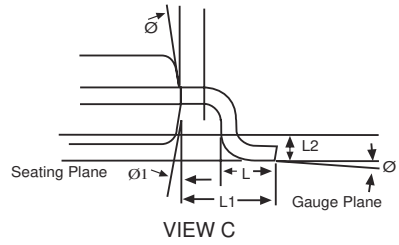
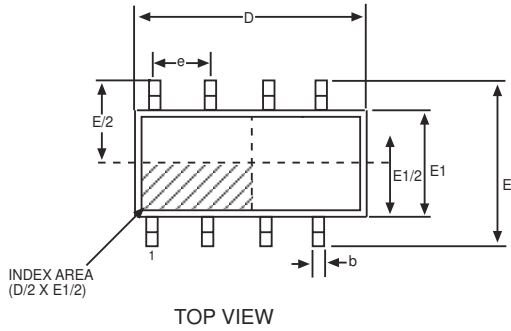

8 Pin NSOIC JEDEC MO-012 (AA) Variation			
SYMBOL	MIN	NOM	MAX
A	1.35	-	1.75
A1	0.1	-	0.25
A2	1.25	-	1.65
b	0.31	-	0.51
c	0.17	-	0.24
D	4.90 BSC		
E	6.00 BSC		
E1	3.90 BSC		
e	1.27 BSC		
L	0.4	-	1.27
L1	1.04 REF		
L2	0.25 BSC		
φ	0°	-	8°
φ1	5°	-	15°

Note: Dimensions in (mm)

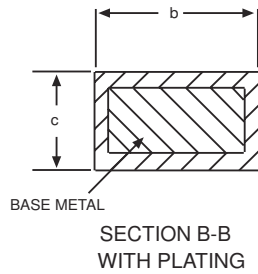
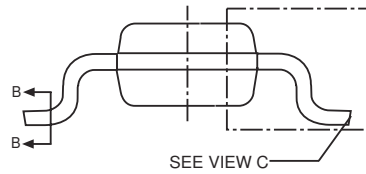

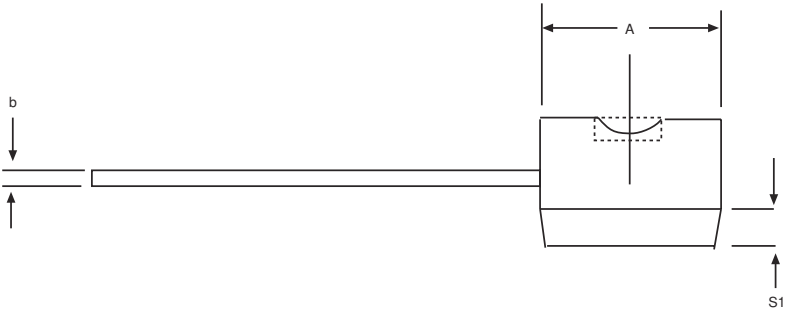
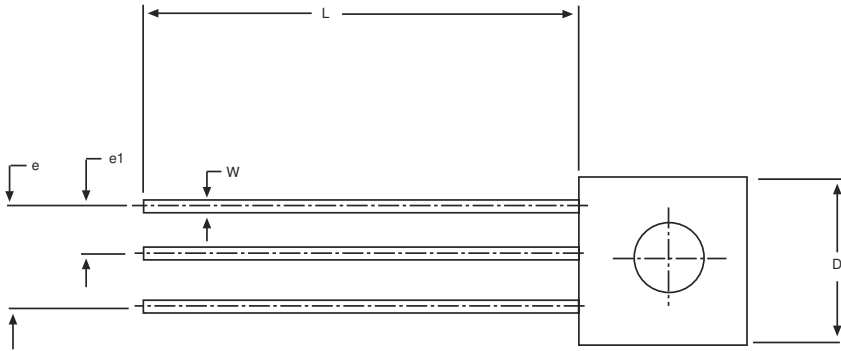

3 Pin TO-92			
SYMBOL	MIN	NOM	MAX
A	0.17	-	0.195
b	0.014	-	0.02
E	0.13	-	0.155
e	0.95	-	0.105
e1	0.045	-	0.055
L	0.5	-	0.61
R	0.085	-	0.095
S1	0.045	-	0.06
W	0.016	-	0.022
D	0.175	-	0.195
a	4°	-	6°

Note: Dimensions in (inches)

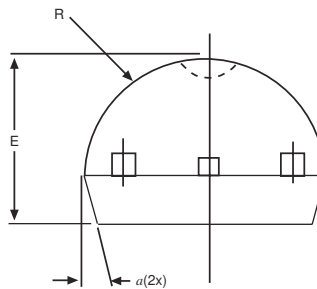

Part Number	Accuracy	Output Voltage	Package Type
SPX385AM-2.5	1.0%	2.5V	3-Pin SOT-23
SPX385AM-2.5/TR	1.0%	2.5V	3-Pin SOT-23
SPX385AM1-2.5	1.0%	2.5V	3-Pin SOT-89
SPX385AM1-2.5/TR	1.0%	2.5V	3-Pin SOT-89
SPX385AS-2.5	1.0%	2.5V	8-Pin NSOIC
SPX385AS-2.5/TR	1.0%	2.5V	8-Pin NSOIC
SPX385AN-2.5	1.0%	2.5V	3-Pin TO-92
SPX385AN-2.5/TR	1.0%	2.5V	3-Pin TO-92
SPX385M-2.5	2.0%	2.5V	3-Pin SOT-23
SPX385M-2.5/TR	2.0%	2.5V	3-Pin SOT-23
SPX385M1-2.5	2.0%	2.5V	3-Pin SOT-89
SPX385M1-2.5/TR	2.0%	2.5V	3-Pin SOT-89
SPX385S-2.5	2.0%	2.5V	8-Pin NSOIC
SPX385S-2.5/TR	2.0%	2.5V	8-Pin NSOIC
SPX385N-2.5	2.0%	2.5V	3-Pin TO-92
SPX385N-2.5/TR	2.0%	2.5V	3-Pin TO-92

Available in lead free packaging. To order add "-L" suffix to part number.

Example: SPX385S-2.5/TR = standard; SPX385S-L-2.5/TR = lead free

/TR = Tape and Reel

Pack quantity is 2000 for TO-92 and 2500 for SOT-23, SOT-89 and NSOIC.



Exar Corporation

**Headquarters and
Sales Office:**
48720 Kato Road
Fremont, CA 94538
main: 510-668-7000
fax: 510-668-7030

Exar Corporation reserves the right to make changes to any products described herein. Exar does not assume any liability arising out of the application or use of any product or circuit described herein; neither does it convey any license under its patent rights nor the rights of others.