



Chipsmall Limited consists of a professional team with an average of over 10 year of expertise in the distribution of electronic components. Based in Hongkong, we have already established firm and mutual-benefit business relationships with customers from,Europe,America and south Asia,supplying obsolete and hard-to-find components to meet their specific needs.

With the principle of "Quality Parts,Customers Priority,Honest Operation,and Considerate Service",our business mainly focus on the distribution of electronic components. Line cards we deal with include Microchip,ALPS,ROHM,Xilinx,Pulse,ON,Everlight and Freescale. Main products comprise IC,Modules,Potentiometer,IC Socket,Relay,Connector.Our parts cover such applications as commercial,industrial, and automotives areas.

We are looking forward to setting up business relationship with you and hope to provide you with the best service and solution. Let us make a better world for our industry!



Contact us

Tel: +86-755-8981 8866 Fax: +86-755-8427 6832

Email & Skype: info@chipsmall.com Web: www.chipsmall.com

Address: A1208, Overseas Decoration Building, #122 Zhenhua RD., Futian, Shenzhen, China



SQFlash SD Card Datasheet

(SQF-ISDx1-xG-21x)

CONTENTS

1. Overview 4

2. Standard Features 5

3. Additional Features 6

4. Pin Assignment and Block Diagram 8

5. Power Consumption 9

6. DC Characters 9

7. AC Characters 12

8. Dimensions 18

Appendix: Part Number Table 19

Revision History

Rev.	Date	History
0.1	2014/7/1	1. 1 st draft
0.2	2015/7/1	1. Update to 15nm MLC
0.3	2016/3/10	1. Add ultra MLC and wear leveling information
0.4	2016/3/15	1. Add TBW information

Advantech reserves the right to make changes without further notice to any products or data herein to improve reliability, function, or design. Information furnished by Advantech is believed to be accurate and reliable. However, Advantech does not assure any liability arising out of the application or use of this information, nor the application or use of any product or circuit described herein, neither does it convey any license under its patent rights nor the rights of others.

Copyright © 1983-2010 Advantech Co., Ltd. All rights reserved.

1. Overview

The Industrial SD Card (ISD) of the SQFlash is fully compliant to the specification released by SD Card Association. The Command List supports [Part 1 Physical Layer Specification Ver3.1 Final] definitions. Card Capacity of Non-secure Area, Secure Area Supports [Part 3 Security Specification Ver3.0 Final] Specifications.

The SQF-ISD is based on 9-pin interface, designed to operate at a maximum operating frequency of 100MHz. It can alternate communication protocol between the SD mode and SPI mode. It performs data error detection and correction with very low power consumption. Current capacity would be offered from 4GB to 64GB; it's possible to reach 2TB in the future with ex-FAT, which is called SDXC (Extended Capacity SD Memory Card).

The SQF-ISD is specifically made for any rigorous environments where devices need to be operated at extended temperature, and strong data integrity and reliability are demanded. Such environments include both industrial and automotive applications. The SQF-ISD is the best choice for exceptional reliability, excellent performance and wide compatibility.

2. Standard Features

- Support SD system specification version 2.0 and 3.0. and compliant with UHS-I
- Card Capacity of Non-secure Area, Secure Area Supports [Part 3 Security Specification Ver3.0 Final] Specifications
- Support SD SPI mode
- Designed for read-only and read/write cards.
- The Command List supports [Part 1 Physical Layer Specification Ver3.01 Final] definitions
- Copyrights Protection Mechanism - Complies with highest security of SDMI standard
- CPRM (Content Protection for Recordable Media) of SD Card supported
- Support up to 72bits BCH ECC circuits to protect data communication.
- Global Wear Leveling support
 - SQFlash provides advanced Wear Leveling algorithm, which can efficiently spread out the flash usage through the whole flash media area. Moreover, by implementing both dynamic and static Wear Leveling algorithms, the life expectancy of the NAND Flash is greatly improved.
- Card removal during read operation will never harm the content
- Password Protection of cards (option)
- Write Protect feature using mechanical switch
- Built-in write protection features (permanent and temporary)
- High transmission speed
- +4KV/-4KV ESD protection in contact pads
- Dimensions: 32mm (L) x 24mm (W) x 2.1mm (H)
- Operating voltage range : 2.7-3.6V

3. Additional Features

■ Capacities

- SLC type : 128MB , 256MB , 512MB , 1GB , 2GB , 4GB , 8GB , 16GB , 32GB
- Ultra MLC type : 4GB , 8GB , 16GB , 32GB , 64GB
- MLC type : 8GB , 16GB , 32GB , 64GB , 128GB

■ Flash type

- SLC : 32nm for 1G / 2G, the rest are 24nm
- MLC : 15nm

■ Performance (MB per sec)

- Max. Read / Write: 90 / 45

■ Temperature Ranges

- Commercial Temperature
 - 0°C to 70°C
- Industrial Temperature
 - -40°C to 85°C

■ Mechanical Specification

- Shock : 1,500G, Peak / 0.5ms
- Vibration : 5G, Peak / 10~2000Hz
- Drop Test: 1.5m free fall
- Torque Test: 0.15N-m or +/-2.5deg
- Switch Cycles Test: Slide 0.4N to 5N

■ Humidity

- Operating Humidity : 5% ~ 93%
- Non-Operating Humidity : 5% ~ 93%

■ NAND flash Data Retention

- 10 years

■ **Endurance**

JEDEC defined an endurance rating TBW (TeraByte Written), following by the equation below, for indicating the number of terabytes a flash drive can be written which is a measurement of flash drive's expected lifespan, represents the amount of data written to the device.

$$TBW = [(NAND\ Endurance) \times (Flash\ Drive\ Capacity)] / WAF$$

- **NAND Endurance:** Program / Erase cycle of a NAND flash.
 - SLC: 60,000 cycles
 - Ultra MLC: 20,000 cycles
 - MLC: 3,000 cycles
- **Flash Drive Capacity:** Physical capacity in total of a Flash Drive.
- **WAF:** Write Amplification Factor (WAF), as the equation shown below, is a numerical value representing the ratio between the amount of data that a flash drive controller needs to write and the amount of data that the host's flash controller writes. A better WAF, which is near to 1, guarantees better endurance and lower frequency of data written to flash memory.

$$WAF = (Lifetime\ write\ to\ flash) / (Lifetime\ write\ to\ host)$$

The TBW rating for a flash drive shall be derived for and verified under the following workload conditions,

- Sequential Write (copy file into card)
- P/E cycles incurred: erase count after writing – erase count before writing

➤ **SQFlash SD Card TBW**

	WAF	TBW		
		SLC	Ultra MLC	MLC
1 GB	1.02441	57	--	--
2 GB	1.02564	114	--	--
4 GB	1.03013	227	75	--
8 GB	1.03226	454	151	22
16 GB	1.03226	908	302	45
32 GB	1.03060	1819	606	90
64 GB	TBD	--	TBD	TBD
128 GB	TBD	--	--	TBD

4. Pin Assignment and Block Diagram

SD memory Card Pad Assignment

pin	SD Mode			SPI Mode		
	Name	Type ⁽¹⁾	Description	Name	Type	Description
1	CD/DAT3 ⁽²⁾	I/O/PP ⁽³⁾	Card Detect/ Data Line[bit3]	CS	I ⁽³⁾	Chip Select (net true)
2	CMD	PP	Command/Response	DI	I	Data In
3	V _{SS1}	S	Supply voltage ground	VSS	S	Supply voltage ground
4	V _{DD}	S	Supply voltage	VDD	S	Supply voltage
5	CLK	I	Clock	SCLK	I	Clock
6	V _{SS2}	S	Supply voltage ground	VSS2	S	Supply voltage ground
7	DAT0	I/O/PP	Data Line[bit0]	DO	O/PP	Data Out
8	DAT1	I/O/PP	Data Line[bit1]	RSV		
9	DAT2	I/O/PP	Data Line[bit2]	RSV		

- (1) S: power supply, I:input; O:output using push-pull drivers; PP:I/O using push-pull drivers
- (2) The extended DAT lines (DAT1-DAT3) are input on power up. They start to operate as DAT lines after SET_BUS_WIDTH command. The Host shall keep its own DAT1-DAT3 lines in input mode, as well, while they are not used. It is defined so, in order to keep compatibility to MultiMedia Cards.
- (3) At power up this line has a 50KOhm pull up enabled in the card. This resistor serves two functions Card detection and Mode Selection. For Mode Selection, the host can drive the line high or let it be pulled high to select SD mode. If the host wants to select SPI mode it should drive the line low. For Card detection, the host detects that the line is pulled high. This pull-up should be disconnected by the user, during regular data transfer, with SET_CLR_CARD_DETECT (ACMD42) command.

Name	Width	Description
CID	128bit	Card identification number; card individual number for identification. Mandatory
RCA	16bit	Relative card address; local system address of a card, dynamically suggested by the card and approved by the host during initialization. Mandatory
DSR	16bit	Driver Stage Register; to configure the card's output drivers. Optional
CSD	128bit	Card Specific Data; information about the card operation conditions. Mandatory
SCR	64bit	SD Configuration Register; information about the SD Memory Card's Special Features capabilities. Mandatory
OCR	32bit	Operation condition registers. Mandatory
SSR	512bit	SD Status; information about the card proprietary features. Mandatory
OCR	32bit	Card Status; information about the card status. Mandatory

5. Power Consumption

Table list as below is the power consumption of ISD card with different type of flash memory.

Capacity	Flash Structure	Read (mA)	Write (mA)	Idle (uA)
64GB	32GB x 2, COB (Wide Temp.) 8GB x 8, SIP (Std. Temp.)	200	200	250

(1) Data transfer mode is single channel.

(2) Power Consumption may differ according to flash configuration, SDR configuration, or platform.

6. DC Characters

6.1 BUS Operating Conditions for 3.3V Signaling

- Threshold level for High Voltage Range

Parameter	Symbol	Min	Max	Unit	Remarks
Supply voltage	V _{DD}	2.7	3.6	V	
Output High Voltage	VOH	0.75*VDD		V	IOH=-100uA V _{DD} Min.
Output Low Voltage	VOL		0.125*VDD	V	IOL = 100uA V _{DD} min
Input High Voltage	VIH	0.625*VDD	VDD+0.3	V	
Input Low Voltage	VIL	VSS-0.3	0.25 *VDD	V	
Power up time			250	ms	From 0v to V _{DD} min.

- Peak Voltage and Leakage Current

Parameter	Symbol	Min	Max	Unit	Remarks
Peak voltage on all lines		-0.3	V _{DD} +0.3	V	
All Inputs					
Input Leakage Current		-10	10	uA	
All Outputs					
Output Leakage Current		-10	10	uA	

- Threshold Level for 1.8V Signaling

Parameter	Symbol	Min	Max	Unit	Condition
Supply Voltage	V _{DD}	2.7	3.6	V	
Regulator Voltage	V _{DDIO}	1.7	1.95	V	Generated by V _{DD}
Output High Voltage	VOH	1.4	-	V	IOH = -2mA
Output Low Voltage	VOL		0.45	V	IOL = 2mA
Input High Voltage	VIH	1.27	2.00	V	
Input Low Voltage	VIL	V _{ss} - 0.3	0.58	V	

- Input Leakage Current for 1.8V Signaling

Parameter	Symbol	Min	Max	Unit	Remarks
Input Leakage Current		-2	2	uA	DAT3 pull-up is disconnected.

6.2 BUS Operating Conditions for 3.3V Signaling

- BUS Circuitry Diagram:

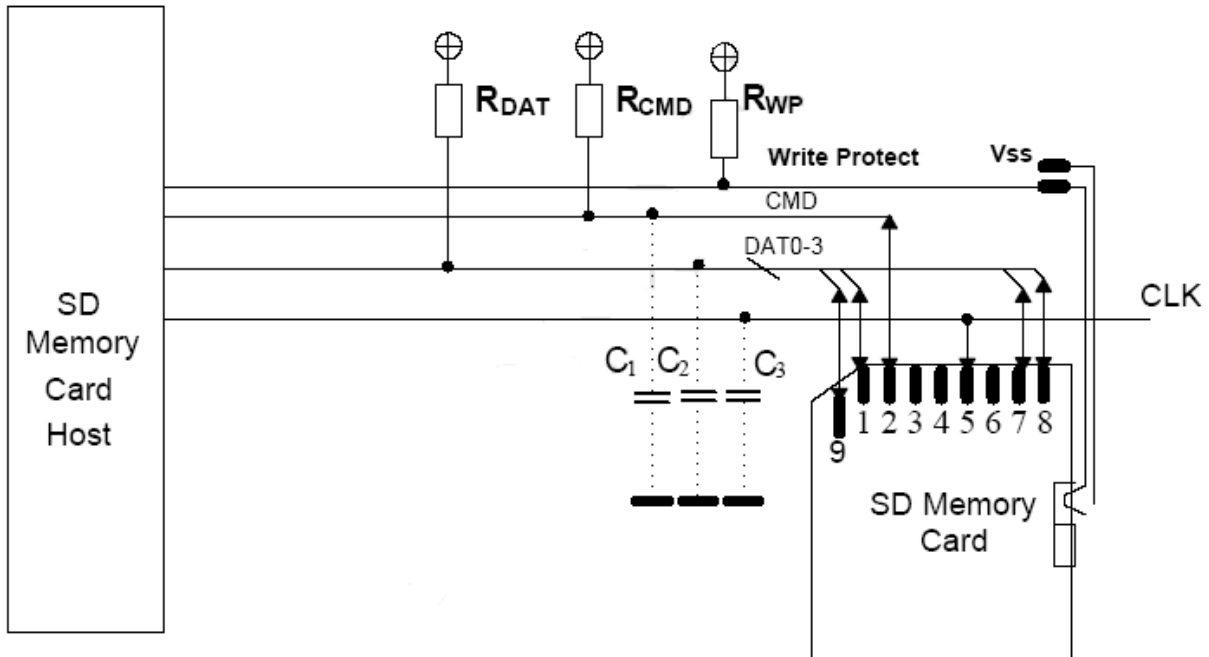

- BUS Operating Conditions – Signal Line’s Load
Total bus capacitance = $C_{HOST} + C_{BUS} + N \cdot C_{CARD}$

Parameter	Symbol	Min	Max	Unit	Remark
Pull-up resistance	R_{CMD} R_{DAT}	10	100	kΩ	to prevent bus floating
Total bus capacitance for each signal line	C_L		40	pF	1 card $C_{HOST}+C_{BUS}$ shall not exceed 30 pF
Capacitance of the card for each signal pin	C_{CARD}		10	pF	
Maximum signal line inductance			16	nH	
Pull-up resistance inside card (pin1)	R_{DAT3}	10	90	kΩ	May be used for card detection
Capacitance Connected to Power Line	C_C		5	uF	To prevent inrush current

6.3 Power Up Time

- Host needs to keep power line level less than 0.5V and more than 1ms before power ramp up.

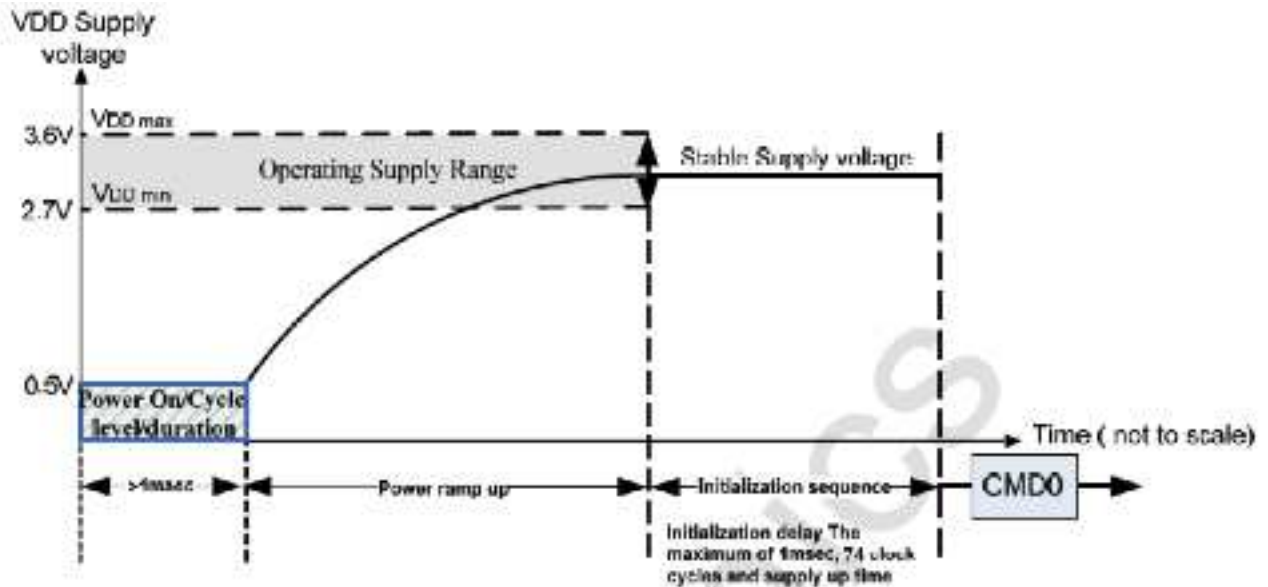

Power On or Power Cycle

Followings are requirements for Power on and Power cycle to assure a reliable SD Card hard reset.

- (1) Voltage level shall be below 0.5V
- (2) Duration shall be at least 1ms.

Power Supply Ramp Up

The power ramp up time is defined from 0.5V threshold level up to the operating supply voltage which is stable between VDD(min.) and VDD(max.) and host can supply SDCLK. Followings are recommendation of Power ramp up:

- (1) Voltage of power ramp up should be monotonic as much as possible.
- (2) The minimum ramp up time should be 0.1ms.
- (3) The maximum ramp up time should be 35ms for 2.7-3.6V power supply.

Power Down and Power Cycle

- When the host shuts down the power, the card VDD shall be lowered to less than 0.5Volt for a minimum period of 1ms. During power down, DAT, CMD, and CLK should be disconnected or driven to logical 0 by the host to avoid a situation that the operating current is drawn through the signal lines.
- If the host needs to change the operating voltage, a power cycle is required. Power cycle means the power is turned off and supplied again. Power cycle is also needed for accessing cards that are already in Inactive State. To create a power cycle the host shall follow the power down description before power up the card (i.e. the card VDD shall be once lowered to less than 0.5Volt for a minimum period of 1ms).

7. AC Characters

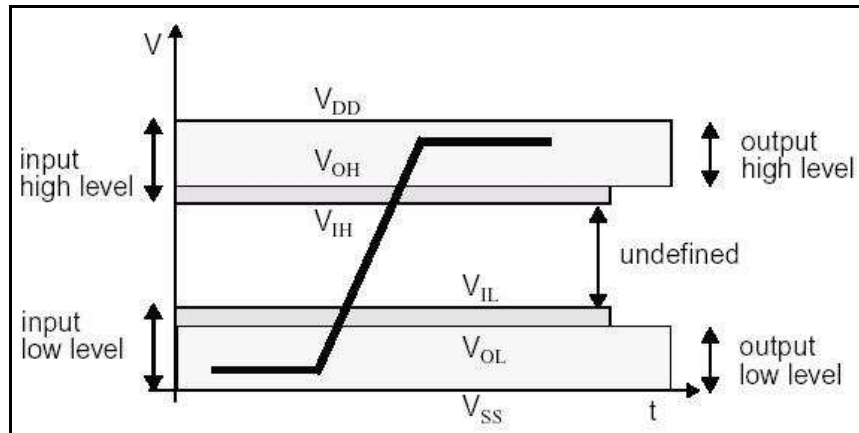

7.1 SD Interface Timing (Default)

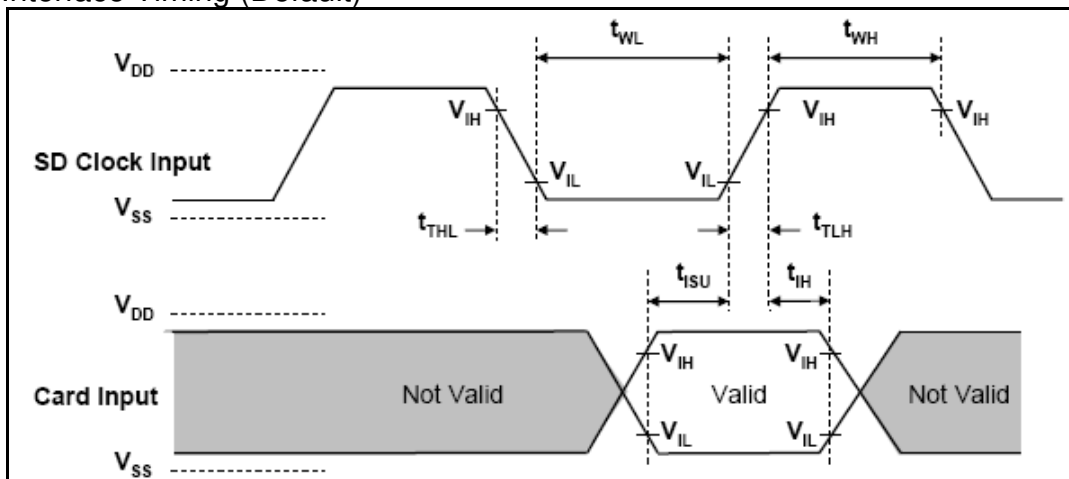

Card Input Timing (Default Speed Card)

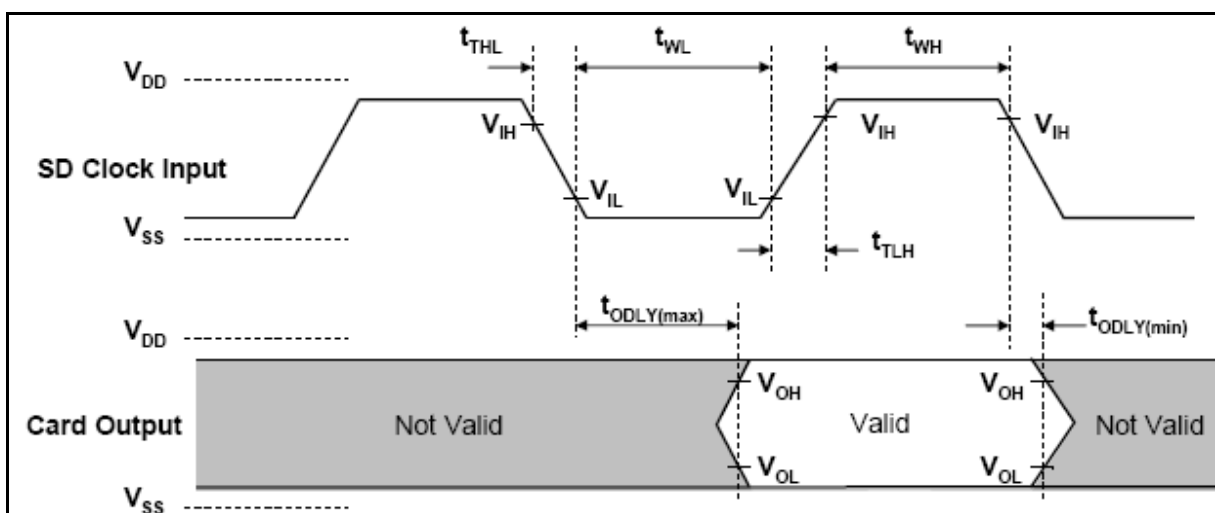

Card Output Timing (Default Speed Mode)

Parameter	Symbol	Min	Max	Unit	Remark
Clock CLK (All values are referred to min(V_{IH}) and max(V_{IL}))					
Clock frequency Data Transfer Mode	f _{PP}	0	25	MHz	C _{card} ≤ 10 pF (1 card)
Clock frequency Identification Mode	f _{OD}	0 ₍₁₎ /100	400	kHz	C _{card} ≤ 10 pF (1 card)
Clock low time	t _{WL}	10		ns	C _{card} ≤ 10 pF (1 card)
Clock high time	t _{WH}	10		ns	C _{card} ≤ 10 pF (1 card)
Clock rise time	t _{TLH}		10	ns	C _{card} ≤ 10 pF (1 card)
Clock fall time	t _{THL}		10	ns	C _{card} ≤ 10 pF (1 card)
Inputs CMD, DAT (referenced to CLK)					
Input set-up time	t _{ISU}	5		ns	C _{card} ≤ 10 pF (1 card)
Input hold time	t _{IH}	5		ns	C _{card} ≤ 10 pF (1 card)
Outputs CMD, DAT (referenced to CLK)					
Output Delay time during Data Transfer Mode	t _{ODLY}	0	14	ns	C _L ≤ 40 pF (1 card)
Output Delay time during Identification Mode	t _{ODLY}	0	50	ns	C _L ≤ 40 pF (1 card)

(1) 0Hz means to stop the clock. The given minimum frequency range is for cases where continuous clock is required.

7.2 SD Interface Timing (High-speed Mode)

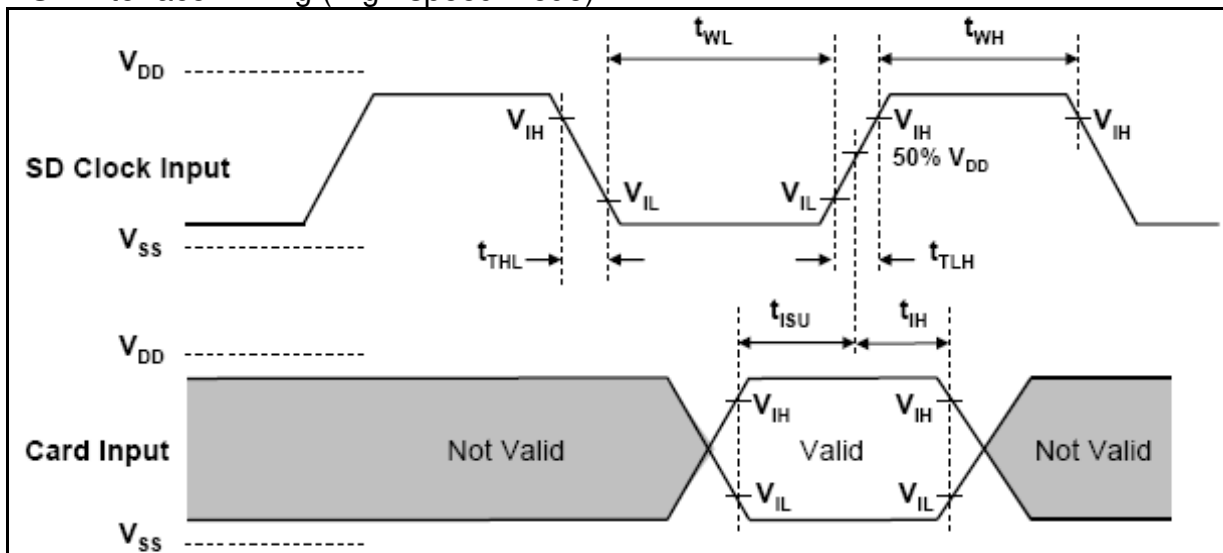

Card Input Timing (High Speed Card)

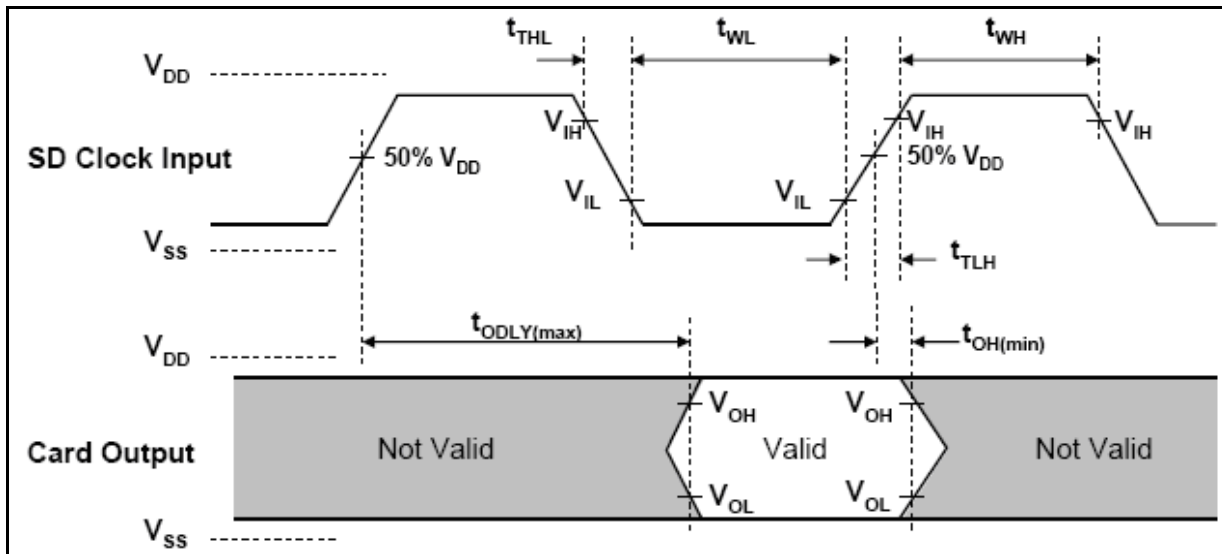

Card Output Timing (Default Speed Mode)

Parameter	Symbol	Min	Max	Unit	Remark
Clock CLK (All values are referred to min(V_{IH}) and max(V_{IL}))					
Clock frequency Data Transfer Mode	f _{PP}	0	50	MHz	C _{card} ≤ 10 pF (1 card)
Clock low time	t _{WL}	7		ns	C _{card} ≤ 10 pF (1 card)
Clock high time	t _{WH}	7		ns	C _{card} ≤ 10 pF (1 card)
Clock rise time	t _{TLH}		3	ns	C _{card} ≤ 10 pF (1 card)
Clock fall time	t _{THL}		3	ns	C _{card} ≤ 10 pF (1 card)
Inputs CMD, DAT (referenced to CLK)					
Input set-up time	t _{ISU}	6		ns	C _{card} ≤ 10 pF (1 card)
Input hold time	t _{IH}	2		ns	C _{card} ≤ 10 pF (1 card)
Outputs CMD, DAT (referenced to CLK)					
Output Delay time during Data Transfer Mode	t _{ODLY}		14	ns	C _L ≤ 40 pF (1 card)
Output Hold time	T _{OH}	2.5	50	ns	C _L ≤ 15 pF (1 card)
Total System capacitance of each line ¹	C _L		40	pF	C _L ≤ 15 pF (1 card)

(1) In order to satisfy severe timing, host shall drive only one card.

7.3 SD Interface timing (SDR12, SDR25 and SDR50 Modes)

- Input:

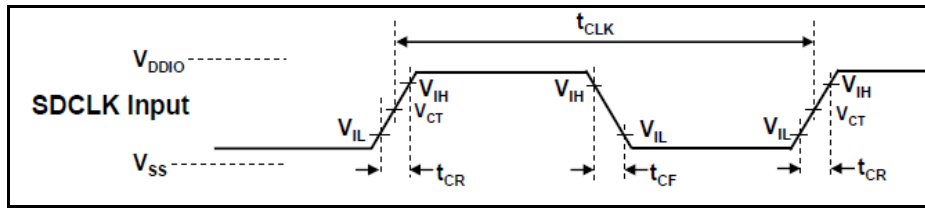

Symbol	Min	Max	Unit	Remark
tCLK	4.80	0	ns	208MHz (Max.), Between rising edge, VCT= 0.975V
tCR, tCF	-	0.2 * tCLK	ns	tCR, tCF < 2.00ns (max.) at 100MHz, CCARD=10pF
Clock Duty	30	70	%	

Clock Signal Timing

- SDR50 Input Timing:

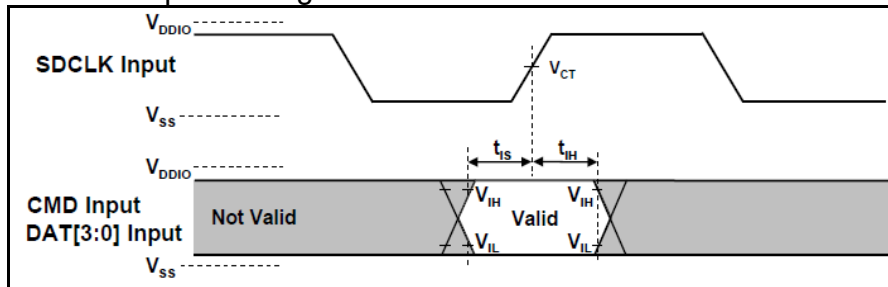

Symbol	Min	Max	Unit	Remark
tIS	3.00	-	ns	CCARD =10pF, VCT= 0.975V
tIH	0.80	-	ns	CCARD =5pF, VCT= 0.975V

Card Input Timing

- Output:

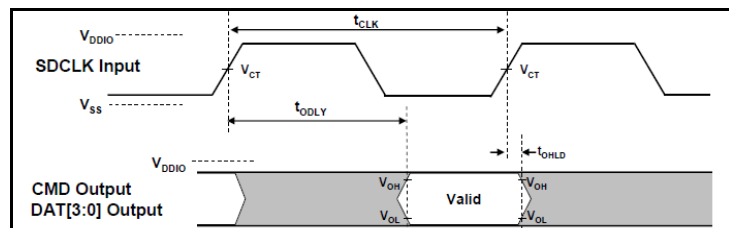

Symbol	Min	Max	Unit	Remark
tODLY	-	7.5	ns	tCLK>=10.0ns, CL=30pF, using driver Type B, for SDR50
tODLY	-	14	ns	tCLK>=20.0ns, CL=40pF, using driver Type B, for SDR25 and SDR12,
TOH	1.5	-	ns	Hold time at the tODLY (min.), CL=15pF

Output Timing of Fixed Data Window

7.4 SD Interface timing (DDR50 Modes)

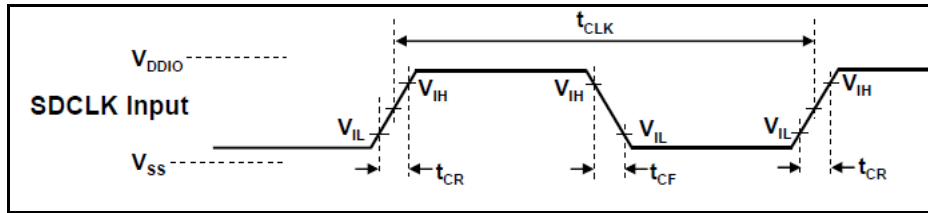

Symbol	Min	Max	Unit	Remark
t_{CLK}	20	-	ns	50MHz (Max.), Between rising edge
t_{CR}, t_{CF}	-	$0.2 * t_{CLK}$	ns	$t_{CR}, t_{CF} < 4.00ns$ (max.) at 50MHz, $CCARD=10pF$
Clock Duty	45	55	%	

Clock Signal Timing

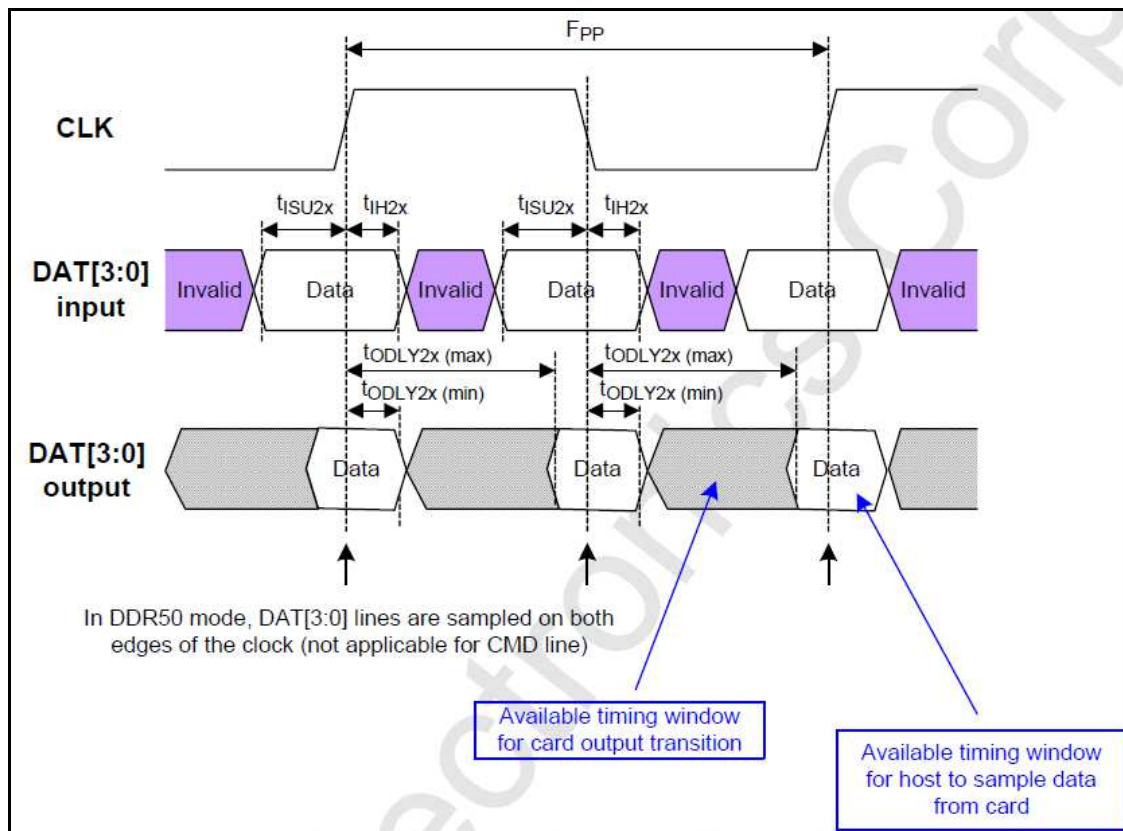

Timing Diagram DAT Inputs / Outputs Referenced to CLK in DDR50 Mode

Parameter	Symbol	Min	Max	Unit	Remark
Input CMD (referenced to CLK rising edge)					
Input set-up time	t_{ISU}	6	-	ns	$C_{card} \leq 10$ pF (1 card)
Input hold time	t_{IH}	0.8	-	ns	$C_{card} \leq 10$ pF (1 card)
Output CMD (referenced to CLK rising edge)					
Output Delay time during Data Transfer Mode	t_{ODLY}		13.7	ns	$C_{card} \leq 30$ pF (1 card)
Output Hold time	t_{OH}	1.5	-	ns	$C_{card} \leq 10$ pF (1 card)
Inputs DAT (referenced to CLK rising and falling edges)					
Input set-up time	t_{ISU2X}	3	-	ns	$C_{card} \leq 10$ pF (1 card)
Input hold time	t_{IH2X}	0.8	-	ns	$C_{card} \leq 10$ pF (1 card)
Outputs CMD, DAT (referenced to CLK)					
Output Delay time during Data Transfer Mode	t_{ODLY2X}	-	7.0	ns	$C_L \leq 25$ pF (1 card)
Output Hold time	t_{OH2X}	1.5	-	ns	$C_L \geq 15$ pF (1 card)

8. Dimensions

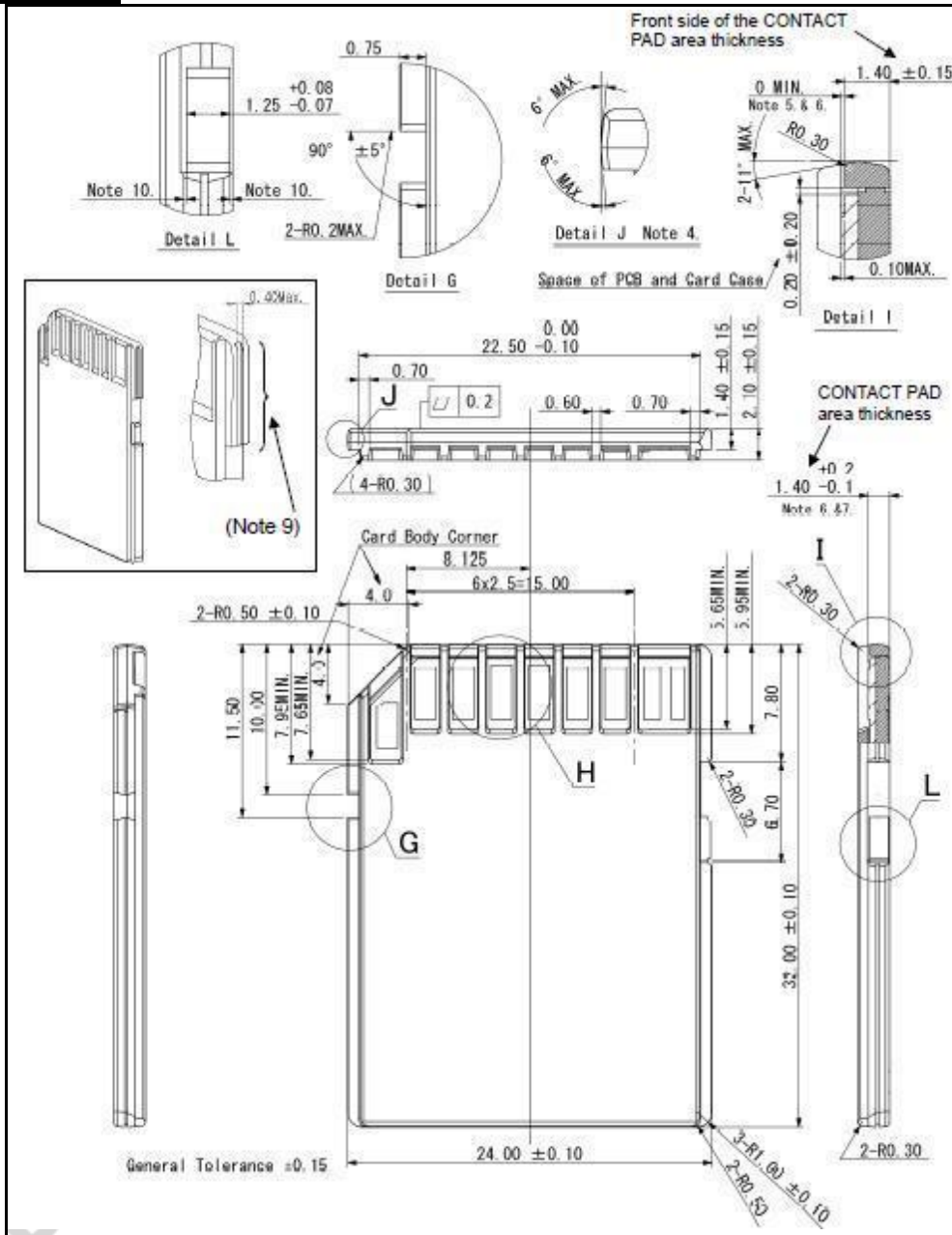

Dimensions of A SD Card (Bottom View, DIN)

Appendix: Part Number Table
SLC

Product	Advantech PN
SQF I-SD C6 SLC 128M (0~70°C)	SQF-ISDS1-128M-21C
SQF I-SD C6 SLC 256M (0~70°C)	SQF-ISDS1-256M-21C
SQF I-SD C6 SLC 512M (0~70°C)	SQF-ISDS1-512M-21C
SQF I-SD C6 SLC 1G (0~70°C)	SQF-ISDS1-1G-21C
SQF I-SD C6 SLC 2G (0~70°C)	SQF-ISDS1-2G-21C
SQF I-SD C6 SLC 4G (0~70°C)	SQF-ISDS1-4G-21C
SQF I-SD C10 SLC 8G (0~70°C)	SQF-ISDS1-8G-21C
SQF I-SD C10 SLC 16G (0~70°C)	SQF-ISDS1-16G-21C
SQF I-SD C10 SLC 32G (0~70°C)	SQF-ISDS1-32G-21C
SQF I-SD C6 SLC 128M (-40~85°C)	SQF-ISDS1-128M-21E
SQF I-SD C6 SLC 256M (-40~85°C)	SQF-ISDS1-256M-21E
SQF I-SD C6 SLC 512M (-40~85°C)	SQF-ISDS1-512M-21E
SQF I-SD C6 SLC 1G (-40~85°C)	SQF-ISDS1-1G-21E
SQF I-SD C6 SLC 2G (-40~85°C)	SQF-ISDS1-2G-21E
SQF I-SD C6 SLC 4G (-40~85°C)	SQF-ISDS1-4G-21E
SQF I-SD C10 SLC 8G (-40~85°C)	SQF-ISDS1-8G-21E
SQF I-SD C10 SLC 16G (-40~85°C)	SQF-ISDS1-16G-21E
SQF I-SD C10 SLC 32G (-40~85°C)	SQF-ISDS1-32G-21E

Ultra MLC

Product	Advantech PN
SQF I-SD UHS-I UMLC 4G (0~70°C)	SQF-ISDU1-4G-21C
SQF I-SD UHS-I UMLC 8G (0~70°C)	SQF-ISDU1-8G-21C
SQF I-SD UHS-I UMLC 16G (0~70°C)	SQF-ISDU1-16G-21C
SQF I-SD UHS-I UMLC 32G (0~70°C)	SQF-ISDU1-32G-21C
SQF I-SD UHS-I UMLC 64G (0~70°C)	SQF-ISDU1-64G-21C
SQF I-SD UHS-I UMLC 4G (-40~85°C)	SQF-ISDU1-4G-21E
SQF I-SD UHS-I UMLC 8G (-40~85°C)	SQF-ISDU1-8G-21E
SQF I-SD UHS-I UMLC 16G (-40~85°C)	SQF-ISDU1-16G-21E
SQF I-SD UHS-I UMLC 32G (-40~85°C)	SQF-ISDU1-32G-21E
SQF I-SD UHS-I UMLC 64G (-40~85°C)	SQF-ISDU1-64G-21E

MLC

Product	Advantech PN
SQF I-SD UHS-I MLC 8G (0~70°C)	SQF-ISDM1-8G-21C
SQF I-SD UHS-I MLC 16G (0~70°C)	SQF-ISDM1-16G-21C
SQF I-SD UHS-I MLC 32G (0~70°C)	SQF-ISDM1-32G-21C
SQF I-SD UHS-I MLC 64G (0~70°C)	SQF-ISDM1-64G-21C
SQF I-SD UHS-I MLC 128G (0~70°C)	SQF-ISDM1-128G-21C
SQF I-SD UHS-I MLC 8G (-40~85°C)	SQF-ISDM1-8G-21E
SQF I-SD UHS-I MLC 16G (-40~85°C)	SQF-ISDM1-16G-21E
SQF I-SD UHS-I MLC 32G (-40~85°C)	SQF-ISDM1-32G-21E
SQF I-SD UHS-I MLC 64G (-40~85°C)	SQF-ISDM1-64G-21E
SQF I-SD UHS-I MLC 128G (-40~85°C)	SQF-ISDM1-128G-21E