



Chipsmall Limited consists of a professional team with an average of over 10 year of expertise in the distribution of electronic components. Based in Hongkong, we have already established firm and mutual-benefit business relationships with customers from,Europe,America and south Asia,supplying obsolete and hard-to-find components to meet their specific needs.

With the principle of “Quality Parts,Customers Priority,Honest Operation,and Considerate Service”,our business mainly focus on the distribution of electronic components. Line cards we deal with include Microchip,ALPS,ROHM,Xilinx,Pulse,ON,Everlight and Freescale. Main products comprise IC,Modules,Potentiometer,IC Socket,Relay,Connector.Our parts cover such applications as commercial,industrial, and automotives areas.

We are looking forward to setting up business relationship with you and hope to provide you with the best service and solution. Let us make a better world for our industry!



Contact us

Tel: +86-755-8981 8866 Fax: +86-755-8427 6832

Email & Skype: info@chipsmall.com Web: www.chipsmall.com

Address: A1208, Overseas Decoration Building, #122 Zhenhua RD., Futian, Shenzhen, China



MODELS:

SR25UB / SR25UBEXP

SmartRack® 25U Standard-Depth Server Rack Enclosure Cabinet
(with or without side panels)



25 Rack Units



3000 lb.
Stationary
Load Capacity



2250 lb.
Rolling
Load Capacity



Heavy-Duty
Casters



Locking Doors &
Side Panels



Standard
19 in.
Rack Width



Toolless
Mounting Slots



Adjustable
Rails with
Easy-View
Depth Index

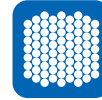

Airflow
Exceeds
Server OEM
Requirements



Integrated
Baying Tabs



Square Hole
Mounting

- A** Adjustable Mounting Rails
- B** Adjustable PDU Mounting Rails with Toolless Mounting Slots
- C** Roof Panel (Removable)
- D** Front Door (Lockable/Removable/Reversible)
- E** Split Rear Doors (Lockable/Removable)
- F** Side Panels (not included with SR25UBEXP) (Lockable/Removable)
- G** Heavy-Duty Casters
- H** Heavy-Duty Levelers
- I** Keys (For doors and side panels)

Also Includes: Owner's manual, 2 shipping/stabilizing brackets and equipment-mounting hardware (50 M6 cage nuts, 50 M6 washers, 50 M6 screws)

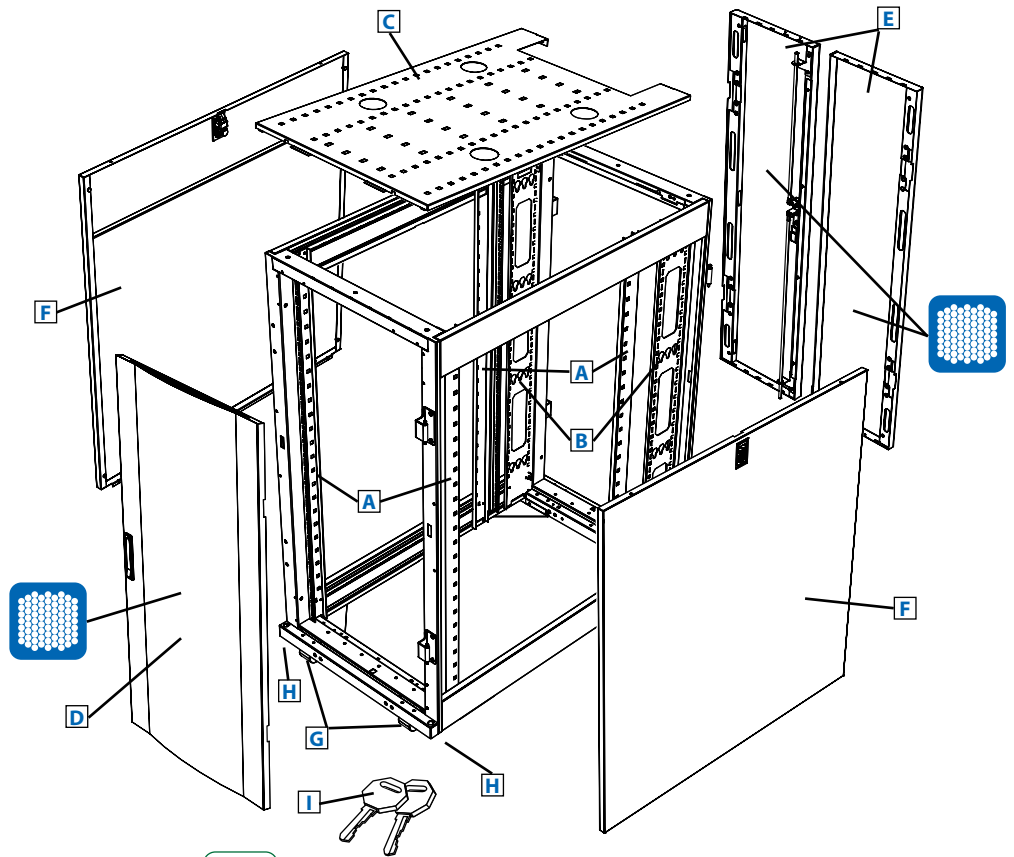

Specifications

Model	SR25UB
Rack Spaces	25U
Stationary Load Capacity	3000 lb. (1363 kg)
Rolling Load Capacity	2250 lb. (1022 kg)
Unit Dimensions (H x W x D)	48.7 x 23.6 x 41.3 in. (1237 x 599 x 1049 mm)
Shipping Dimensions (H x W x D)	55 x 27.75 x 47 in. (1397 x 705 x 1194 mm)
Unit Weight	195 lb. (88.6 kg)
Shipping Weight	237 lb. (107.5 kg)
Standards	Meets EIA/ECA-310-E, RoHS, CE and UL 60950 (accommodates all standard 19 in. rack-mount equipment regardless of vendor)
Model	SR25UBEXP (Identical to SR25UB without side panels.)
Unit Weight	163 lb. (73.9 kg)
Shipping Weight	200 lb. (90.7 kg)



- Ships fully assembled for rapid deployment, but can be knocked down for easy reassembly in confined spaces
- Rolls into place on heavy-duty pre-installed removable casters
- Ideal for rack-mount server, network and telecom applications

SEE NEXT PAGE FOR DETAILED UNIT MEASUREMENTS



1111 W. 35th Street
Chicago, IL 60609 USA
773.869.1234
www.tripplite.com

Also Available: Shock pallet models with special packaging to facilitate equipment pre-installation and reshipment to final site. Heavy-duty shock pallet holds up to 1250 lb. (568 kg), including the weight of the enclosure and pre-installed equipment. Add "SP1" to model numbers above to order shock pallet models.

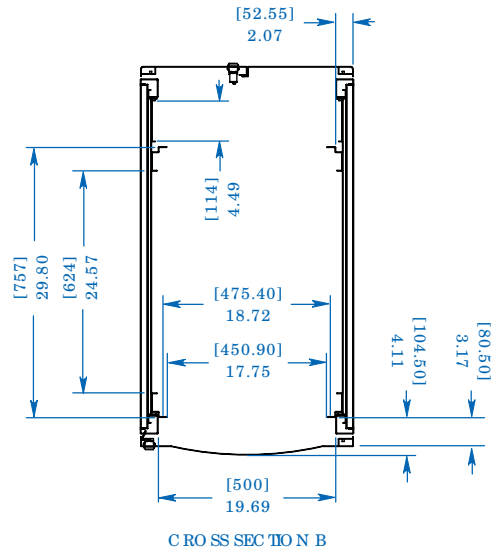
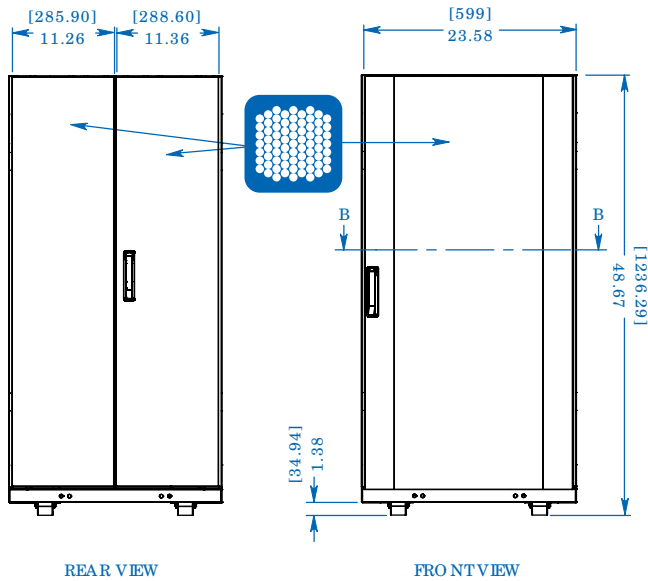
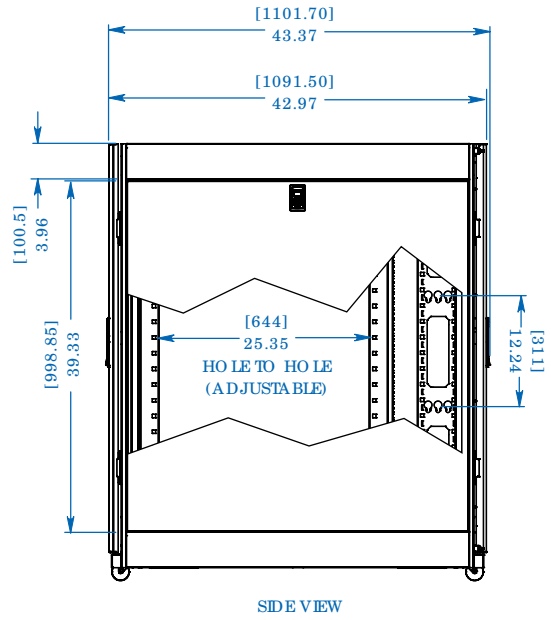
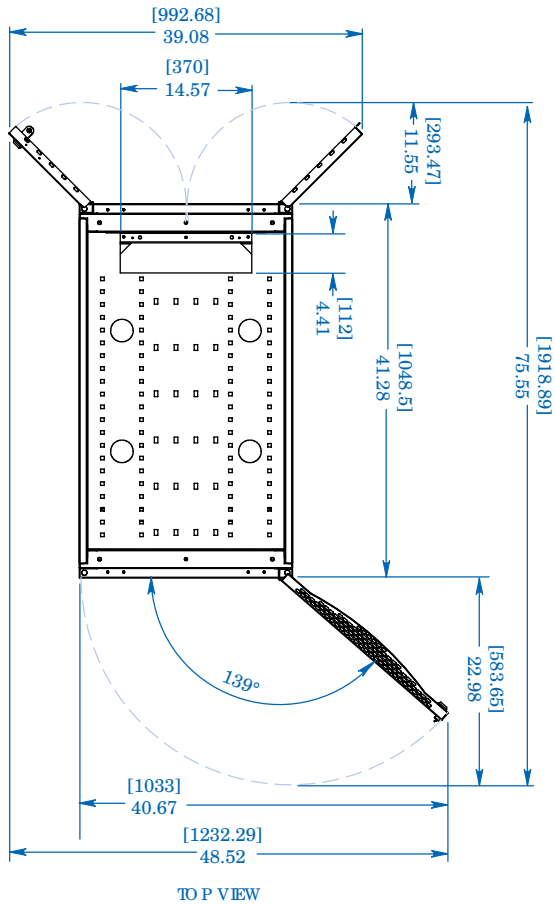

MODELS:
SR25UB
SR25UBEXP



Dimensions: [mm] INCHES

Tripp Lite has a policy of continuous improvement. Specifications are subject to change without notice.

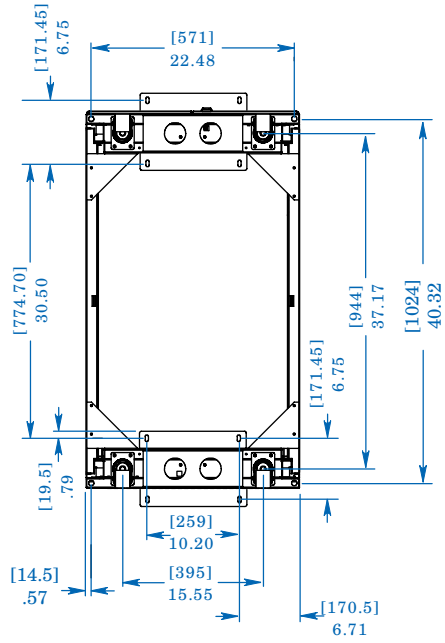

BO TTOM VIEW

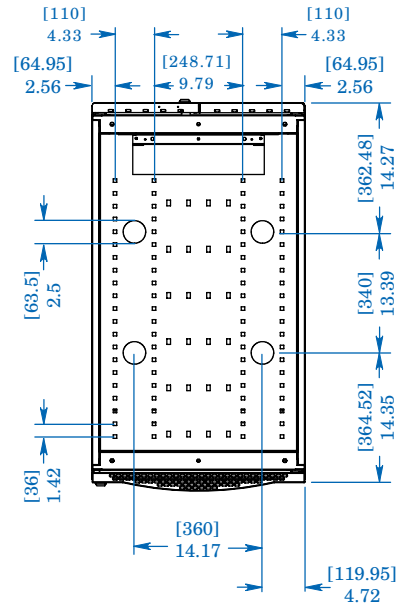

TO P VIEW

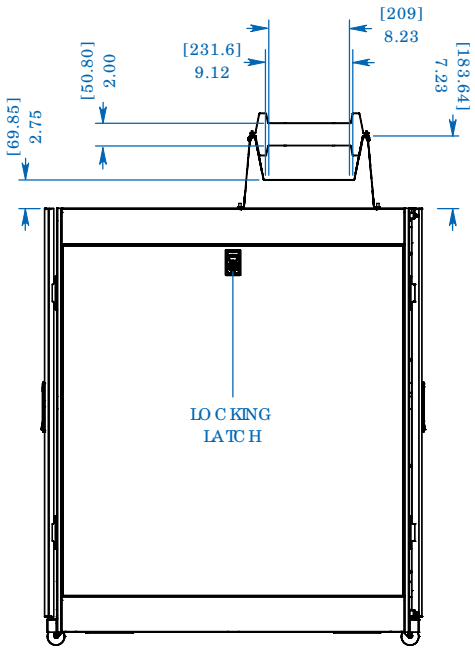

SIDE VIEW

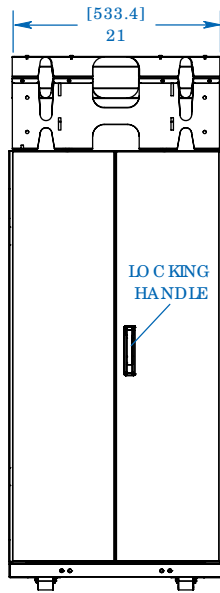

REAR VIEW

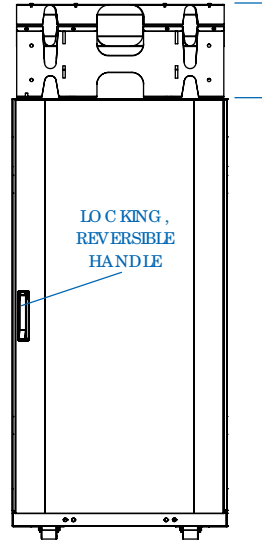

FRO NT VIEW

OPTIO NAL SRC A BLEIRA Y AND SRC A BLEIRA YEXP C A BLE MANA GEMENT ACC ESSO RIES SHOWN (MO UNTING POSITIO N ADJUSTS TO ACC OMMO DATE A WIDE RANG E OF APPLICATIO NS)

MODELS:
SR25UB
SR25UBEXP



1111 W. 35th Street
Chicago, IL 60609 USA
773.869.1234
www.tripplite.com

Dimensions: [mm] INCHES

Tripp Lite has a policy of continuous improvement. Specifications are subject to change without notice.