



Chipsmall Limited consists of a professional team with an average of over 10 year of expertise in the distribution of electronic components. Based in Hongkong, we have already established firm and mutual-benefit business relationships with customers from,Europe,America and south Asia,supplying obsolete and hard-to-find components to meet their specific needs.

With the principle of “Quality Parts,Customers Priority,Honest Operation,and Considerate Service”,our business mainly focus on the distribution of electronic components. Line cards we deal with include Microchip,ALPS,ROHM,Xilinx,Pulse,ON,Everlight and Freescale. Main products comprise IC,Modules,Potentiometer,IC Socket,Relay,Connector.Our parts cover such applications as commercial,industrial, and automotives areas.

We are looking forward to setting up business relationship with you and hope to provide you with the best service and solution. Let us make a better world for our industry!



Contact us

Tel: +86-755-8981 8866 Fax: +86-755-8427 6832

Email & Skype: info@chipsmall.com Web: www.chipsmall.com

Address: A1208, Overseas Decoration Building, #122 Zhenhua RD., Futian, Shenzhen, China



MODEL:

SR48UBWD

SmartRack™ Wide Rack Enclosure



48 Rack Units



3000 lb
Stationary
Load Rating



2250 lb
Rolling
Load Rating



Heavy-Duty
Casters



Locking Doors
& Side Panels



Accommodates
Standard
19-inch
Equipment



Toolless
Mounting Slots



Adjustable
Rails with
Easy-View
Depth Index



Airflow
Exceeds
Server OEM
Requirements



Integrated
Baying Tabs

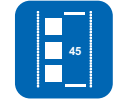

Square Hole
Mounting

- A** Adjustable Mounting Rails
- B** Adjustable PDU Mounting Rails with Toolless Mounting Slots
- C** Roof Panel (Removable)
- D** Front Door (Lockable/Removable/Reversible)
- E** Split Rear Doors (Lockable/Removable)
- F** Side Panels (Lockable/Removable)
- G** Heavy-Duty Casters
- H** Heavy-Duty Levelers
- I** Keys (For doors and side panels.)

Also Includes: Owner's manual, 2 stabilizing brackets and rackmount equipment mounting hardware (50 cage nuts, 50 mounting screws, 50 nylon cup washers).

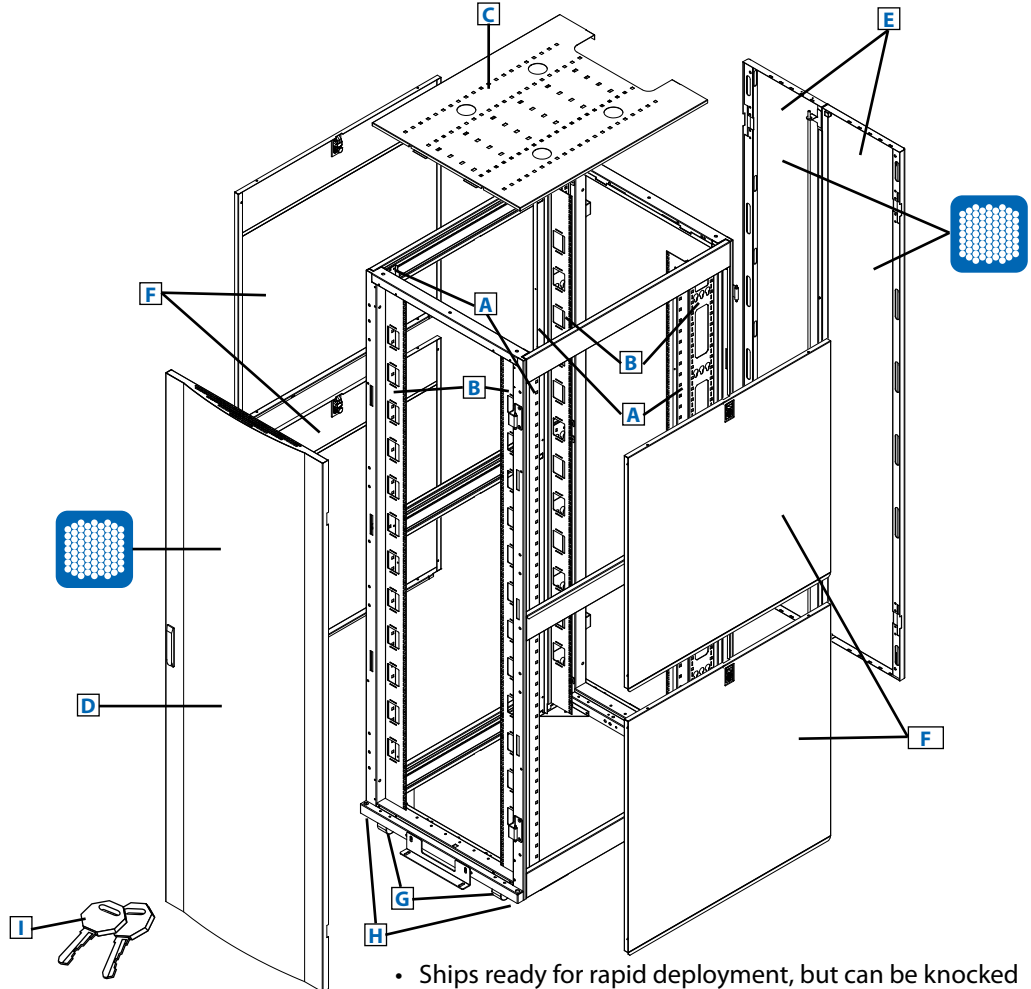

- Ships ready for rapid deployment, but can be knocked down for easy reassembly in confined spaces
- Modular design optimized for quick configuration and reconfiguration
- Ideal for rackmount server, network and telecom applications



Specifications

Model	SR48UBWD
Rack Spaces	48U
Stationary Load Rating	3000 lb (1363 kg)
Rolling Load Rating	2250 lb (1022 kg)
Unit Dimensions (H x W x D)	89 x 29.53 x 43 in. (2261 x 750 x 1092 mm)
Shipping Dimensions (H x W x D)	95 x 32 x 45 in. (2413 x 813 x 1143 mm)
Unit Weight	343 lb (156 kg)
Shipping Weight	395 lb (179 kg)
Certifications	Tested to UL 60950, TIA/EIA-310-E, NOM, ROHS, CE (Accommodates all standard 19-inch rackmount equipment regardless of vendor.)

Tripp Lite has a policy of continuous improvement. Specifications are subject to change without notice.

SEE NEXT PAGE FOR DETAILED UNIT MEASUREMENTS



1111 W. 35th Street
Chicago, IL 60609 USA
773.869.1234
www.tripplite.com

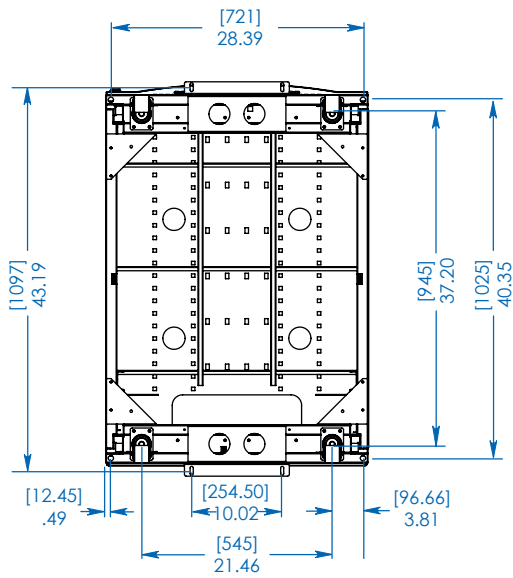

BOTTOM VIEW

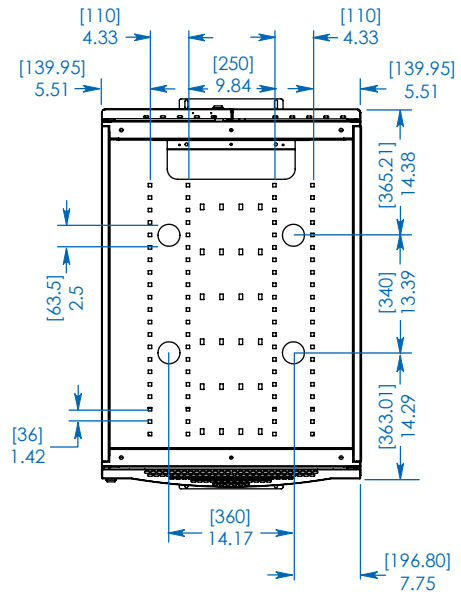

TOP VIEW

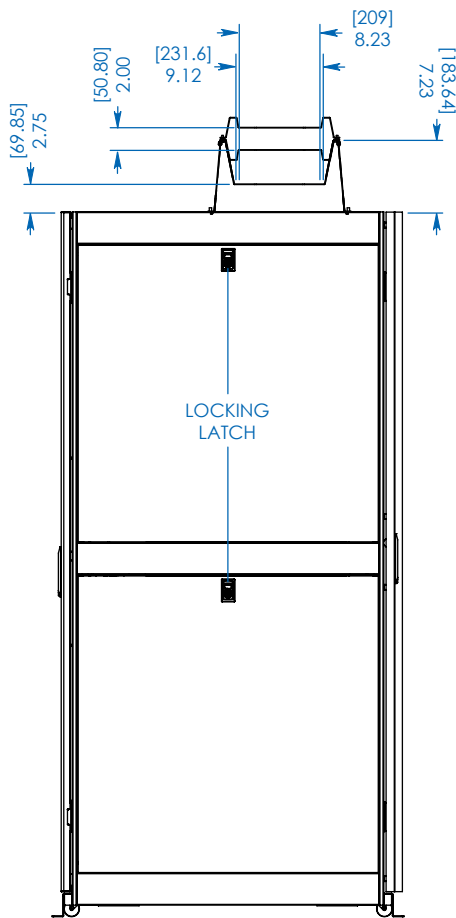

SIDE VIEW

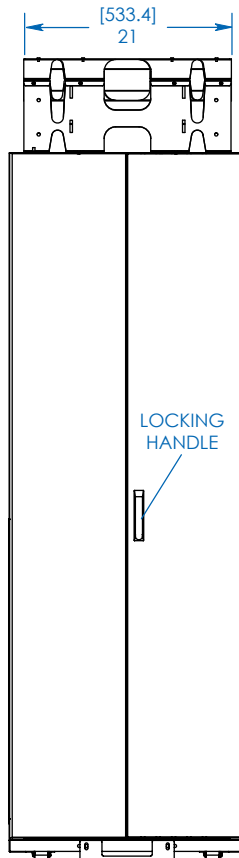

REAR VIEW

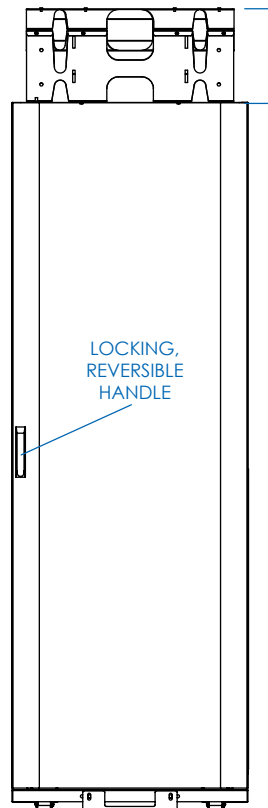

FRONT VIEW

OPTIONAL SRCABLETRAY AND SRCABLETRAYEXP CABLE MANAGEMENT ACCESSORIES SHOWN (MOUNTING POSITION ADJUSTS TO ACCOMMODATE A WIDE RANGE OF APPLICATIONS)

MODEL:
SR48UBWD



1111 W. 35th Street
Chicago, IL 60609 USA
773.869.1234
www.tripplite.com

Dimensions: [mm] INCHES

Tripp Lite has a policy of continuous improvement. Specifications are subject to change without notice.