



Chipsmall Limited consists of a professional team with an average of over 10 year of expertise in the distribution of electronic components. Based in Hongkong, we have already established firm and mutual-benefit business relationships with customers from,Europe,America and south Asia,supplying obsolete and hard-to-find components to meet their specific needs.

With the principle of “Quality Parts,Customers Priority,Honest Operation,and Considerate Service”,our business mainly focus on the distribution of electronic components. Line cards we deal with include Microchip,ALPS,ROHM,Xilinx,Pulse,ON,Everlight and Freescale. Main products comprise IC,Modules,Potentiometer,IC Socket,Relay,Connector.Our parts cover such applications as commercial,industrial, and automotives areas.

We are looking forward to setting up business relationship with you and hope to provide you with the best service and solution. Let us make a better world for our industry!



Contact us

Tel: +86-755-8981 8866 Fax: +86-755-8427 6832

Email & Skype: info@chipsmall.com Web: www.chipsmall.com

Address: A1208, Overseas Decoration Building, #122 Zhenhua RD., Futian, Shenzhen, China



THIS COPY IS PROVIDED ON A RESTRICTED BASIS AND IS NOT TO BE USED IN ANY WAY DETRIMENTAL TO THE INTERESTS OF PANDUIT CORP.

PANDUIT P/N	WEIGHT
SRBPPQBRKT	2.00 LB (0.907 kg)

NOTES:

1. SEE CURRENT CATALOG FOR ADDITIONAL PART NUMBER SUFFIXES TO INDICATE COLOR AND / OR PACKAGE QUANTITY.
2. SEE CATALOG FOR COMPLETE LIST OF PARTS APPLICABLE FOR USE WITH THIS PART.
3. DIMENSIONS IN PARENTHESES ARE IN METRIC.
4. PART INCLUDES;
2x LATCHING BRACKET
1x STRAIN RELIEF BRACKET

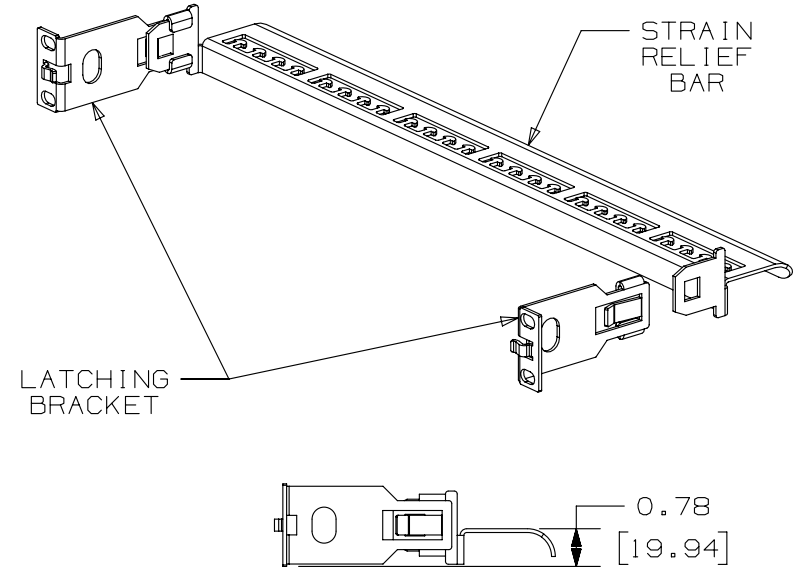
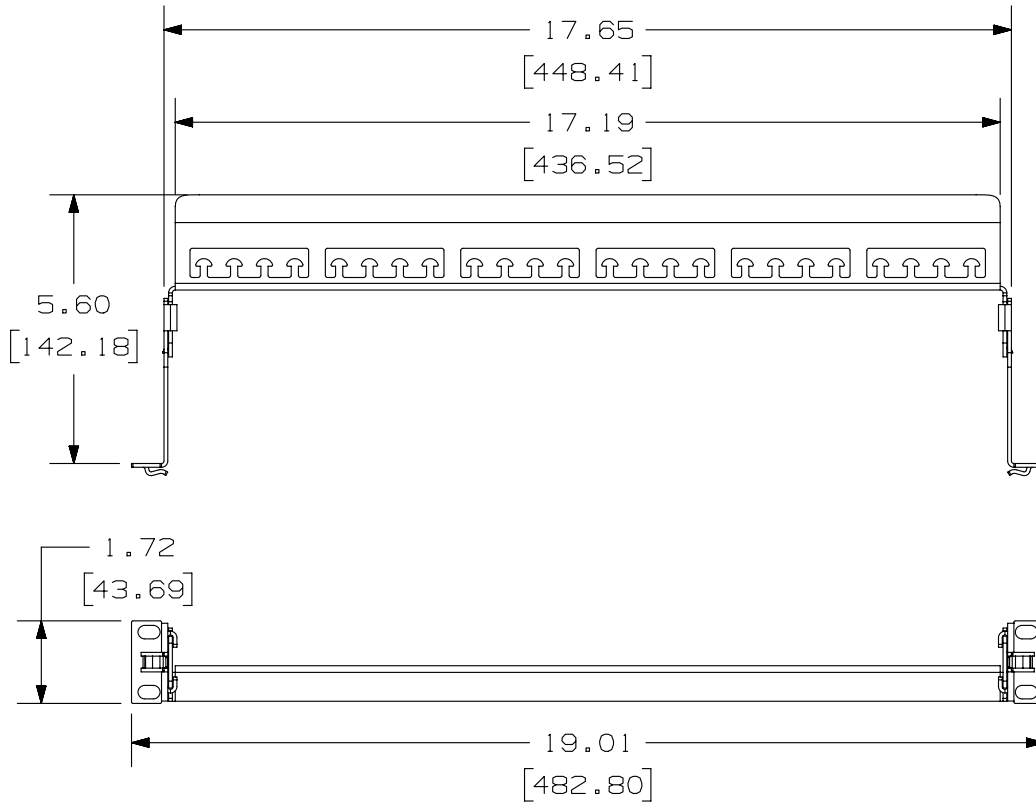

PART NUMBER	SRBPPQBRKT	PRODUCT SPEC/PKG SPEC	N/A
I.I. NUMBER	N/A	WORK INSTRUCTION	N/A

TITLE
STRAIN RELIEF BAR, PATCH PANEL MOUNTABLE WITH QUICK RELEASE BRACKET
CUSTOMER DRAWING

ITEM REVISION NAME
M00741AL/00

DATASET FILE NAME
M00741AL_DC202/00A



UNLESS OTHERWISE SPECIFIED, DIMENSIONAL TOLERANCES ARE: IN [mm]
.x ± .1 [2.54] .xxx ± .015 [.381]
.xx ± .03 [.75] ANGLES ±

MATERIAL:

DRAWING NUMBER:
00741-202

DRAWN BY	DATE	CHK	SCALE	SHT 1 OF 1	SIZE
BKA	8-22-2013	MMR	N/A		A

REV	DATE	BY	CHK	APR	DESCRIPTION	ECN
R	8-22-13	BKA	MMR	LDS	RELEASED FOR DISTRIBUTION	00741-202

D10100DA/14

2

1

2

1