



Chipsmall Limited consists of a professional team with an average of over 10 year of expertise in the distribution of electronic components. Based in Hongkong, we have already established firm and mutual-benefit business relationships with customers from,Europe,America and south Asia,supplying obsolete and hard-to-find components to meet their specific needs.

With the principle of “Quality Parts,Customers Priority,Honest Operation,and Considerate Service”,our business mainly focus on the distribution of electronic components. Line cards we deal with include Microchip,ALPS,ROHM,Xilinx,Pulse,ON,Everlight and Freescale. Main products comprise IC,Modules,Potentiometer,IC Socket,Relay,Connector.Our parts cover such applications as commercial,industrial, and automotives areas.

We are looking forward to setting up business relationship with you and hope to provide you with the best service and solution. Let us make a better world for our industry!



Contact us

Tel: +86-755-8981 8866 Fax: +86-755-8427 6832

Email & Skype: info@chipsmall.com Web: www.chipsmall.com

Address: A1208, Overseas Decoration Building, #122 Zhenhua RD., Futian, Shenzhen, China



MODEL:

SRCABLEVRT3

3" Wide Vertical Cable Manager (Double Finger Duct Type)

- A** Toolless Mounting Buttons
- B** Three Piece Design
(Split into three 2-foot sections)

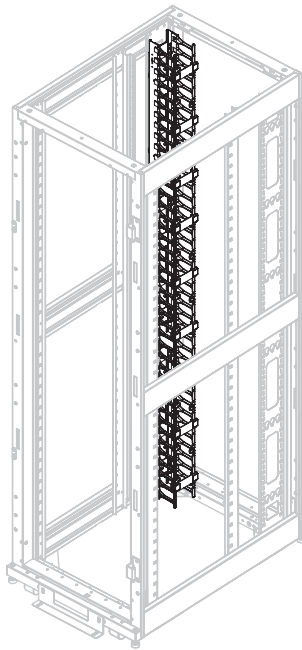

SRCABLEVRT3 organizes cables and helps eliminate cable stress. It is compatible with most standard 19" enclosures and open frame racks. Includes mounting hardware.

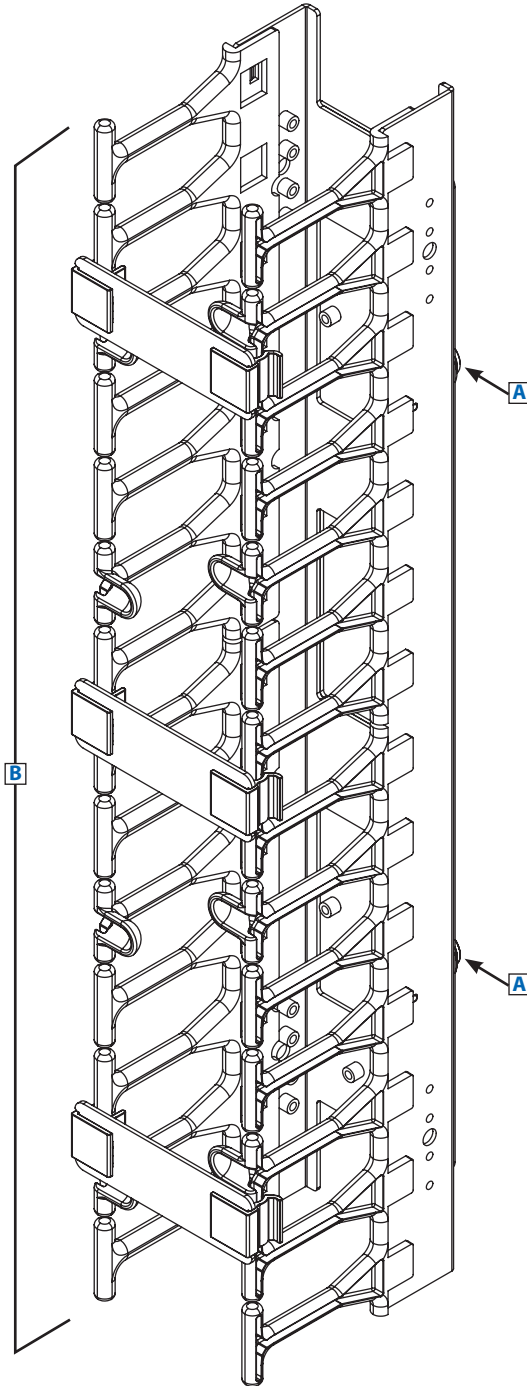

Specifications

Model	SRCABLEVRT3
Unit Dimensions (H x W x D)	4.39 x 5.31 x 24.45 in (111.5 x 135 x 621.03 mm)
Shipping Dimensions (H x W x D)	4.92 x 8.07 x 24.8 in (125 x 205 x 629.9 mm)
Unit Weight	5 lb (2.27 kg)
Shipping Weight	11 lb (4.99 kg)
Regulatory Compliance	Meets RoHS standards

Tripp Lite has a policy of continuous improvement. Specifications are subject to change without notice.



SEE NEXT PAGE FOR DETAILED UNIT MEASUREMENTS



1111 W. 35th Street
Chicago, IL 60609 USA
773.869.1234
www.tripplite.com

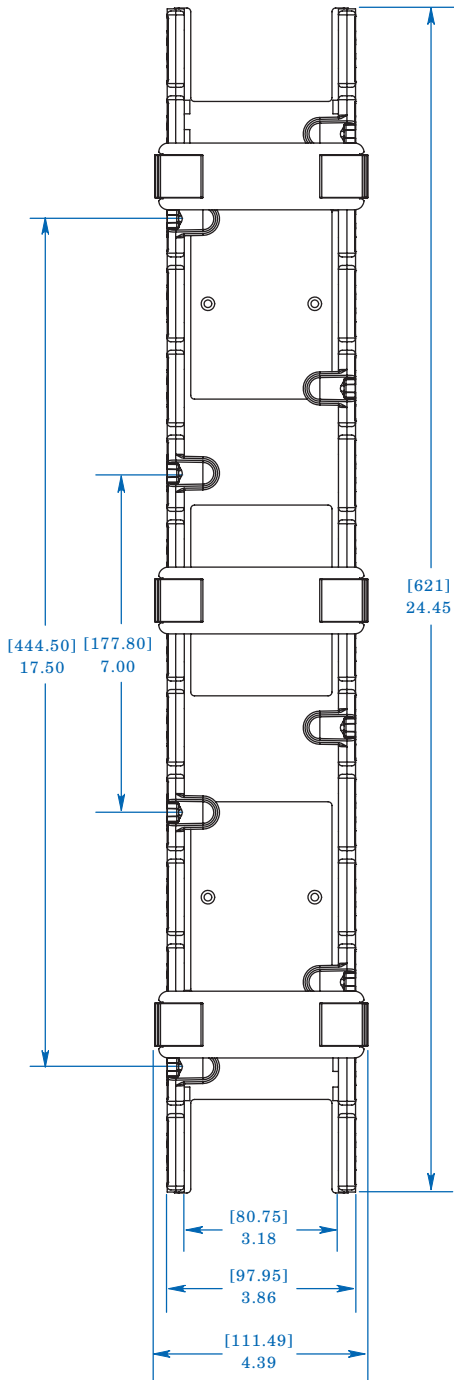

FRONT VIEW

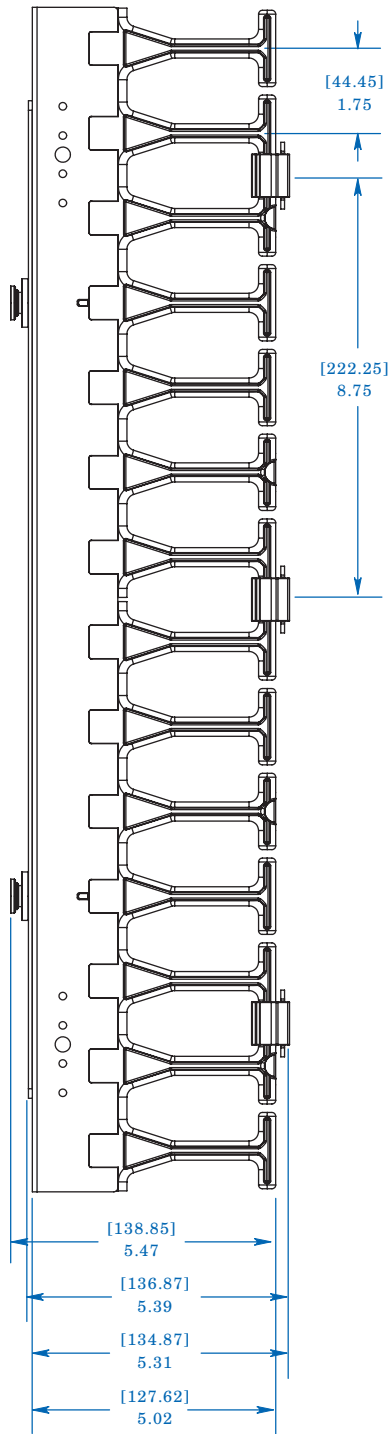

SIDE VIEW

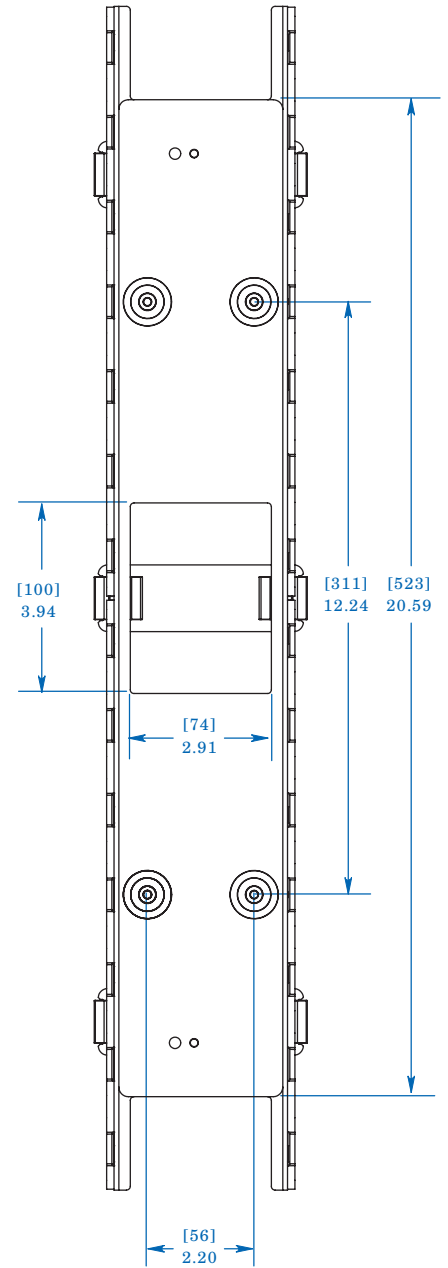

REAR VIEW

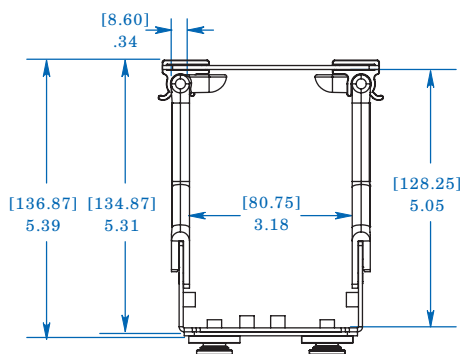

END VIEW

Dimensions: [mm] INCHES

Tripp Lite has a policy of continuous improvement. Specifications are subject to change without notice.

MODEL:
SRCABLEVRT3
TRIPP·LITE

1111 W. 35th Street
 Chicago, IL 60609 USA
 773.869.1234

www.tripplite.com