



Chipsmall Limited consists of a professional team with an average of over 10 year of expertise in the distribution of electronic components. Based in Hongkong, we have already established firm and mutual-benefit business relationships with customers from,Europe,America and south Asia,supplying obsolete and hard-to-find components to meet their specific needs.

With the principle of “Quality Parts,Customers Priority,Honest Operation,and Considerate Service”,our business mainly focus on the distribution of electronic components. Line cards we deal with include Microchip,ALPS,ROHM,Xilinx,Pulse,ON,Everlight and Freescale. Main products comprise IC,Modules,Potentiometer,IC Socket,Relay,Connector.Our parts cover such applications as commercial,industrial, and automotives areas.

We are looking forward to setting up business relationship with you and hope to provide you with the best service and solution. Let us make a better world for our industry!



Contact us

Tel: +86-755-8981 8866 Fax: +86-755-8427 6832

Email & Skype: info@chipsmall.com Web: www.chipsmall.com

Address: A1208, Overseas Decoration Building, #122 Zhenhua RD., Futian, Shenzhen, China



MODEL:

SRCASTERHDKIT

SmartRack® Heavy-Duty Rolling Caster Kit—4 Pack

SRCASTERHDKIT is a heavy-duty rolling caster kit that converts stationary rack enclosures and 4-post open frame racks into mobile rolling racks. The heavy-duty casters (750 lbs. per caster rating) allow for a weight limit of 3,000 lb., both stationary and rolling. The kit includes 4 casters and mounting hardware.

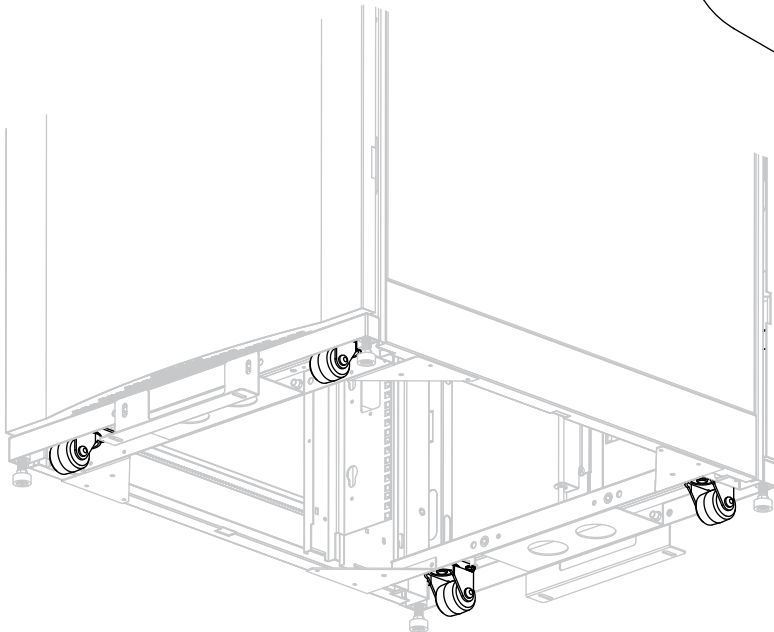
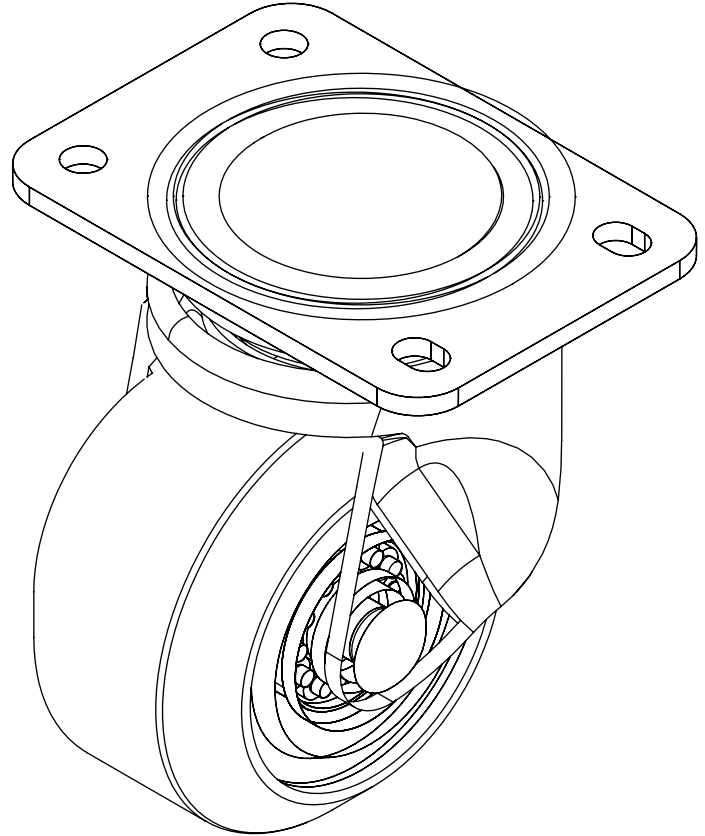

Specifications

Model	SRCASTERHDKIT
Load Rating (per caster)	750 lb. (340 kg)
Shipping Dimensions (H x W x D)	12.6 x 4.72 x 4.92 (320 x 120 x 125 mm)
Shipping Weight	6.2 lb. (2.8 kg)
Standards	Tested to RoHS

Tripp Lite has a policy of continuous improvement. Specifications are subject to change without notice.

SEE NEXT PAGE FOR DETAILED UNIT MEASUREMENTS



1111 W. 35th Street
Chicago, IL 60609 USA
773.869.1234
www.tripplite.com

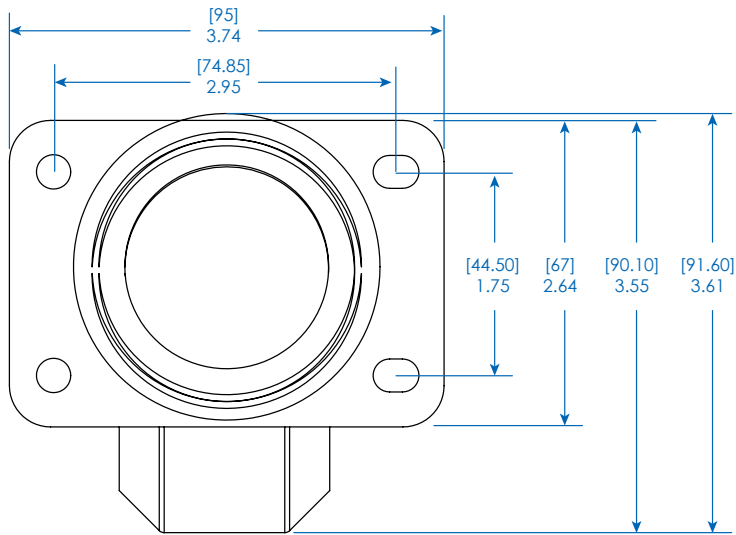

TOP VIEW

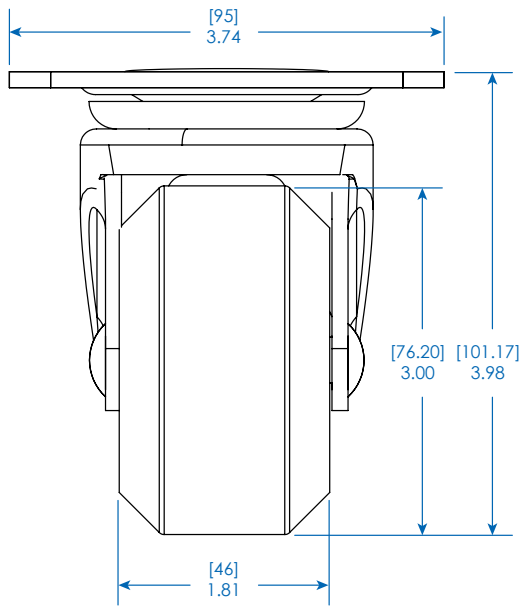

FRONT VIEW

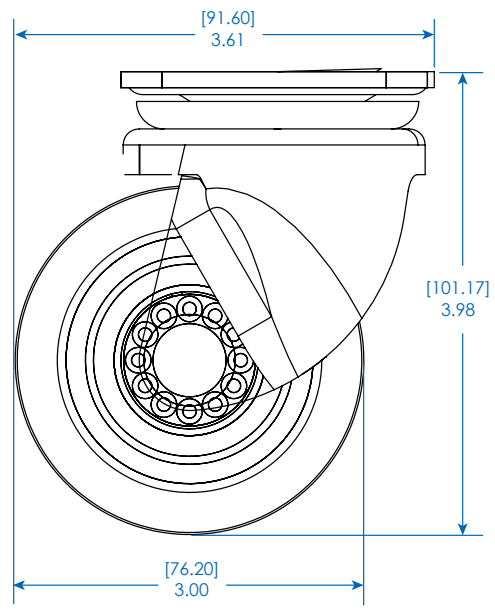

SIDE VIEW

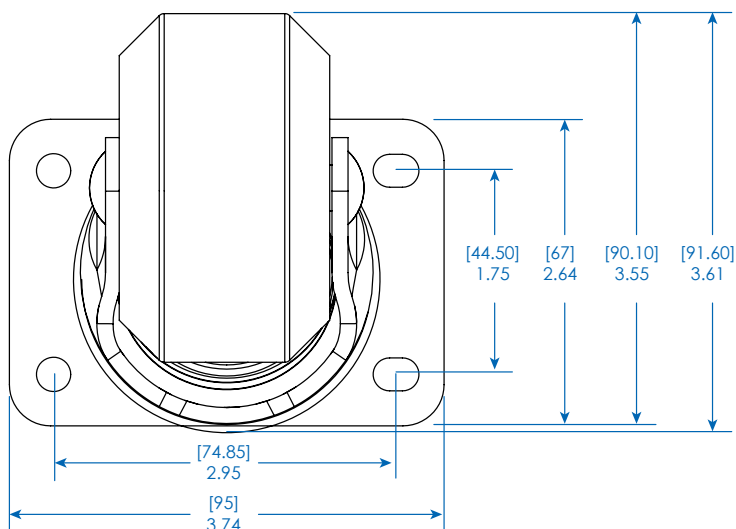

BOTTOM VIEW

MODEL:
SRCASTERHDKIT



1111 W. 35th Street
Chicago, IL 60609 USA
773.869.1234
www.tripplite.com

Dimensions: [mm] INCHES

Tripp Lite has a policy of continuous improvement. Specifications are subject to change without notice.