



Chipsmall Limited consists of a professional team with an average of over 10 year of expertise in the distribution of electronic components. Based in Hongkong, we have already established firm and mutual-benefit business relationships with customers from,Europe,America and south Asia,supplying obsolete and hard-to-find components to meet their specific needs.

With the principle of "Quality Parts,Customers Priority,Honest Operation,and Considerate Service",our business mainly focus on the distribution of electronic components. Line cards we deal with include Microchip,ALPS,ROHM,Xilinx,Pulse,ON,Everlight and Freescale. Main products comprise IC,Modules,Potentiometer,IC Socket,Relay,Connector.Our parts cover such applications as commercial,industrial, and automotives areas.

We are looking forward to setting up business relationship with you and hope to provide you with the best service and solution. Let us make a better world for our industry!



## Contact us

Tel: +86-755-8981 8866 Fax: +86-755-8427 6832

Email & Skype: info@chipsmall.com Web: www.chipsmall.com

Address: A1208, Overseas Decoration Building, #122 Zhenhua RD., Futian, Shenzhen, China



THIS COPY IS PROVIDED ON A RESTRICTED BASIS AND IS NOT TO BE USED IN ANY WAY DETRIMENTAL TO THE INTERESTS OF PANDUIT CORP.

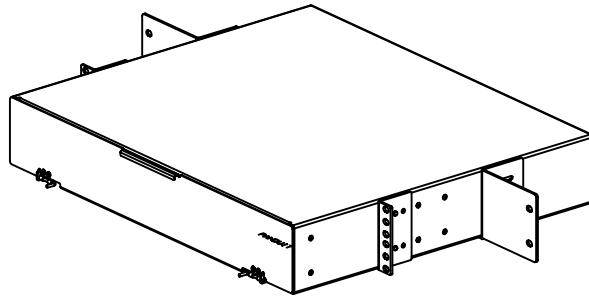

ENCLOSURE HOUSING

AREA FOR MOUSE WHEN KEYBOARD IS RETRACTED

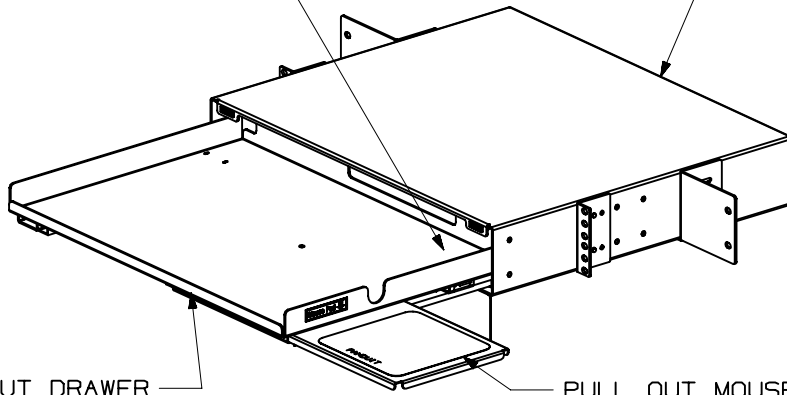

PULL OUT DRAWER

PULL OUT MOUSE TRAY PAD

NOTES:

1. SEE CATALOG FOR COMPLETE LIST OF PARTS APPLICABLE FOR USE WITH THIS PART.
2. DIMENSIONS IN PARENTHESES ARE IN METRIC.
3. KEYBOARD/MONITOR SHELF ENCLOSURE:
  - A, ENCLOSURE MOUNTS TO A STANDARD EIA 23" RACK AND USES 2 RACK UNITS (3.50") OF SPACE.
  - B, ENCLOSURE CAN BE FLUSH MOUNTED FOR INCABINET MOUNTING OR MOUNTED 5" EXTENDED FROM FRONT FACE OF UNIT (AS SHOWN).
  - C, KEYBOARD TRAY IS SUPPLIED WITH A PULL OUT MOUSE TRAY PAD MOUNTED ON THE RIGHT SIDE.
  - D, KEYBOARD TRAY WILL SUPPORT A STANDARD SIZE 20.75" LONG X 9.00" WIDE KEYBOARD.
  - E, ENCLOSURE AND ALL MAIN COMPONENTS ARE MADE OF HEAVY GAUGE ALUMINUM.
  - F, PULL OUT KEYBOARD DRAWER HAS 3/4 EXTENSION HEAVY DUTY BALL BEARING SLIDES.
  - G, ENCLOSURE FRONT DOOR SWINGS DOWN 180° AND IS REMOVABLE.
  - H, ENCLOSURE AND ALL COMPONENTS ARE PAINTED TEXTURED BLACK.
  - I, ENCLOSURE IS SUPPLIED WITH MOUNTING BRACKETS, HARDWARE KIT AND FULL SIZE KEYBOARD WRIST PAD (NOT SHOWN).
  - J, TOP SURFACE OF ENCLOSURE WILL SUPPORT 200 POUNDS.

PANDUIT PART NUMBER: SRM23MK2				WEIGHT: 15.20 LB PER UNIT 6895 G PER UNIT				CAD FILENAME/LAYERS: M10007AA_DC_03A.PRT					
								<h1 style="margin: 0;">PANDUIT</h1> <p style="margin: 0;">CORP. TINLEY PARK, ILLINOIS</p>					
								<p style="margin: 0;">KEYBOARD/MONITOR SHELF ENCLOSURE</p> <p style="margin: 0;">SRM23MK2</p> <p style="margin: 0;">CUSTOMER DRAWING</p>					
								UNLESS OTHERWISE SPECIFIED, DIMENSIONAL TOLERANCES ARE:		UNLESS OTHERWISE SPECIFIED, ALL DIMENSIONS ARE GIVEN IN INCHES, THIRD ANGLE PROJECTION.			
								(.X) ± .03 (.XXX) ± .005 (.XX) ± .01 ANGLES ± 1°		SCALE: 1:8			
R 3-28-01 JsP				RELEASED FOR PRODUCTION				10007-29		DRAWN BY: JsP		MAT'L: SEE NOTES	
REV DATE BY CHK				DESCRIPTION				ECN - R CUST SUP OTH		DATE: 3-28-01		DRAWING NO. 10007-29 SHT 1 OF 2	
										CHK'D		DWG SIZE: A	

THIS COPY IS PROVIDED ON A RESTRICTED BASIS AND IS NOT TO BE USED IN ANY WAY DETRIMENTAL TO THE INTERESTS OF PANDUIT CORP.

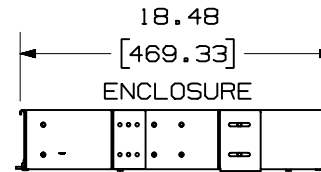
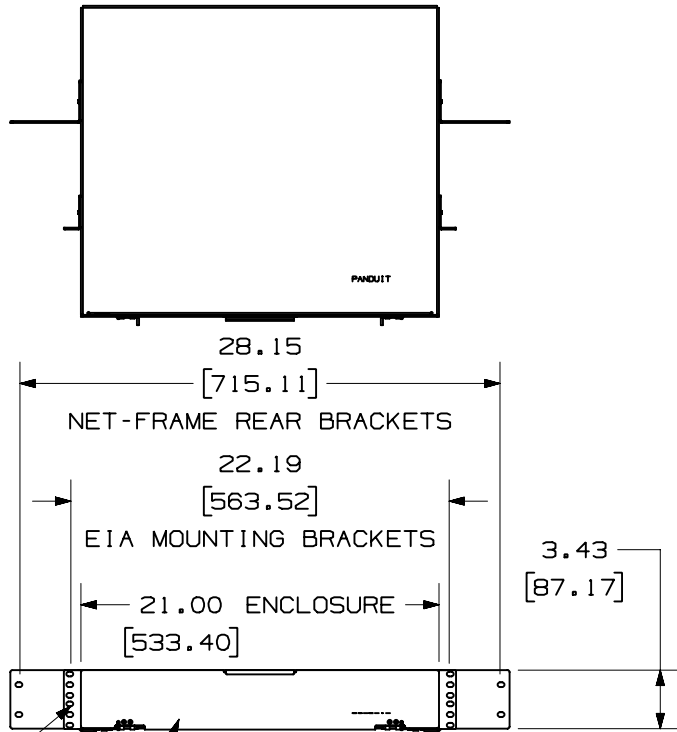

DOOR - REMOVABLE  
 STANDARD EIA SPACING MOUNTING BRACKETS  
 (4) SUPPLIED WITH ENCLOSURE

CAD FILENAME/LAYERS M10007AA\_DC\_03A.PRT

REV	DATE	BY	CHK	DESCRIPTION	ECN	R	CUST	SUP	OTH
R	3-28-01	JSP		RELEASED FOR PRODUCTION	10007-29				

**PANDUIT** CORP. TINLEY PARK, ILLINOIS  
 KEYBOARD/MONITOR SHELF ENCLOSURE  
 SRM23MK2  
 CUSTOMER DRAWING

UNLESS OTHERWISE SPECIFIED, DIMENSIONAL TOLERANCES ARE: (.X) ± .03 (.XXX) ± .005 (.XX) ± .01 ANGLES ± 1°		UNLESS OTHERWISE SPECIFIED, ALL DIMENSIONS ARE GIVEN IN INCHES, THIRD ANGLE PROJECTION.	
DRAWN BY JSP	MAT'L:	SCALE NONE	
DATE 3-28-01	SEE NOTES	DRAWING NO. 10007-29	DWG A
CHK'D		SHT 2 OF 2	SIZE