



Chipsmall Limited consists of a professional team with an average of over 10 year of expertise in the distribution of electronic components. Based in Hongkong, we have already established firm and mutual-benefit business relationships with customers from,Europe,America and south Asia,supplying obsolete and hard-to-find components to meet their specific needs.

With the principle of "Quality Parts,Customers Priority,Honest Operation,and Considerate Service",our business mainly focus on the distribution of electronic components. Line cards we deal with include Microchip,ALPS,ROHM,Xilinx,Pulse,ON,Everlight and Freescale. Main products comprise IC,Modules,Potentiometer,IC Socket,Relay,Connector.Our parts cover such applications as commercial,industrial, and automotives areas.

We are looking forward to setting up business relationship with you and hope to provide you with the best service and solution. Let us make a better world for our industry!



## Contact us

Tel: +86-755-8981 8866 Fax: +86-755-8427 6832

Email & Skype: info@chipsmall.com Web: www.chipsmall.com

Address: A1208, Overseas Decoration Building, #122 Zhenhua RD., Futian, Shenzhen, China



MODEL:

# SRSHELF4PSLHD

## Heavy-Duty Sliding Shelf for 4-Post Racks



200 lb.  
Load Capacity



28.3 in. Depth



Sturdy Steel  
Construction



Fully Extendable  
Shelf

- A** 28.3-inch Shelf Depth
  - B** Extendable Ball Bearing Slide Mounting Rails
  - C** Mounting Brackets
  - D** Cold-Rolled Steel Construction
- Also includes shelf mounting hardware.

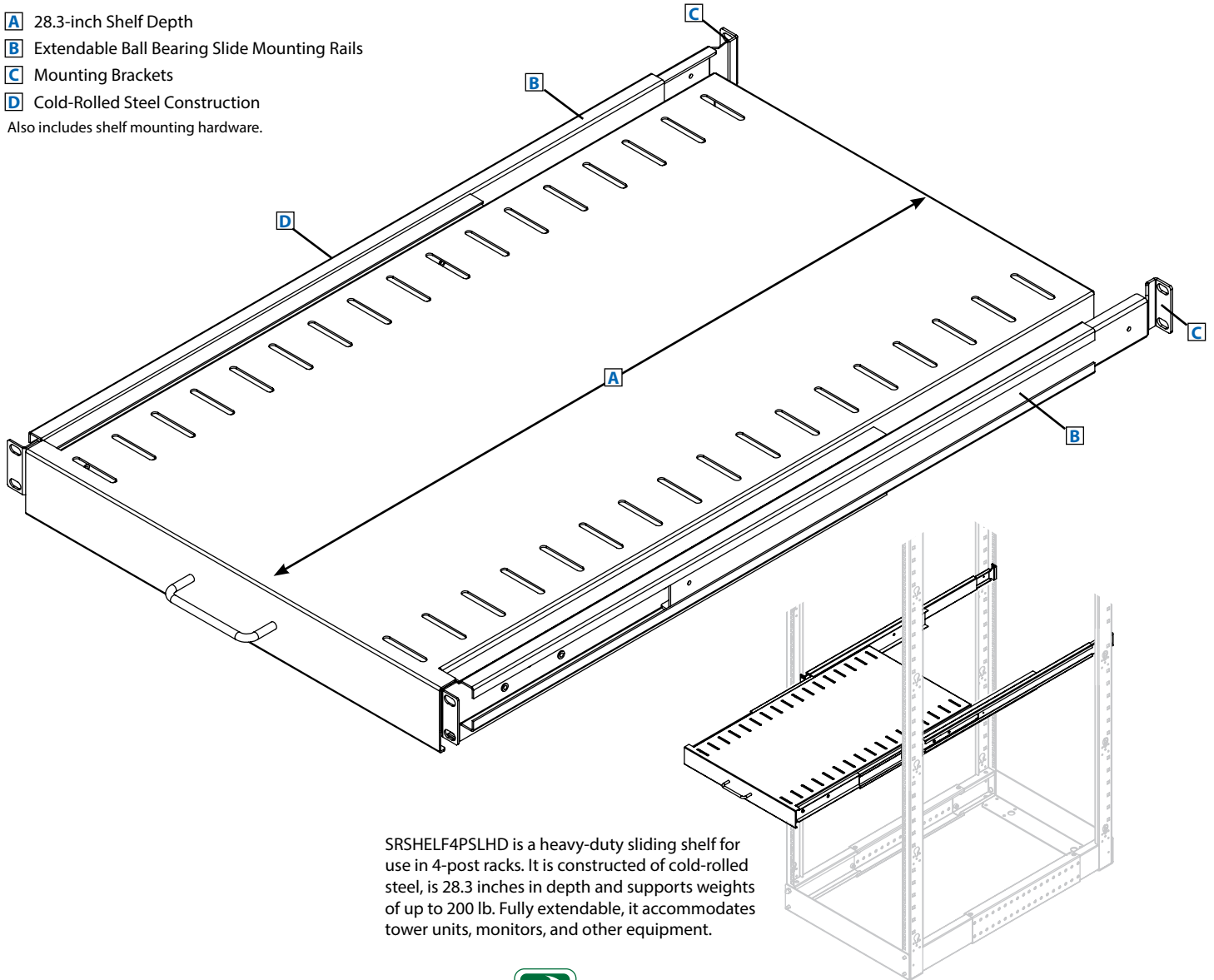

SRSHELF4PSLHD is a heavy-duty sliding shelf for use in 4-post racks. It is constructed of cold-rolled steel, is 28.3 inches in depth and supports weights of up to 200 lb. Fully extendable, it accommodates tower units, monitors, and other equipment.

### Specifications

Model	SRSHELF4PSLHD
Load Rating	200 lb (91 kg)
Unit Dimensions (H x W x D)	2.36 x 18.98 x 30.11 in. (60 x 482 x 765 mm)
Shipping Dimensions (H x W x D)	3 x 20 x 31 in. (76 x 508 x 787 mm)
Unit Weight	22 lb (10 kg)
Shipping Weight	24 lb (11 kg)
Standards	Tested to RoHS and GOST

Tripp Lite has a policy of continuous improvement. Specifications are subject to change without notice.



SEE NEXT PAGE FOR DETAILED UNIT MEASUREMENTS



1111 W. 35th Street  
Chicago, IL 60609 USA  
773.869.1234  
www.tripplite.com

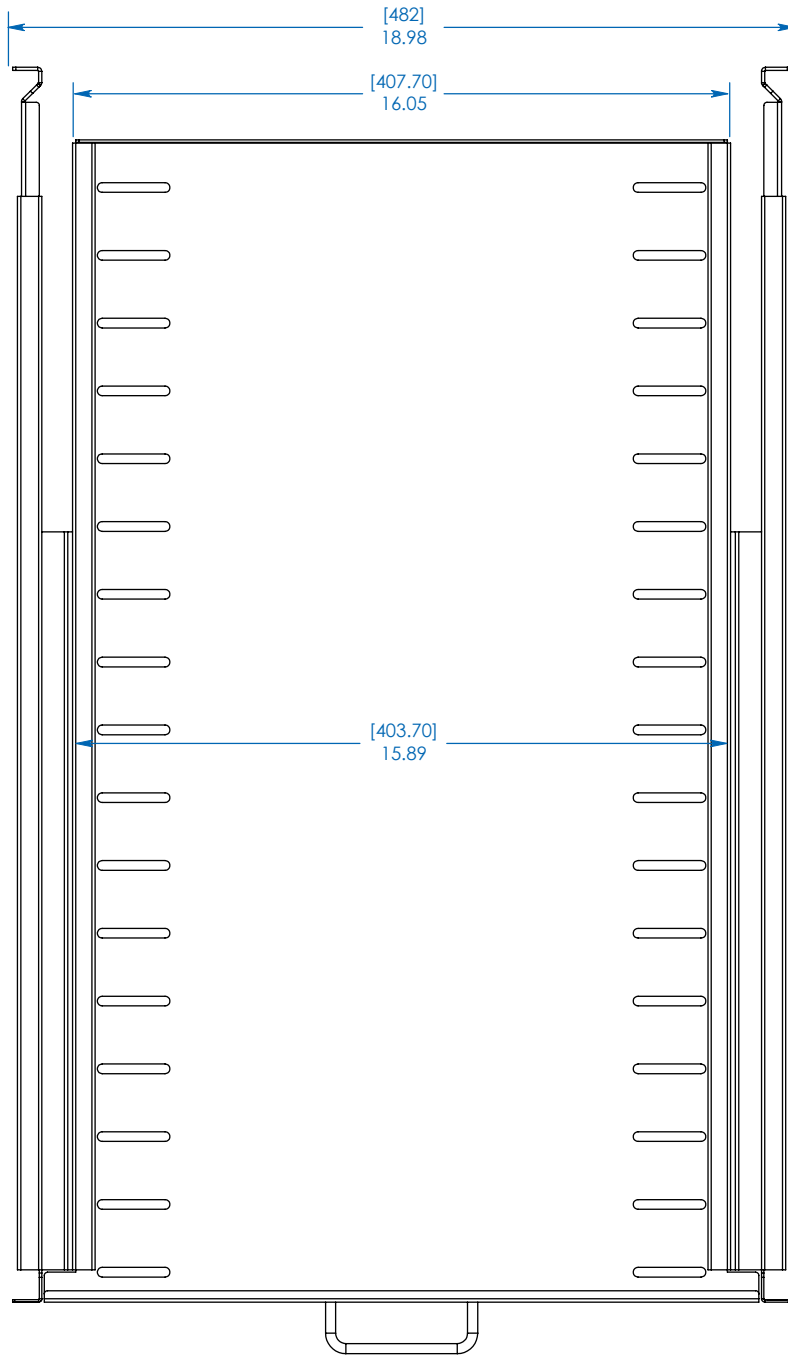

TOP VIEW

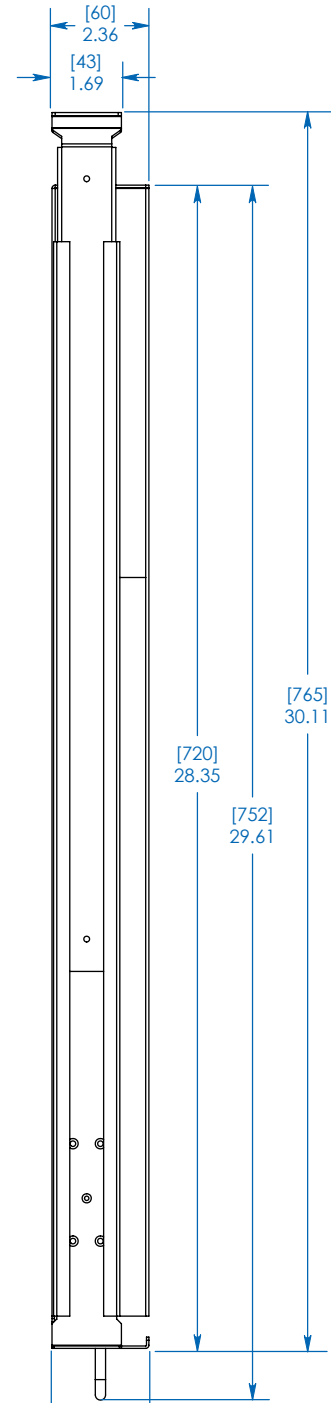

SIDE VIEW

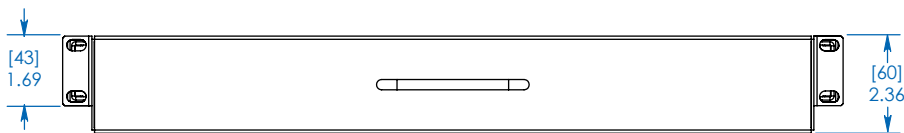

FRONT VIEW

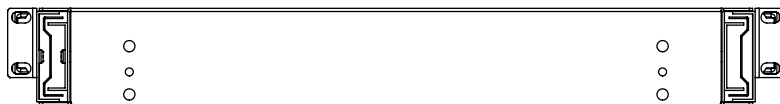

REAR VIEW

MODEL:  
**SRSHELF4PSLHD**



1111 W. 35th Street  
Chicago, IL 60609 USA  
773.869.1234

[www.tripplite.com](http://www.tripplite.com)

Dimensions: [mm] INCHES

Tripp Lite has a policy of continuous improvement. Specifications are subject to change without notice.