



Chipsmall Limited consists of a professional team with an average of over 10 year of expertise in the distribution of electronic components. Based in Hongkong, we have already established firm and mutual-benefit business relationships with customers from,Europe,America and south Asia,supplying obsolete and hard-to-find components to meet their specific needs.

With the principle of “Quality Parts,Customers Priority,Honest Operation,and Considerate Service”,our business mainly focus on the distribution of electronic components. Line cards we deal with include Microchip,ALPS,ROHM,Xilinx,Pulse,ON,Everlight and Freescale. Main products comprise IC,Modules,Potentiometer,IC Socket,Relay,Connector.Our parts cover such applications as commercial,industrial, and automotives areas.

We are looking forward to setting up business relationship with you and hope to provide you with the best service and solution. Let us make a better world for our industry!



## Contact us

Tel: +86-755-8981 8866 Fax: +86-755-8427 6832

Email & Skype: info@chipsmall.com Web: www.chipsmall.com

Address: A1208, Overseas Decoration Building, #122 Zhenhua RD., Futian, Shenzhen, China



MODELS:

# SRW18US13 / SRW18US13G

## SmartRack® Slim Wall-Mount Rack Enclosure Cabinets



18 Rack Units



250 lb.  
Load Rating



Sturdy Steel  
Construction



Locking Doors  
& Side Panels



Clear Acrylic  
Front Window  
(SRW18US13G only)



Hinged Wall  
Bracket



Standard  
19" Rack Width



Convenient  
Cable Access



Adjustable  
Mounting Rails



Ventilated for  
Ample Airflow



Reversible  
Cabinet

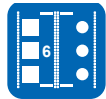

Square/  
Threaded Hole  
Mounting

- A** Front Door  
(Lockable/Removable/Reversible.  
SRW18US13 door is perforated;  
SRW18US13G door has a clear acrylic window.)
- B** Adjustable Mounting Rails (4)  
(Support square and threaded hole mounting options.)
- C** Side Panels (2)  
(Lockable/Removable)
- D** Hinged Wall Bracket  
(Lockable/Reversible. Allows the cabinet to  
swing away from the wall for convenient rear  
access to equipment and cabling.)
- E** Cable Access Port Covers (4)  
(Removable)
- F** Ventilation Fan Ports (4)  
(Support optional SRFANWM fan kit.)
- G** Keys (2)

Also Includes: Owner's manual, cabinet ground screw,  
pre-installed front door ground wire and rack-mount  
equipment mounting hardware (42 cage nuts,  
42 mounting screws, 42 #12-24 screws, 42 washers).

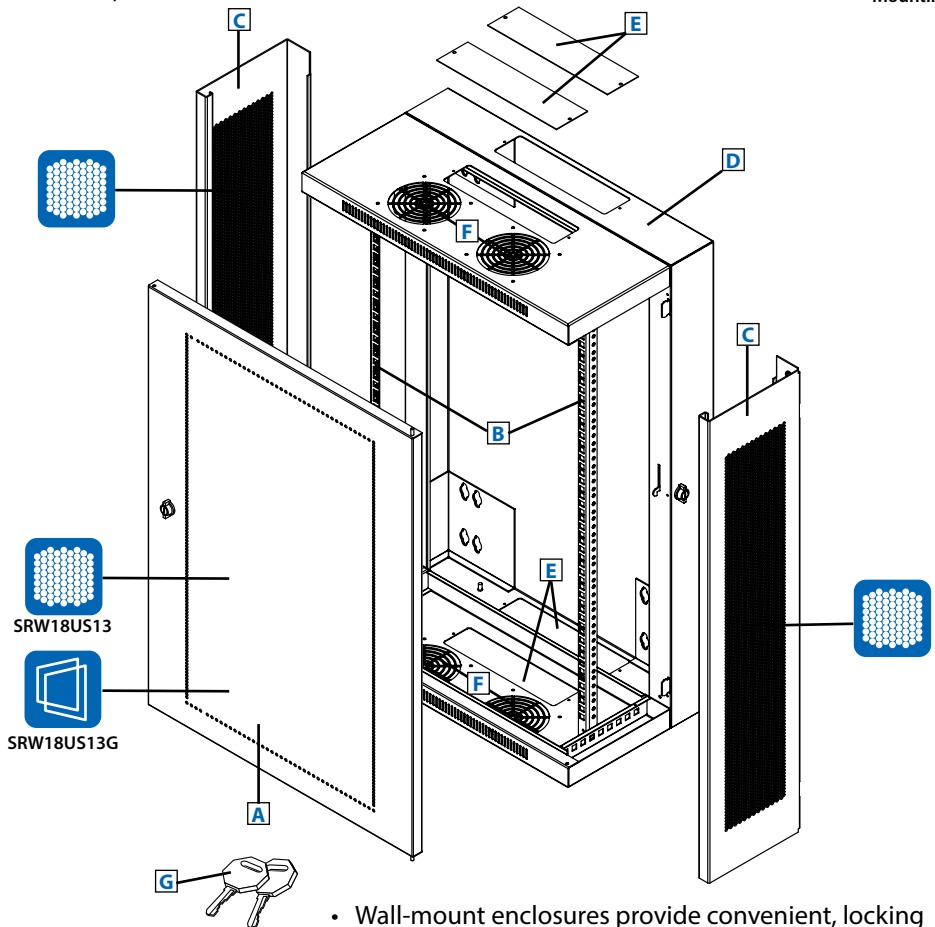

- Wall-mount enclosures provide convenient, locking storage for rack-mount IT devices and other equipment that should be off the floor, out of the way and secure
- The cabinet is fully reversible, allowing installers to change door hinges from left to right by simply rotating the unit 180 degrees before mounting
- Hinged wall bracket allows cabinet to swing away from the wall for convenient access to equipment and cabling

**SEE NEXT PAGE FOR DETAILED UNIT MEASUREMENTS**

### Specifications

Model	SRW18US13 / SRW18US13G
Rack Spaces	18U
Equipment Mounting Depth	Up to 13 in. (330 mm)
Load Rating*	250 lb. (113 kg)
Unit Dimensions [H x W x D]	35.61 x 23.62 x 13 in. (904.6 x 600 x 330.2 mm)
Shipping Dimensions [H x W x D]	41.61 x 25.6 x 14.96 in. (1056.9 x 650.2 x 380 mm)
Unit Weight	83.77 lb. (38 kg)
Shipping Weight	98 lb. (44.5 kg)
Standards	Tested to UL/CSA 60950-1, IEC 60297-3-100, RoHS, NOM (Mexico), EIA/ECA-310-E, GOST; PCI Compliant, IP20 Protection Rating

\* The load rating includes the combined weight of the unit and installed equipment. The unit must be mounted to a stable surface with user-supplied anchors capable of bearing the full load.



1111 W. 35th Street  
Chicago, IL 60609 USA  
773.869.1234  
www.tripplite.com

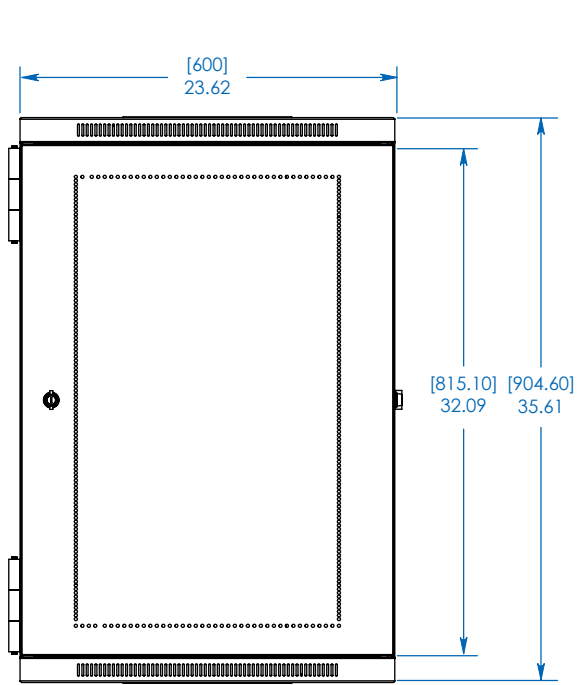

FRONT VIEW

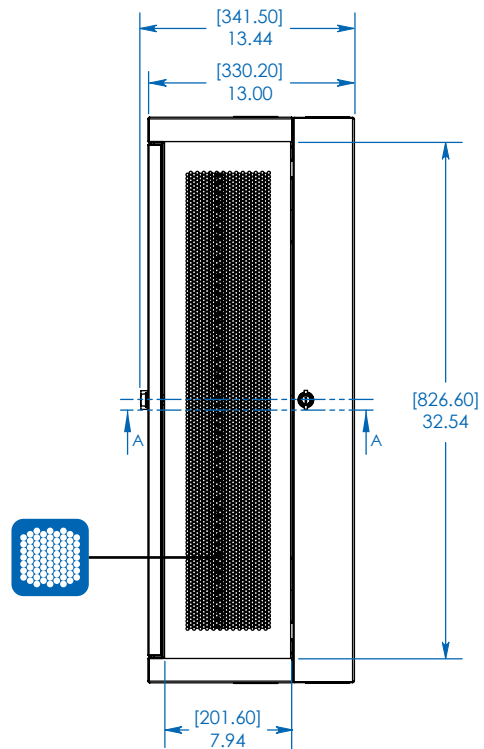

SIDE VIEW

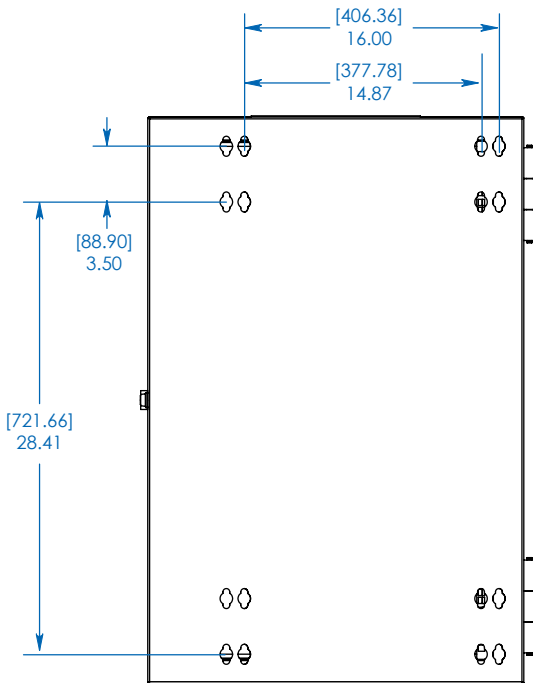

REAR VIEW

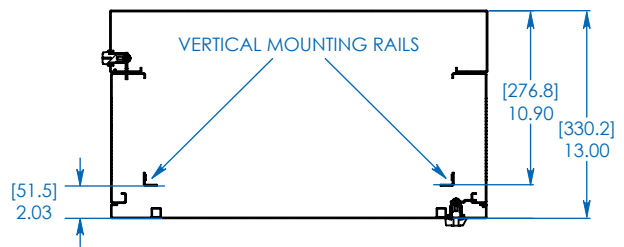

CROSS-SECTION A:  
CLEARANCE IN FRONT OF AND BEHIND  
VERTICAL MOUNTING RAILS  
(RAILS AT DEFAULT POSITION)

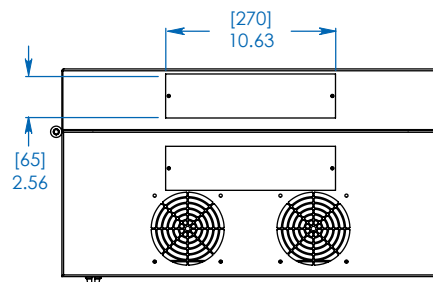

TOP/BOTTOM VIEW

MODELS:

**SRW18US13 /  
SRW18US13G**



Dimensions: [mm] INCHES

Tripp Lite has a policy of continuous improvement. Specifications are subject to change without notice.

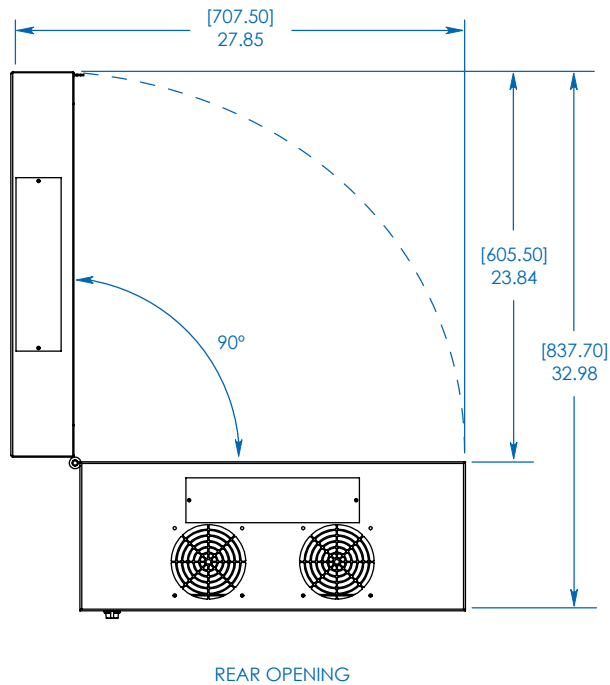
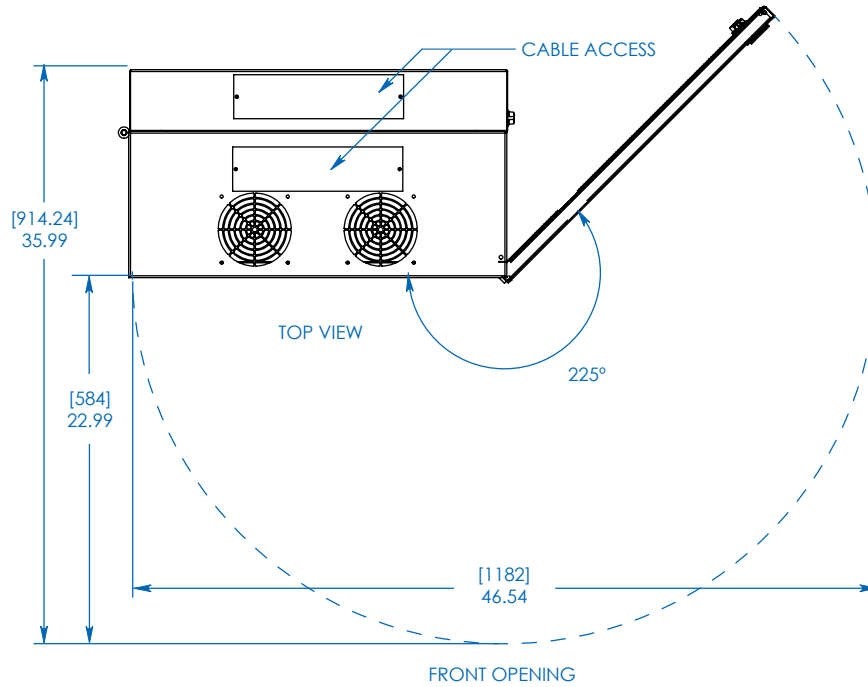

MODELS:  
**SRW18US13 /  
 SRW18US13G**



1111 W. 35th Street  
 Chicago, IL 60609 USA  
 773.869.1234  
 www.tripplite.com

Dimensions: [mm] INCHES

Tripp Lite has a policy of continuous improvement. Specifications are subject to change without notice.