



Chipsmall Limited consists of a professional team with an average of over 10 year of expertise in the distribution of electronic components. Based in Hongkong, we have already established firm and mutual-benefit business relationships with customers from,Europe,America and south Asia,supplying obsolete and hard-to-find components to meet their specific needs.

With the principle of “Quality Parts,Customers Priority,Honest Operation,and Considerate Service”,our business mainly focus on the distribution of electronic components. Line cards we deal with include Microchip,ALPS,ROHM,Xilinx,Pulse,ON,Everlight and Freescale. Main products comprise IC,Modules,Potentiometer,IC Socket,Relay,Connector.Our parts cover such applications as commercial,industrial, and automotives areas.

We are looking forward to setting up business relationship with you and hope to provide you with the best service and solution. Let us make a better world for our industry!



Contact us

Tel: +86-755-8981 8866 Fax: +86-755-8427 6832

Email & Skype: info@chipsmall.com Web: www.chipsmall.com

Address: A1208, Overseas Decoration Building, #122 Zhenhua RD., Futian, Shenzhen, China



MODEL:

SRW6UW

SmartRack® White Wall-Mount Rack Enclosure Cabinet



6 Rack Units



200 lb.
Load Rating



Sturdy Steel
Construction



Locking Doors
& Side Panels



Standard
19" Rack Width



Convenient
Cable Access



Adjustable
Mounting Rails



Ventilated for
Ample Airflow



Reversible
Cabinet

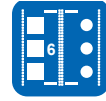

Square/Threaded
Hole Mounting

- A** Front Door
(Lockable/Removable/Reversible)
- B** Adjustable Mounting Rails (2)
- C** Side Panels (2)
(Lockable/Removable)
- D** Mounting Plate
(Removable. Includes mounting
hooks for cabinet.)
- E** Cable Access Port Covers (2)
(Removable)
- F** Ventilation Fan Ports (4)
(Support optional SRFANWM fan kit.)
- G** Keys (2)

Also Includes: Owner's manual, mounting plate screws (3), cabinet ground screw, pre-installed front door ground wire and rackmount equipment mounting hardware (12 cage nuts, 12 mounting screws, 12 nylon cup washers).

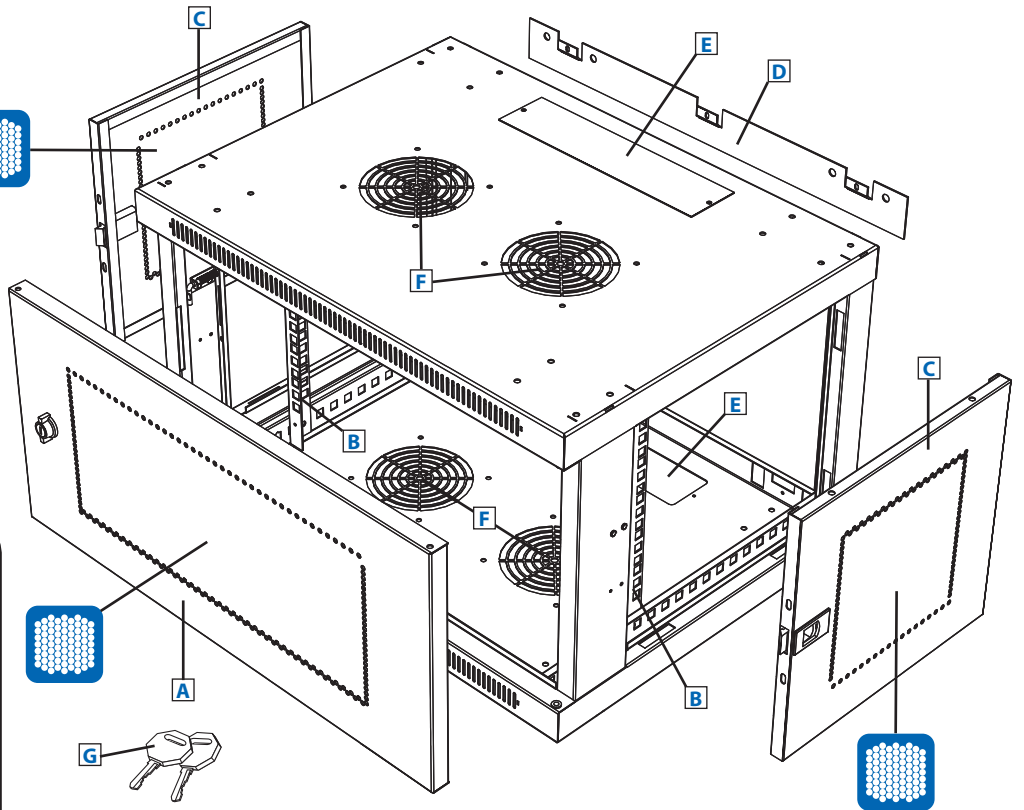
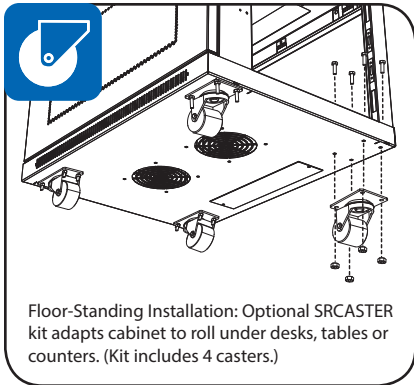

- Wall-mount enclosures provide convenient, locking storage for rackmount IT devices and other equipment that should be off the floor, out of the way and secure
- The cabinet is fully reversible, allowing installers to change door hinges from left to right by simply rotating the unit 180 degrees before mounting

SEE NEXT PAGE FOR DETAILED UNIT MEASUREMENTS



1111 W. 35th Street
Chicago, IL 60609 USA
773.869.1234
www.tripplite.com

Specifications

Model	SRW6UW
Rack Spaces	6U
Equipment Mounting Depth	Up to 16.5 in. / 419 mm
Load Rating*	200 lb. / 90.7 kg
Unit Dimensions (H x W x D)	14.5 x 23.63 x 17.5 in. / 368 x 600.2 x 445 mm
Shipping Dimensions (H x W x D)	17.5 x 26.5 x 20.5 in. / 445 x 673 x 521 mm
Unit Weight	29 lb. / 13.2 kg
Shipping Weight	32 lb. / 14.5 kg
Standards	Tested to EIA/ECA-310-E, UL/CSA 60950-1, NOM (Mexico), RoHS

* The load rating includes the combined weight of the unit and installed equipment. The unit must be mounted to a stable surface with user-supplied anchors capable of bearing the full load.



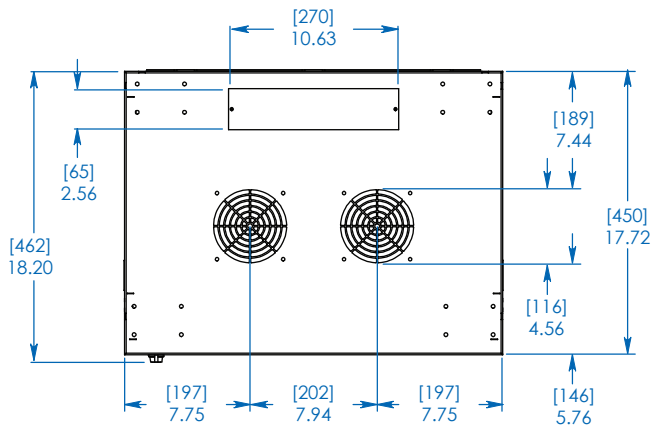

TOP/BOTTOM VIEW

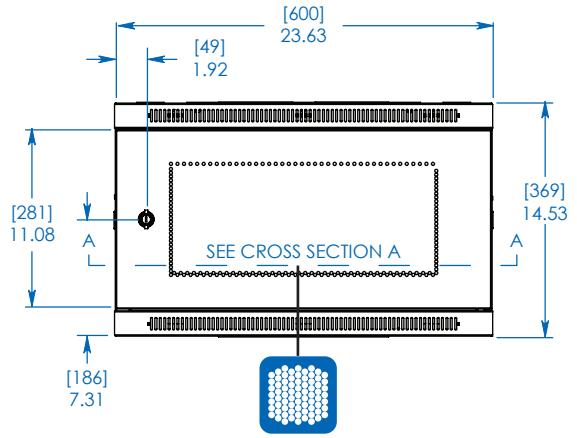

FRONT VIEW

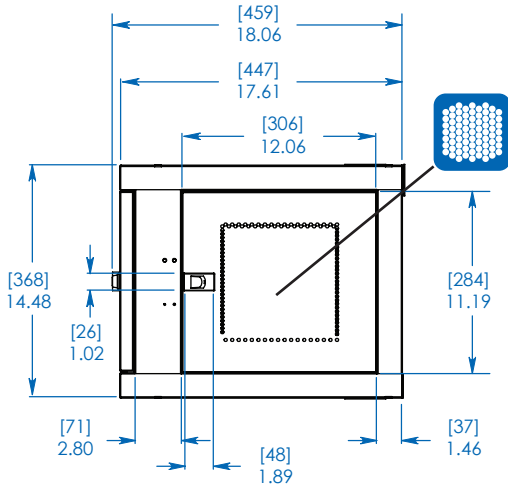

SIDE VIEW

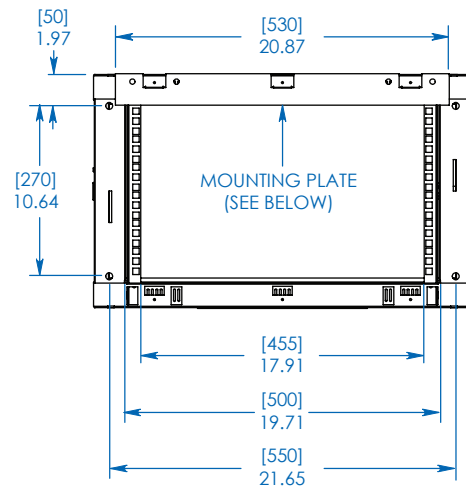

REAR VIEW (FRONT DOOR NOT SHOWN)

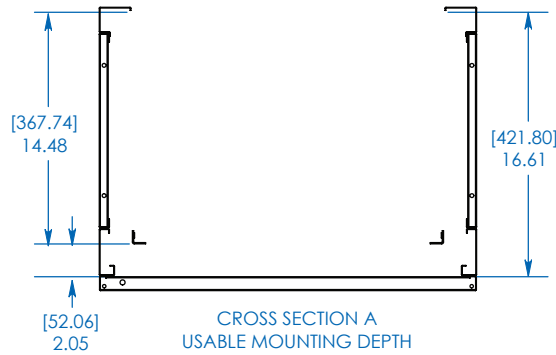

CROSS SECTION A
USABLE MOUNTING DEPTH

Dimensions: [mm] INCHES

Tripp Lite has a policy of continuous improvement. Specifications are subject to change without notice.

MODEL:
SRW6UW
TRIPP·LITE

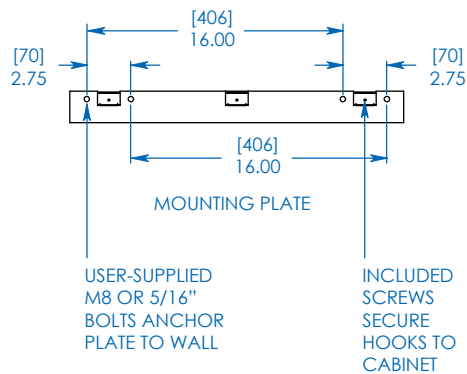
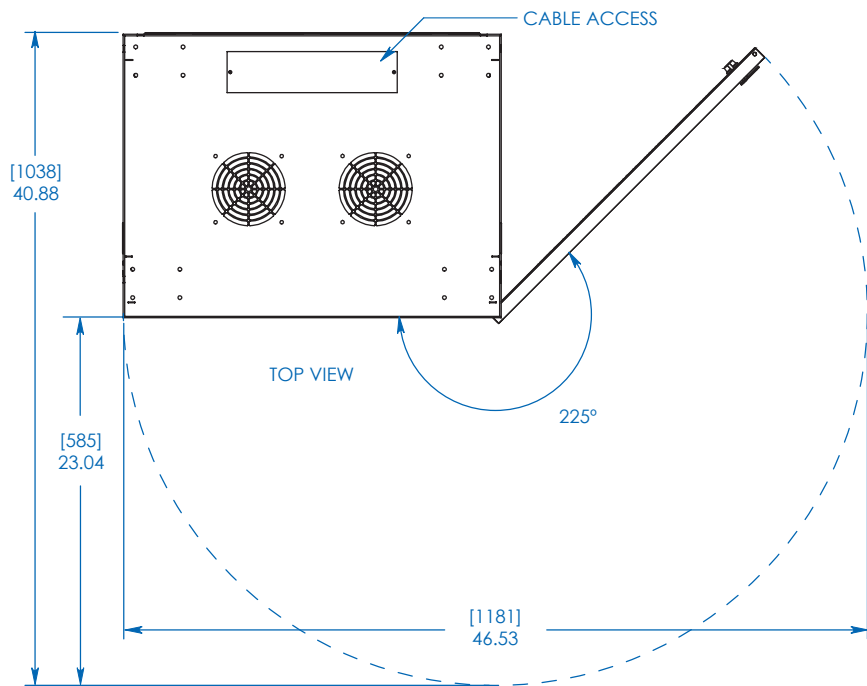

Dimensions: [mm] INCHES

Tripp Lite has a policy of continuous improvement. Specifications are subject to change without notice.

MODEL:
SRW6UW

TRIPP·LITE

1111 W. 35th Street
Chicago, IL 60609 USA
773.869.1234
www.tripplite.com