



Chipsmall Limited consists of a professional team with an average of over 10 year of expertise in the distribution of electronic components. Based in Hongkong, we have already established firm and mutual-benefit business relationships with customers from,Europe,America and south Asia,supplying obsolete and hard-to-find components to meet their specific needs.

With the principle of “Quality Parts,Customers Priority,Honest Operation,and Considerate Service”,our business mainly focus on the distribution of electronic components. Line cards we deal with include Microchip,ALPS,ROHM,Xilinx,Pulse,ON,Everlight and Freescale. Main products comprise IC,Modules,Potentiometer,IC Socket,Relay,Connector.Our parts cover such applications as commercial,industrial, and automotives areas.

We are looking forward to setting up business relationship with you and hope to provide you with the best service and solution. Let us make a better world for our industry!



Contact us

Tel: +86-755-8981 8866 Fax: +86-755-8427 6832

Email & Skype: info@chipsmall.com Web: www.chipsmall.com

Address: A1208, Overseas Decoration Building, #122 Zhenhua RD., Futian, Shenzhen, China



MODEL:

SRWF2U36

SmartRack® Low-Profile Wall-Mount Rack Enclosure Cabinet



2 Rack Units



2U Patch Panel Bracket



150 lb. Load Rating



Sturdy Steel Construction



Locking Door



Accommodates Standard 19-inch Equipment



Convenient Cable Access



Adjustable Mounting Rails



Ventilated for Ample Airflow



Reversible Door

- A** Front Door (Lockable/Reversible)
- B** Horizontal Mounting Rails (Adjustable/Reversible)
- C** Vertical Mounting Brackets
- D** 2U Slide-Out Patch Panel Mounting Brackets
- E** Cable Access Holes
- F** Vents
- G** Wall-Mounting Slots
- H** Keys

Also Includes: Owner's Manual and rackmount equipment mounting hardware (12 M6 screws, 12 M6 cup washers and 12 12-24 screws).

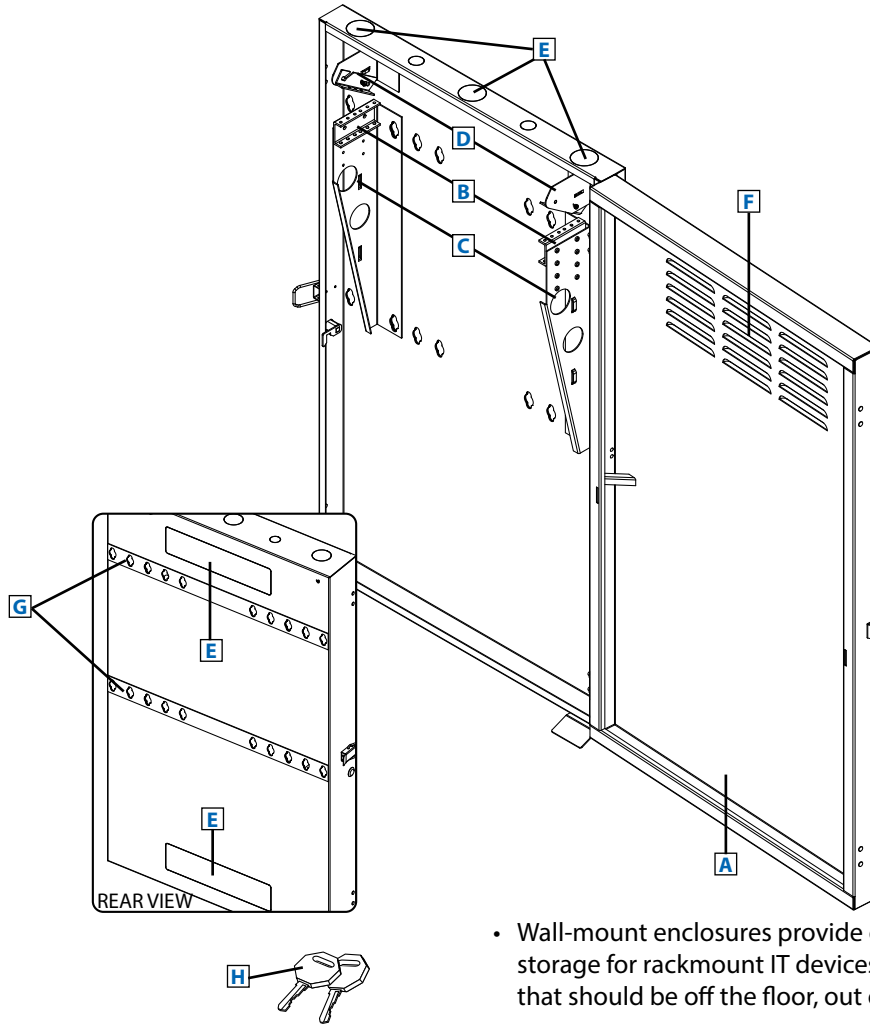

- Wall-mount enclosures provide convenient, locking storage for rackmount IT devices and other equipment that should be off the floor, out of the way and secure
- Low-profile design with vertical equipment mounting is ideal for back office or network closet applications where space is limited
- 2U slide-out mounting brackets located at the top of the unit provide space for separate patch panels and allow for easy cable access

SEE NEXT PAGE FOR DETAILED UNIT MEASUREMENTS



1111 W. 35th Street
Chicago, IL 60609 USA
773.869.1234
www.tripplite.com

Specifications

Model	SRWF2U36
Rack Spaces	2U
Equipment Mounting Depth	Up to 36 in. / 914 mm
Load Rating*	150 lb. / 68 kg
Unit Dimensions (H x W x D)	43.24 x 23.31 x 4.48 in. / 1098 x 643 x 114 mm
Shipping Dimensions (H x W x D)	48.03 x 31.1 x 9.44 in. / 1220 x 790 x 240 mm
Unit Weight	58.86 lb. / 27 kg
Shipping Weight	62.83 lb. / 28.5 kg
Standards	Tested to EIA-310-E, NOM, RoHS, PCI-DSS

* The load rating includes the combined weight of the unit and installed equipment. The unit must be mounted to a stable surface with user-supplied anchors capable of bearing the full load.



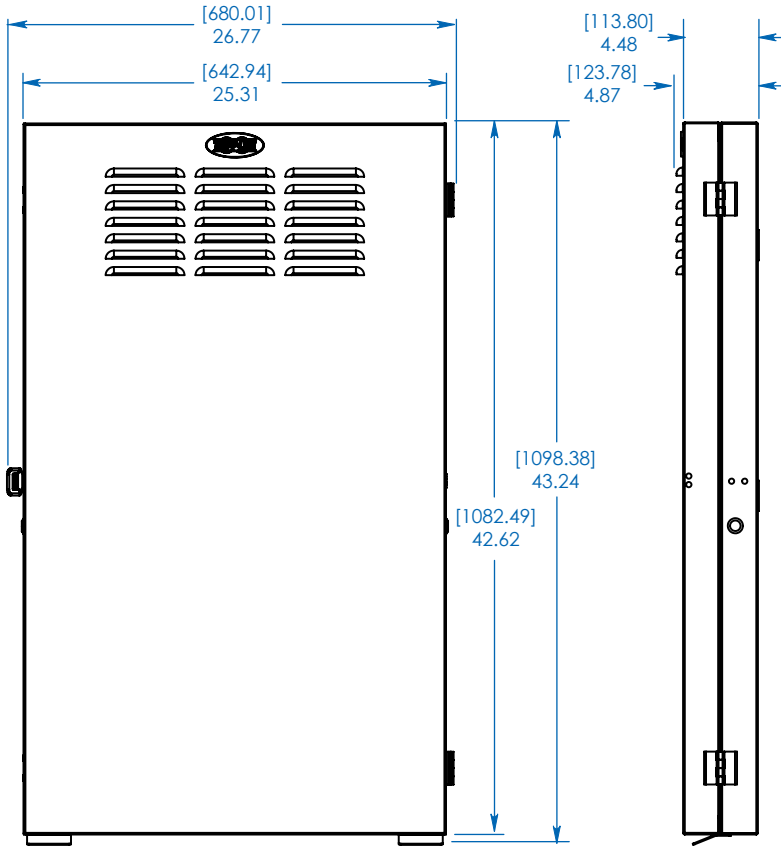

FRONT VIEW

SIDE VIEW

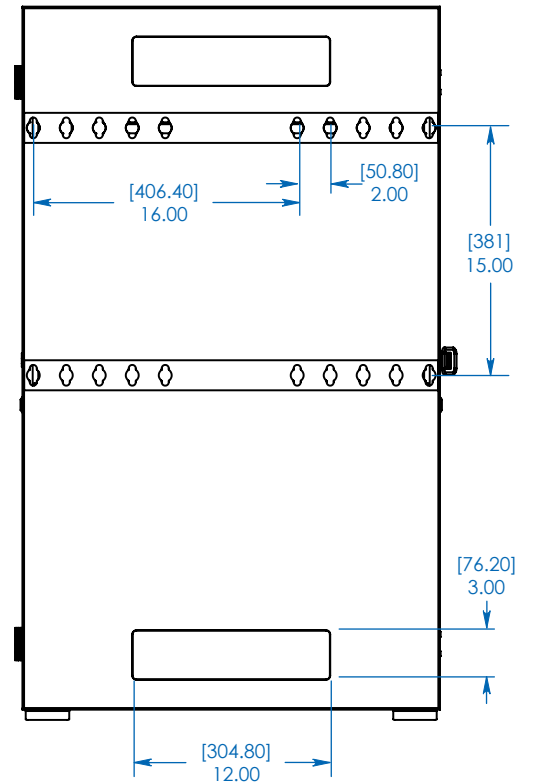

REAR VIEW

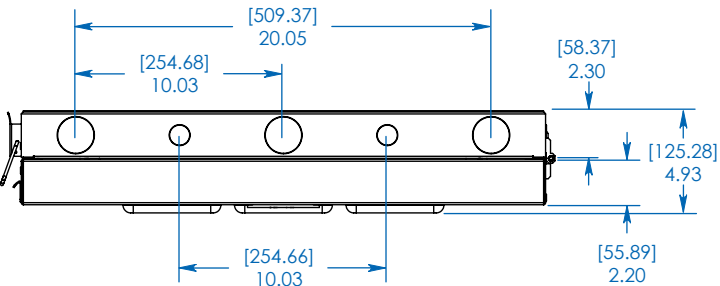

TOP VIEW

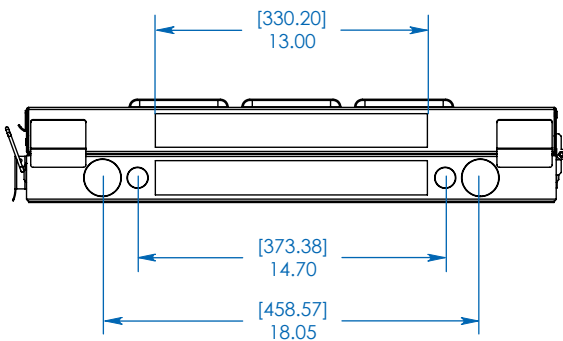

BOTTOM VIEW

Dimensions: [mm] INCHES

Tripp Lite has a policy of continuous improvement. Specifications are subject to change without notice.

MODEL:
SRWF2U36
TRIPP·LITE

1111 W. 35th Street
 Chicago, IL 60609 USA
 773.869.1234
 www.tripplite.com