



Chipsmall Limited consists of a professional team with an average of over 10 year of expertise in the distribution of electronic components. Based in Hongkong, we have already established firm and mutual-benefit business relationships with customers from,Europe,America and south Asia,supplying obsolete and hard-to-find components to meet their specific needs.

With the principle of "Quality Parts,Customers Priority,Honest Operation,and Considerate Service",our business mainly focus on the distribution of electronic components. Line cards we deal with include Microchip,ALPS,ROHM,Xilinx,Pulse,ON,Everlight and Freescale. Main products comprise IC,Modules,Potentiometer,IC Socket,Relay,Connector.Our parts cover such applications as commercial,industrial, and automotives areas.

We are looking forward to setting up business relationship with you and hope to provide you with the best service and solution. Let us make a better world for our industry!



Contact us

Tel: +86-755-8981 8866 Fax: +86-755-8427 6832

Email & Skype: info@chipsmall.com Web: www.chipsmall.com

Address: A1208, Overseas Decoration Building, #122 Zhenhua RD., Futian, Shenzhen, China



MODEL:

SRWF4U

SmartRack® Low-Profile Wall-Mount Rack Enclosure Cabinet



4 Rack Units



2U Patch Panel Bracket



150 lb. Load Rating



Sturdy Steel Construction



Locking Door and Top Panel



Standard 19" Rack Width



Convenient Cable Access



Adjustable Mounting Rails



Ventilated for Ample Airflow



Reversible Door

- A** Front Door (Lockable/Reversible)
- B** Top Panel Door (Lockable)
- C** 4U Vertical Mounting Brackets (Adjustable/Reversible)
- D** 2U Slide-Out Patch Panel Mounting Brackets
- E** Cable Access Holes
- F** Vents
- G** Wall-Mounting Slots
- H** Keys

Also Includes: Owner's manual and rack-mount equipment mounting hardware (12 M6 screws, 12 M6 nut washers and 12 12-24 screws).

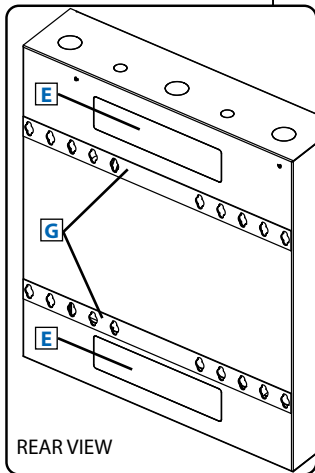
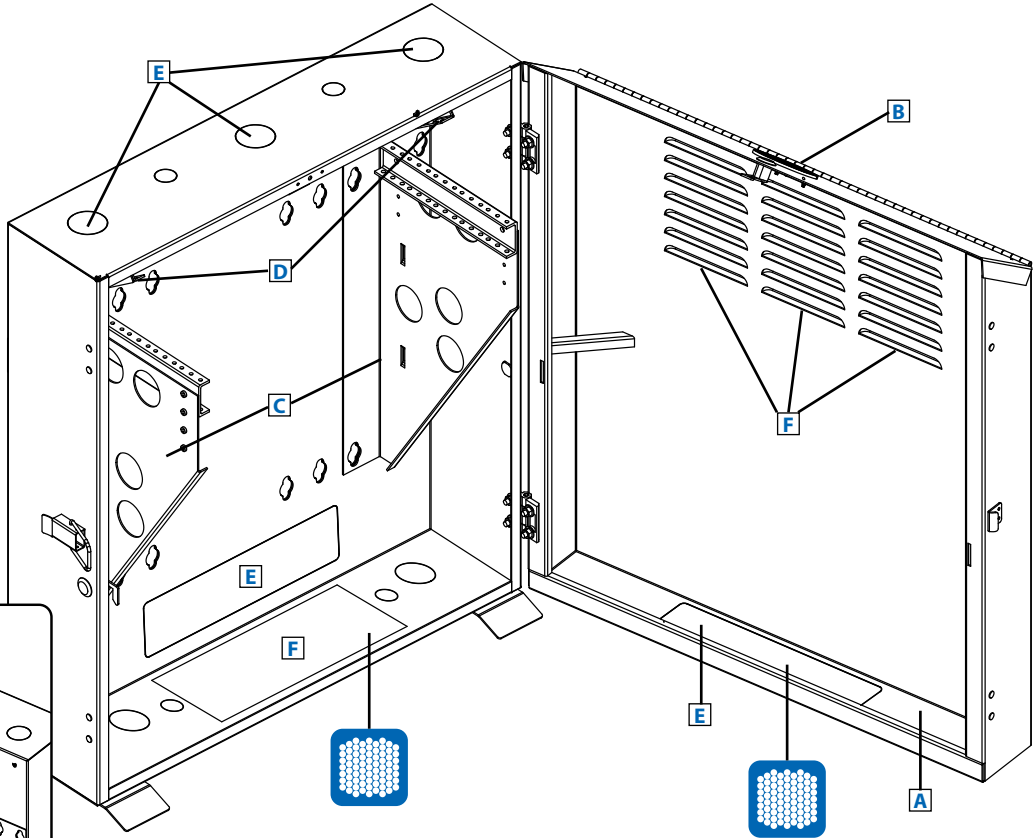

REAR VIEW

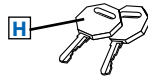

- Wall-mount enclosures provide convenient, locking storage for rack-mount IT devices and other equipment that should be off the floor, out of the way and secure
- Low-profile design with vertical equipment mounting is ideal for back office or network closet applications where space is limited



Specifications

Model	SRWF4U
Rack Spaces	4U
Equipment Mounting Depth	Up to 20 in. / 508 mm
Load Rating*	150 lb. / 68 kg
Unit Dimensions (H x W x D)	28.8 x 25.6 x 8.4 in. / 732 x 650 x 215 mm
Shipping Dimensions (H x W x D)	34.25 x 31.1 x 13.38 in. / 870 x 790 x 340 mm
Unit Weight	60.18 lb. / 27 kg
Shipping Weight	66.13 lb. / 30 kg
Standards	Tested to EIA-310-E, NOM, RoHS, PCI-DSS

* The load rating includes the combined weight of the unit and installed equipment. The unit must be mounted to a stable surface with user-supplied anchors capable of bearing the full load.

SEE NEXT PAGE FOR DETAILED UNIT MEASUREMENTS



1111 W. 35th Street
Chicago, IL 60609 USA
773.869.1234
www.tripplite.com

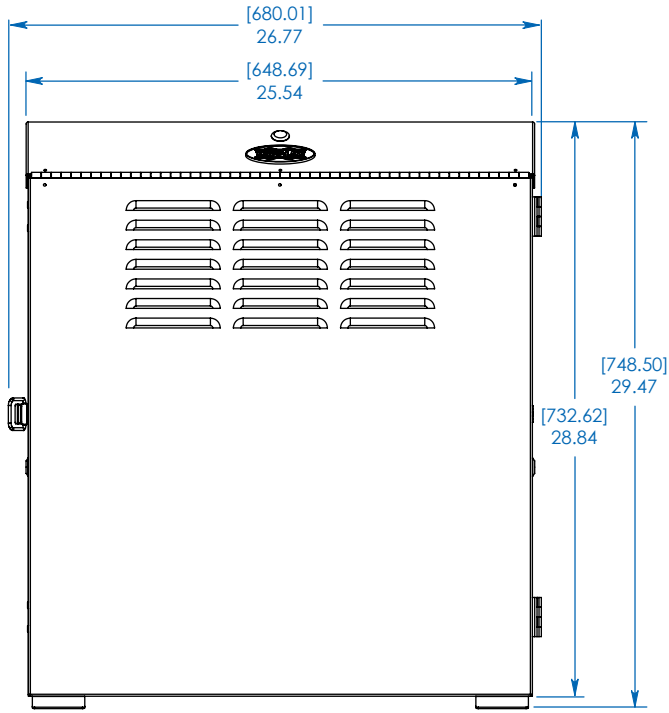

FRONT VIEW

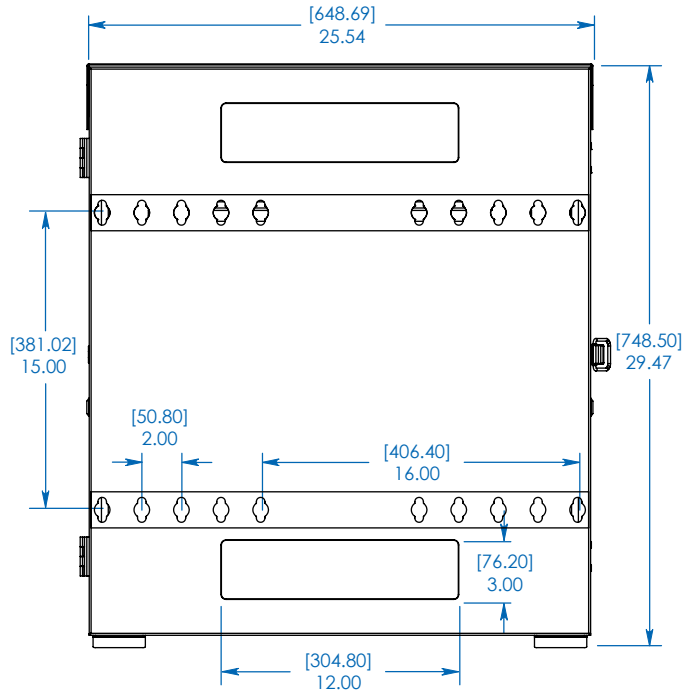

REAR VIEW

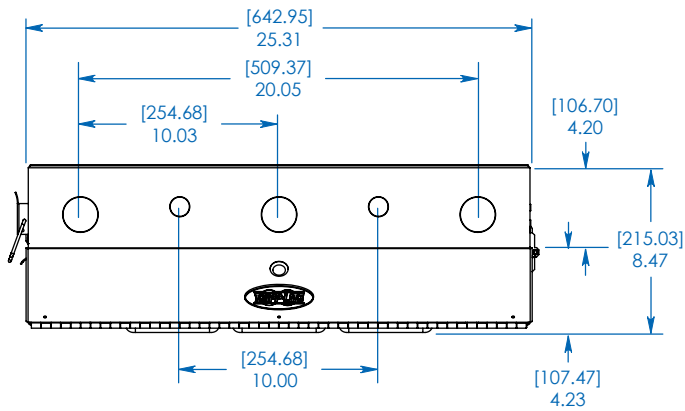

TOP VIEW

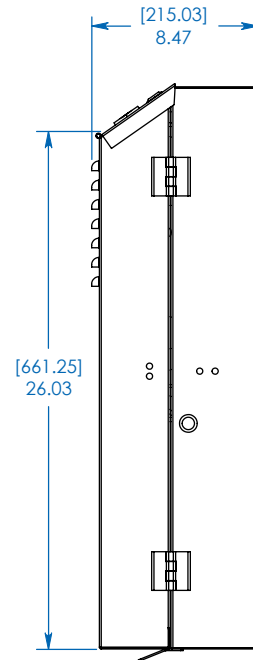

SIDE VIEW

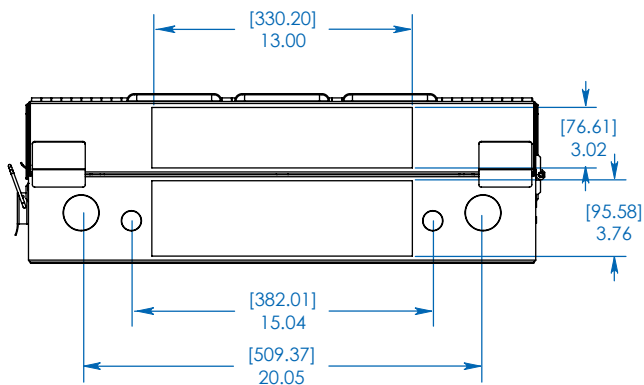

BOTTOM VIEW

MODEL:
SRWF4U
TRIPP-LITE

1111 W. 35th Street
 Chicago, IL 60609 USA
 773.869.1234
 www.tripplite.com

Dimensions: [mm] INCHES

Tripp Lite has a policy of continuous improvement. Specifications are subject to change without notice.