



Chipsmall Limited consists of a professional team with an average of over 10 year of expertise in the distribution of electronic components. Based in Hongkong, we have already established firm and mutual-benefit business relationships with customers from,Europe,America and south Asia,supplying obsolete and hard-to-find components to meet their specific needs.

With the principle of "Quality Parts,Customers Priority,Honest Operation,and Considerate Service",our business mainly focus on the distribution of electronic components. Line cards we deal with include Microchip,ALPS,ROHM,Xilinx,Pulse,ON,Everlight and Freescale. Main products comprise IC,Modules,Potentiometer,IC Socket,Relay,Connector.Our parts cover such applications as commercial,industrial, and automotives areas.

We are looking forward to setting up business relationship with you and hope to provide you with the best service and solution. Let us make a better world for our industry!



## Contact us

Tel: +86-755-8981 8866 Fax: +86-755-8427 6832

Email & Skype: info@chipsmall.com Web: www.chipsmall.com

Address: A1208, Overseas Decoration Building, #122 Zhenhua RD., Futian, Shenzhen, China



MODEL:

# SRW012UHD

## 12U Heavy-Duty Wall-Mount Open Frame Rack



12 Rack Units



150 lb. Load Rating



Accommodates Standard  
19-inch Equipment



Sturdy Steel  
Construction

- A** Top/Bottom Panel Frames
- B** Vertical Mounting Rails (2)
- C** Reinforcement Straps (2)
- D** Threaded (#12-24) Mounting Holes

Also Includes: Owner's Manual, M5 button head cap screws (8), 3 mm Hex Key and rackmount equipment mounting hardware (24 #12-24 screws).

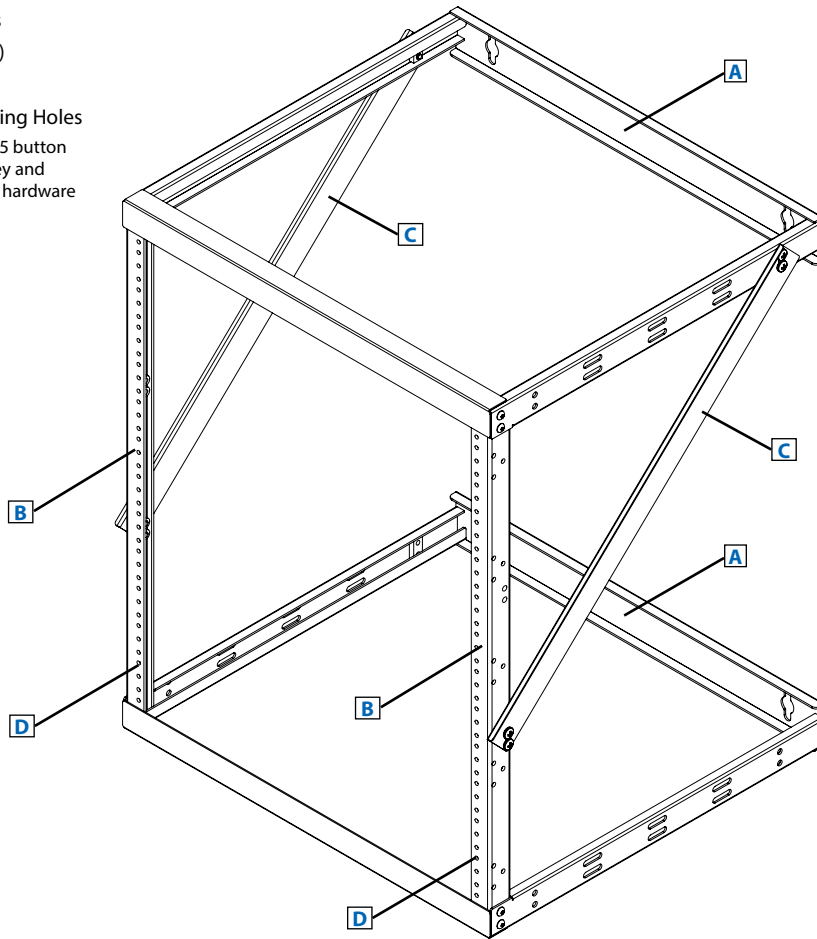

- Wall-mount racks provide convenient storage for rackmount IT devices and other equipment that should be off the floor and out of the way

- 2-post open-frame design is ideal for IT environments that do not require a lockable enclosure cabinet
- Ships disassembled for easy transport and assembly in tight spaces
- Threaded (#12-24) mounting holes enable fast equipment mounting
- Ideal for cost-conscious 19-inch rackmount applications



### Specifications

Model	SRW012UHD
Rack Spaces	12U
Equipment Mounting Depth	18 in. (45.72 cm)
Load Rating*	150 lb. (68 kg)
Unit Dimensions (H x W x D)	24.8 x 20.1 x 18.24 in. (63 x 51 x 46.3 cm)
Shipping Dimensions (H x W x D)	4 x 22 x 23.8 in. (10.16 x 55.88 x 60.45 cm)
Unit Weight	14.3 lb. (6.48 kg)
Shipping Weight	15.4 lb. (6.98 kg)
Standards	Meets EIA-310-D, IEC 60297-3-100, DIN 41494, NOM (Mexico) and RoHS standards

\* The load rating includes the combined weight of the unit and installed equipment. The unit must be mounted to a stable surface with user-supplied anchors capable of bearing the full load.  
Tripp Lite has a policy of continuous improvement. Specifications are subject to change without notice.

**SEE NEXT PAGE FOR DETAILED UNIT MEASUREMENTS**



1111 W. 35th Street  
Chicago, IL 60609 USA  
773.869.1234  
www.tripplite.com

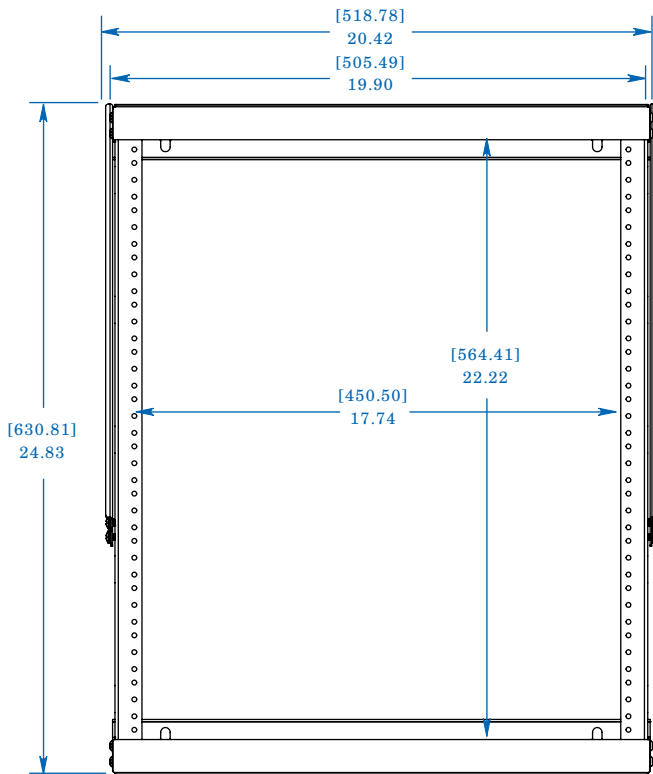

FRONT VIEW

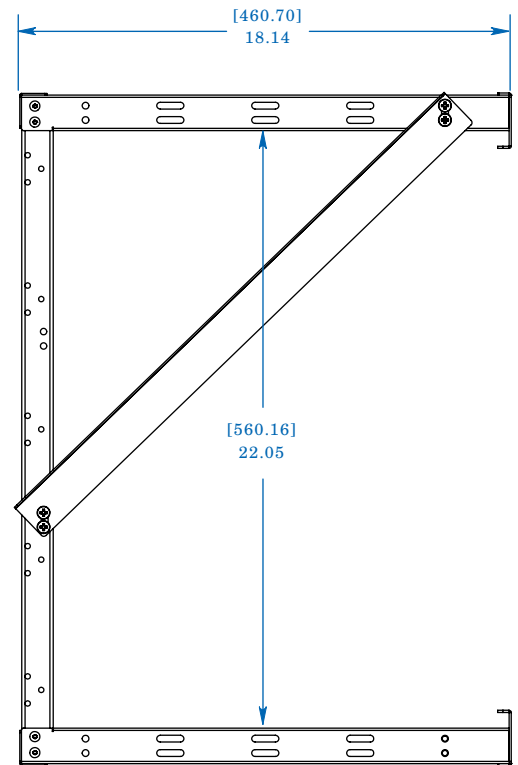

SIDE VIEW

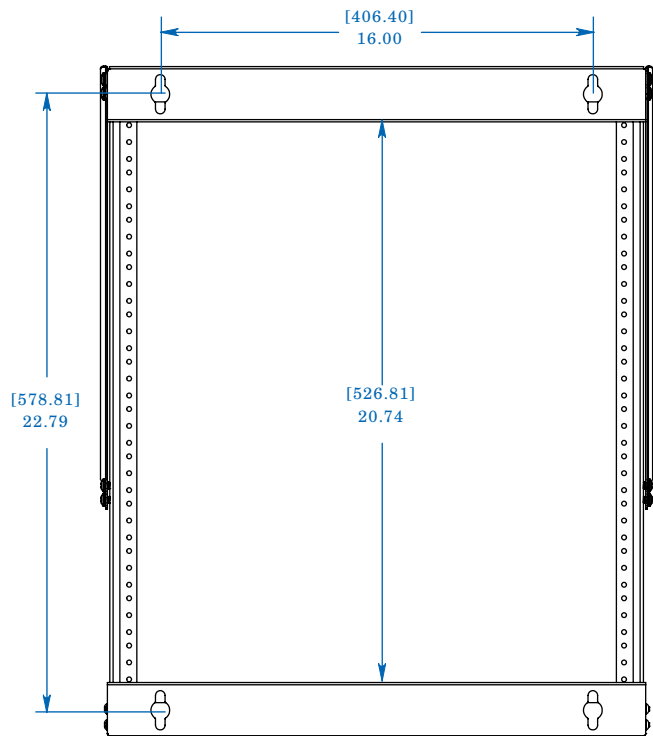

REAR VIEW

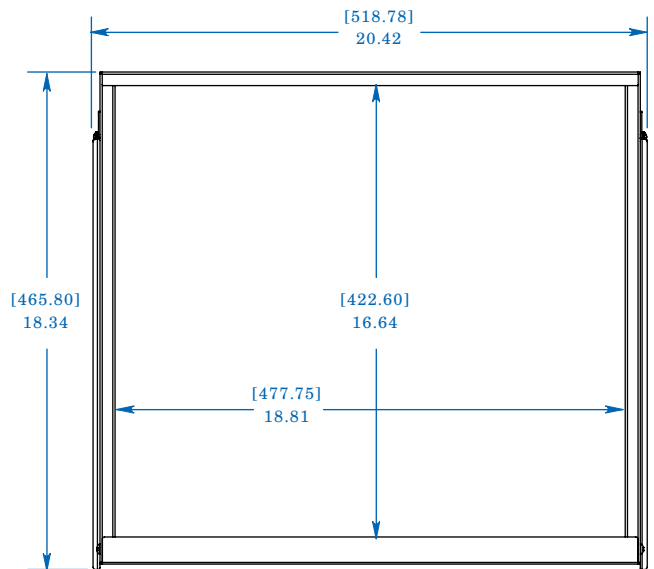

TOP VIEW

Dimensions: [mm] INCHES

Tripp Lite has a policy of continuous improvement. Specifications are subject to change without notice.

MODEL:  
**SRWO12UHD**  
**TRIPP·LITE**

1111 W. 35th Street  
 Chicago, IL 60609 USA  
 773.869.1234  
 www.triplite.com