



Chipsmall Limited consists of a professional team with an average of over 10 year of expertise in the distribution of electronic components. Based in Hongkong, we have already established firm and mutual-benefit business relationships with customers from,Europe,America and south Asia,supplying obsolete and hard-to-find components to meet their specific needs.

With the principle of “Quality Parts,Customers Priority,Honest Operation,and Considerate Service”,our business mainly focus on the distribution of electronic components. Line cards we deal with include Microchip,ALPS,ROHM,Xilinx,Pulse,ON,Everlight and Freescale. Main products comprise IC,Modules,Potentiometer,IC Socket,Relay,Connector.Our parts cover such applications as commercial,industrial, and automotives areas.

We are looking forward to setting up business relationship with you and hope to provide you with the best service and solution. Let us make a better world for our industry!



Contact us

Tel: +86-755-8981 8866 Fax: +86-755-8427 6832

Email & Skype: info@chipsmall.com Web: www.chipsmall.com

Address: A1208, Overseas Decoration Building, #122 Zhenhua RD., Futian, Shenzhen, China



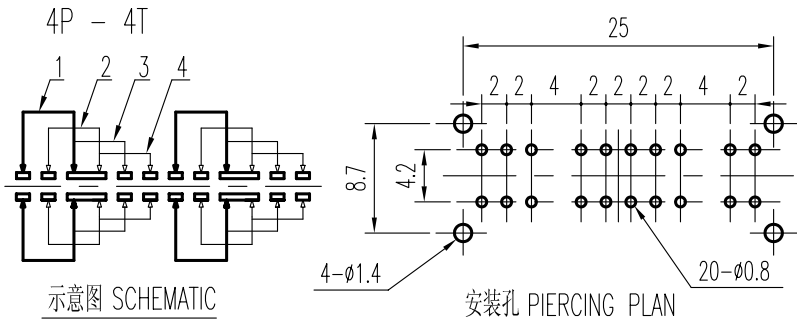
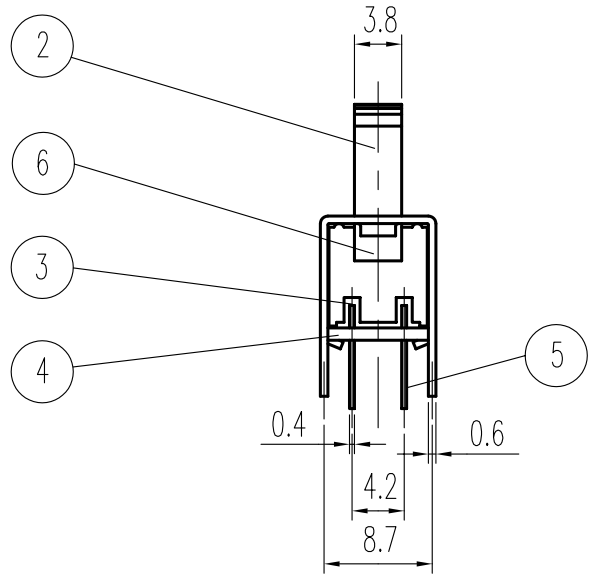
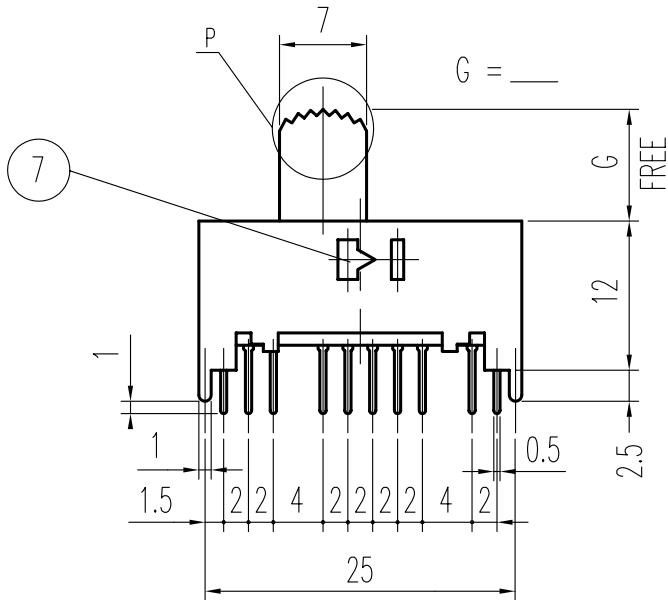
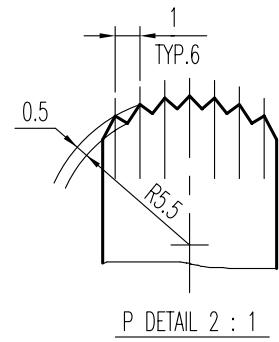
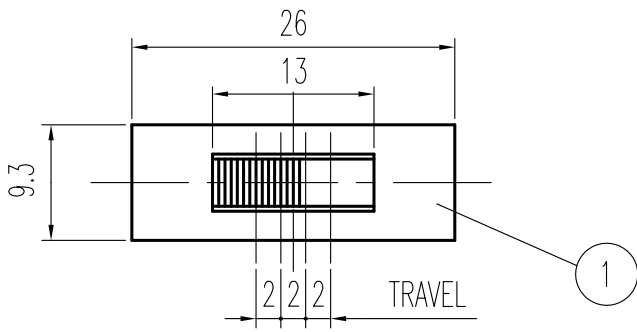

① 规格 Specifications

额定负荷 Ratings	DC 30_V 0.3_A
初期接触电阻 Initial Contact Resistance	30_mΩ Max.
绝缘电阻 Insulation Resistance	DC500_V 60_Sec. 100_MΩ Min.
抗电强度 Dielectric Voltage	AC 500_V (50~60HZ) 60_Sec.
操作力 Operating Force (gf)	A-B B-C C-D D-C C-B B-A 200±100 300±150 400±150
负荷寿命 Operating Life With Load	10,000 次 Cycles

7	钢珠	STEEL BALL	STEEL	2	NATURAL
6	弹簧	SPRING	STEEL	1	NATURAL
5	端子	TERMINAL	C2680R①	20	Ag PLATED
4	基板	TERMINAL BASE	PHENOL RESIN	1	YELLOW
3	接触片	CONTACT	C5210R①	4	Ag CLAD
2	胶柄	KNOB	P O M	1	G 4 - 15
1	铁壳	FRAME	S P C C	1	Ni PLATED
序号 NO.	零件 PART	材料 MATERIAL	数量 QTY	备注 REMARKS	

A01	ADD: 规格 Specifications 见 ①	王光云	06-06-14
	C2680R-EH → C2680R 见 ①		
	C5210R-EH/Ag CLAD → C5210R 见 ①		
01		赖立辉	11 JUL 98
标号 REV	内容 DESCRIPTION	签名 SIGN.	日期 DATE

TOLERANCES UNLESS OTHERWISE SPEC.		TITLE	SLIDE SWITCH		ITEM NO	SS-44D04-G	
UNDER 1	± 0.10	DRAWN	王光云	06-06-14	VERSION	A01	PAGE 1 OF 1
1 - 10	± 0.30	REVIEWED	张念明	06-06-14	SCALE		UNIT mm
OVER 10	± 0.50	APPROVED	高洪	06-06-15	PROJECTION		

COMAX ELECTRONICS (HUIZHOU) CO.,LTD.