



Chipsmall Limited consists of a professional team with an average of over 10 year of expertise in the distribution of electronic components. Based in Hongkong, we have already established firm and mutual-benefit business relationships with customers from,Europe,America and south Asia,supplying obsolete and hard-to-find components to meet their specific needs.

With the principle of “Quality Parts,Customers Priority,Honest Operation,and Considerate Service”,our business mainly focus on the distribution of electronic components. Line cards we deal with include Microchip,ALPS,ROHM,Xilinx,Pulse,ON,Everlight and Freescale. Main products comprise IC,Modules,Potentiometer,IC Socket,Relay,Connector.Our parts cover such applications as commercial,industrial, and automotives areas.

We are looking forward to setting up business relationship with you and hope to provide you with the best service and solution. Let us make a better world for our industry!



Contact us

Tel: +86-755-8981 8866 Fax: +86-755-8427 6832

Email & Skype: info@chipsmall.com Web: www.chipsmall.com

Address: A1208, Overseas Decoration Building, #122 Zhenhua RD., Futian, Shenzhen, China



DATE	REV	ECN	APP'D. BY
8/29/2017	A0	-	DHG
10/16/2017	A1	11125	GWL

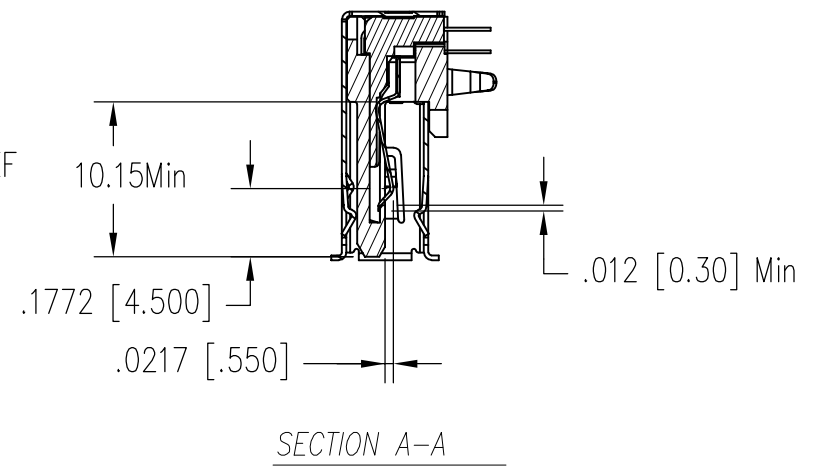
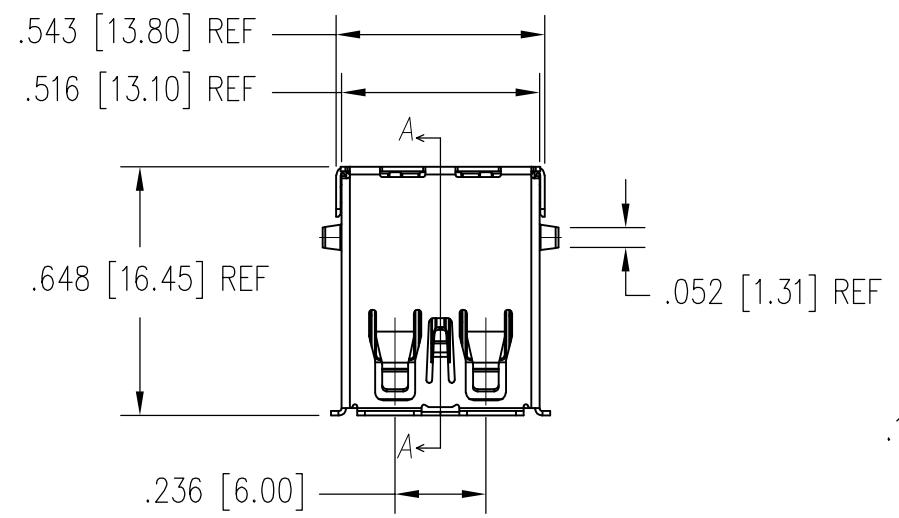

- NOTE:
- Material
 - Hsg: High Temperature Plastic; UL94V-0; Color: Blue.
 - Back Cover: High Temperature Plastic; UL94V-0; Color: Blue.
 - Contact:
 - 5 pin contact: Copper Alloy
 - 4 pin contact: Copper Alloy,
 - Shell: Copper Alloy
 - Finish:
 - Contact: Nickel Plated; Au Plating On Contact Area See Chart for Part Number; TIN On Solder Tail.
 - Shell: Nickel Plating.
 - For Product specifications See PR44-01

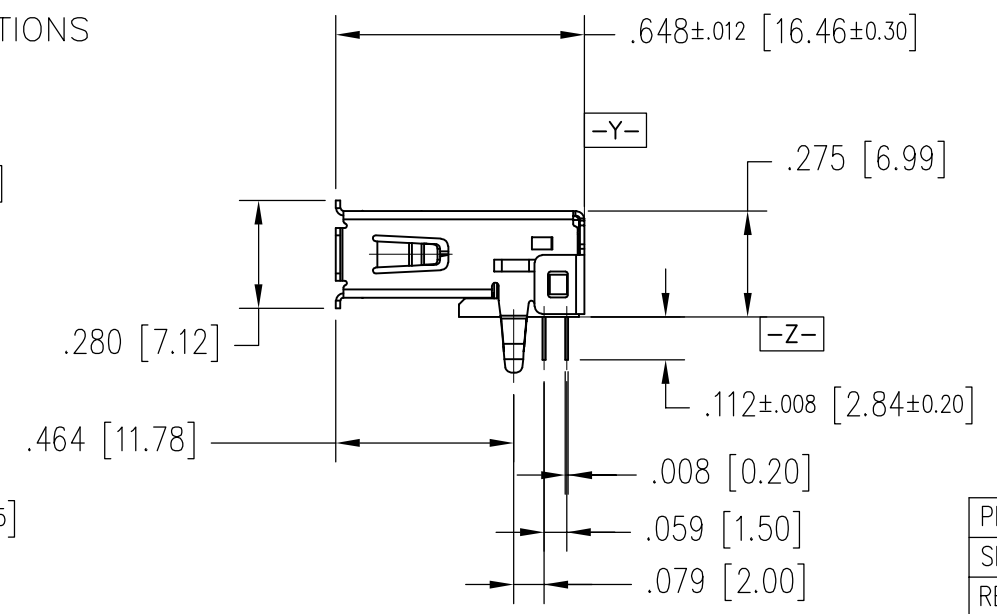
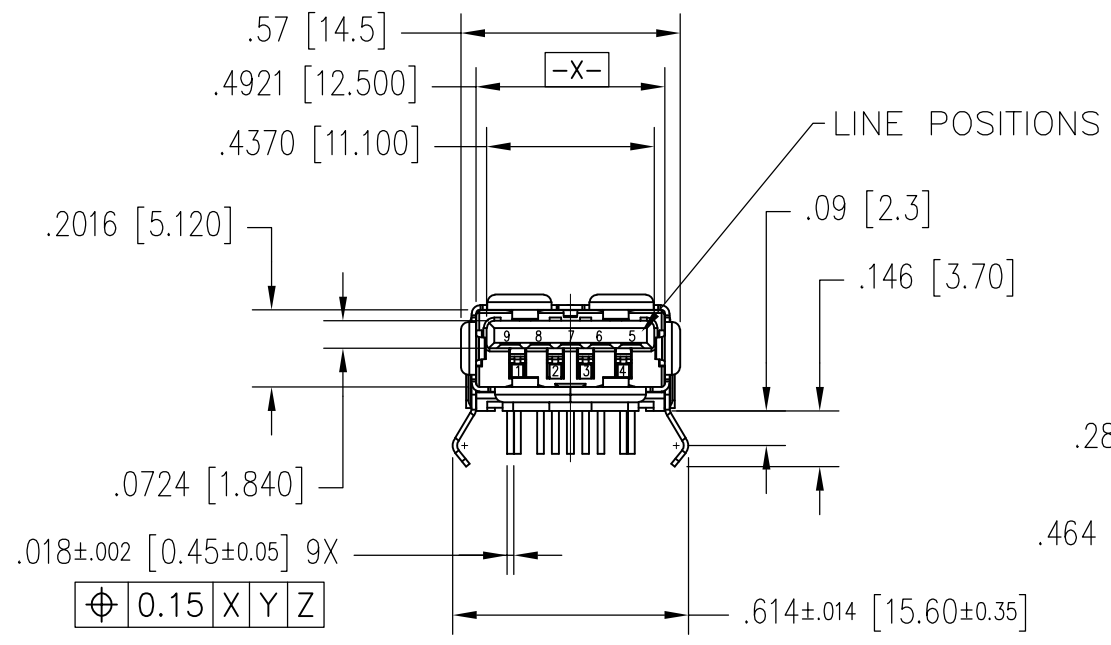

PIN NO.	1	2	3	4	5	6	7	8	9
SIGNAL NAME	VBUS	D-	D+	GND	SSRX-	SSRX+	GND_DRAIN	SSTX-	SSTX+
REMARK	USB2 Contact Pin					USB3 Contact Pin			

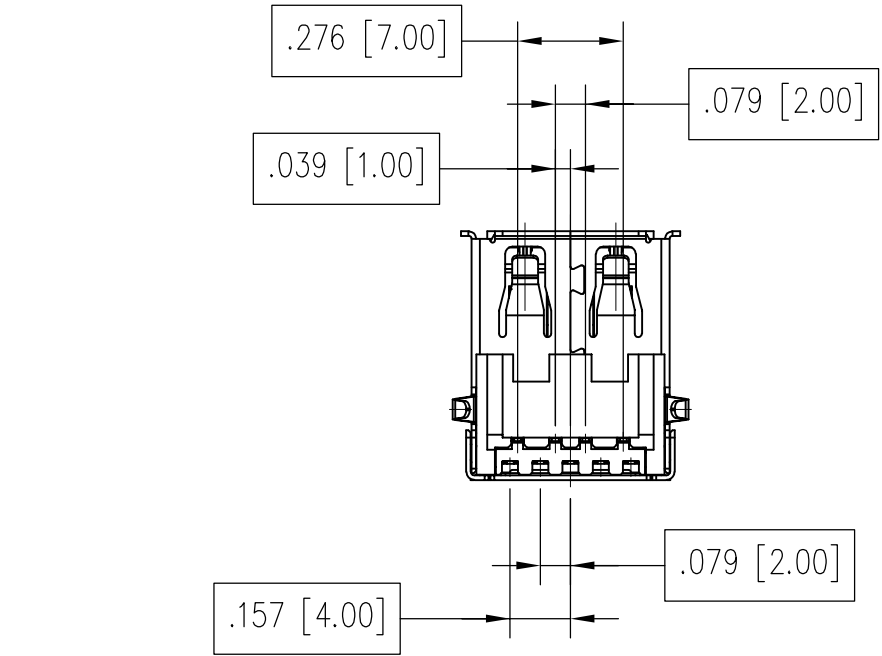

30 MICRO-INCHES [0.76um]	SS-52000-001
CONTACT PLATING IN MATING AREA	PART NUMBER

THIRD ANGLE PROJECTION

DRAWING IS SUBJECT TO CHANGE WITHOUT NOTICE

UNLESS OTHERWISE SPECIFIED DIMENSIONS INCHES [METRIC] TOLERANCES ARE:

ANGLES ± 1°

.XX [.X] ±.010" [±0.25]

.XXX [.XX] ±.008" [±0.20]

.XXXX [.XXX] ±.004" [±0.10]

DO NOT SCALE DRAWING

SHEET NO. 1 OF 2



1118 Susquehanna Trail South
Glen Rock, PA 17327-9199
(717) 235-7512
<http://www.stewartconnector.com>

TITLE: USB 3.0 Right Angle Receptacle Type A

THIS DRAWING AND THE SUBJECT MATTER SHOWN THEREON ARE CONFIDENTIAL AND THE PROPRIETARY PROPERTY OF STEWART CONNECTOR AND SHALL NOT BE REPRODUCED, COPIED, OR USED IN ANY MANNER WITHOUT PRIOR WRITTEN CONSENT OF STEWART CONNECTOR. ONE OR MORE U.S. PATENTS MAY APPLY TO THIS PRODUCT. FOR DETAILS, PLEASE VISIT: [HTTP://BELFUSE.COM/STEWART/STEWART_PATENTS/](http://BELFUSE.COM/STEWART/STEWART_PATENTS/)

DRN BY:	GWL	DATE	8/28/2017
APPD BY:	DHG	DATE	8/29/2017
DWG NO.	CT520001	REV.	A1

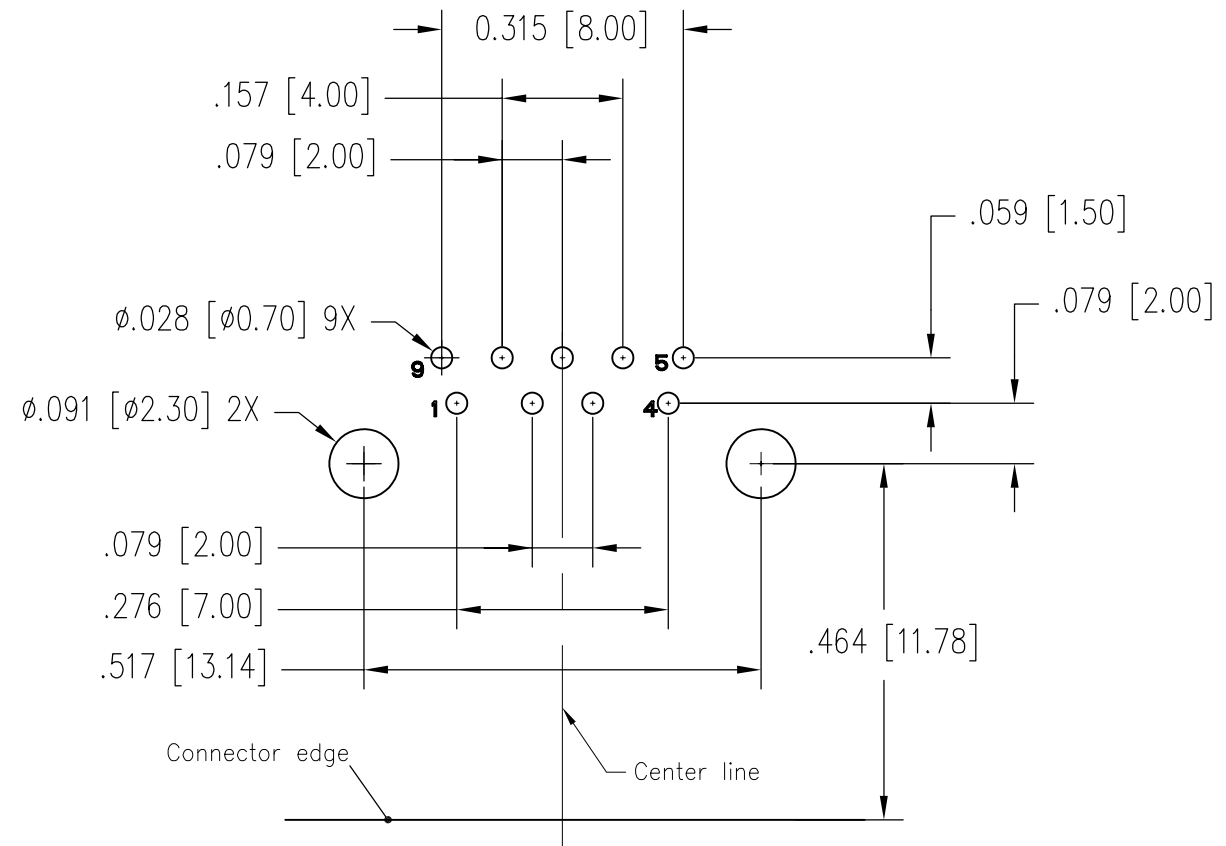

RECOMMENDED PCB LAYOUT(TOP VIEW)
 ALL TOL IS ±.004 [0.10]



THIRD ANGLE PROJECTION	
DRAWING IS SUBJECT TO CHANGE WITHOUT NOTICE	
UNLESS OTHERWISE SPECIFIED DIMENSIONS INCHES [METRIC]	
TOLERANCES ARE:	
ANGLES	± 1°
.XX [.X]	±.010" [±0.25]
.XXX [.XX]	±.008" [±0.20]
.XXXX [.XXX]	±.004" [±0.10]
DO NOT SCALE DRAWING	
SHEET NO.	2 OF 2

		11118 Susquehanna Trail South Glen Rock, PA 17327-9199 (717) 235-7512 http://www.stewartconnector.com	
TITLE: USB 3.0 Right Angle Receptacle Type A		DRN BY: GWL	DATE 8/28/2017
THIS DRAWING AND THE SUBJECT MATTER SHOWN THEREON ARE CONFIDENTIAL AND THE PROPRIETARY PROPERTY OF STEWART CONNECTOR AND SHALL NOT BE REPRODUCED, COPIED, OR USED IN ANY MANNER WITHOUT PRIOR WRITTEN CONSENT OF STEWART CONNECTOR. ONE OR MORE U.S. PATENTS MAY APPLY TO THIS PRODUCT. FOR DETAILS, PLEASE VISIT: HTTP://BELFUSE.COM/STEWART/STEWART_PATENTS/		APPD BY: DHG	DATE 8/29/2017
		DWG NO. CT520001	REV. A1