



Chipsmall Limited consists of a professional team with an average of over 10 year of expertise in the distribution of electronic components. Based in Hongkong, we have already established firm and mutual-benefit business relationships with customers from,Europe,America and south Asia,supplying obsolete and hard-to-find components to meet their specific needs.

With the principle of “Quality Parts,Customers Priority,Honest Operation,and Considerate Service”,our business mainly focus on the distribution of electronic components. Line cards we deal with include Microchip,ALPS,ROHM,Xilinx,Pulse,ON,Everlight and Freescale. Main products comprise IC,Modules,Potentiometer,IC Socket,Relay,Connector.Our parts cover such applications as commercial,industrial, and automotives areas.

We are looking forward to setting up business relationship with you and hope to provide you with the best service and solution. Let us make a better world for our industry!



## Contact us

Tel: +86-755-8981 8866 Fax: +86-755-8427 6832

Email & Skype: info@chipsmall.com Web: www.chipsmall.com

Address: A1208, Overseas Decoration Building, #122 Zhenhua RD., Futian, Shenzhen, China



DATE	REV	ECN	APP'D. BY
1-19-16	X0	-	DHG
2-4-16	A0	10528	ADB

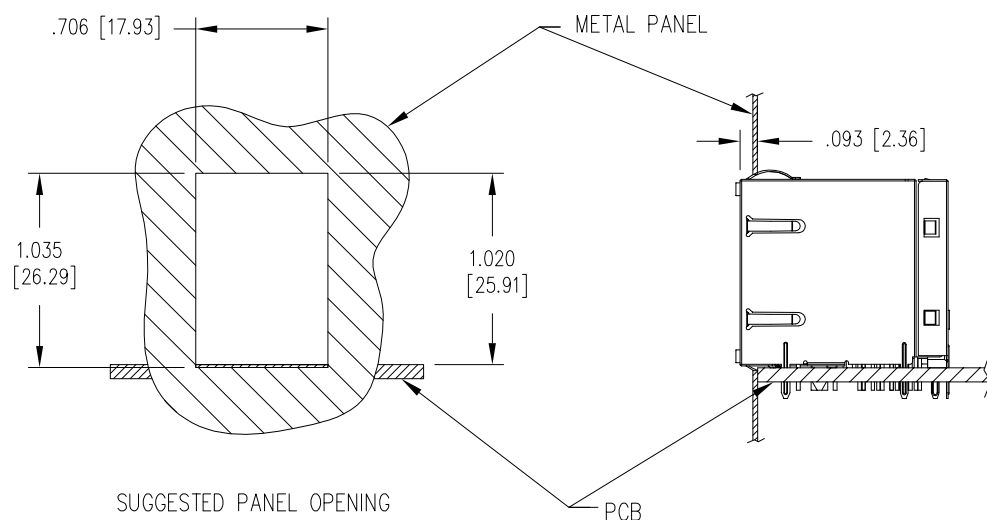
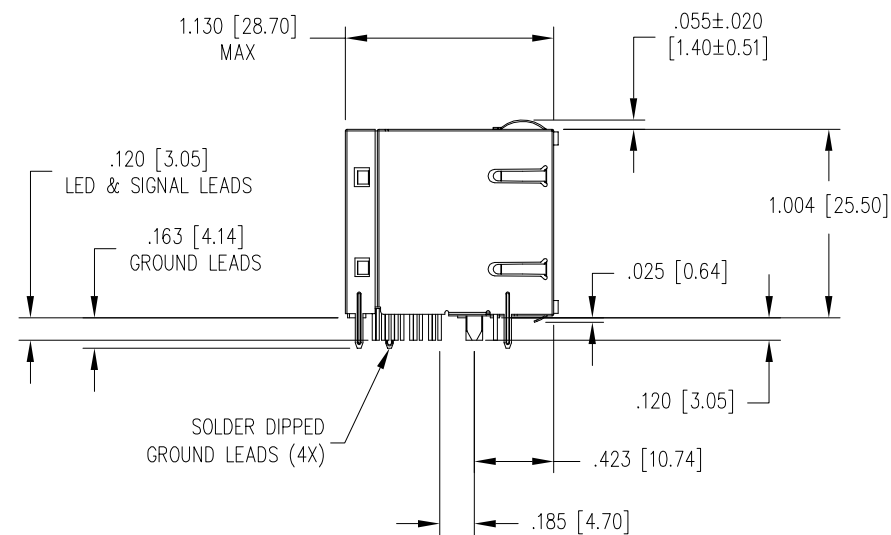
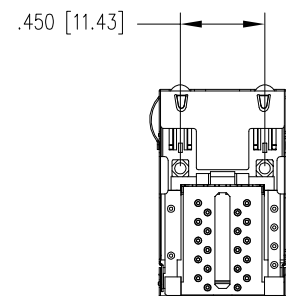
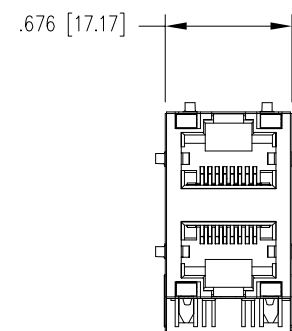
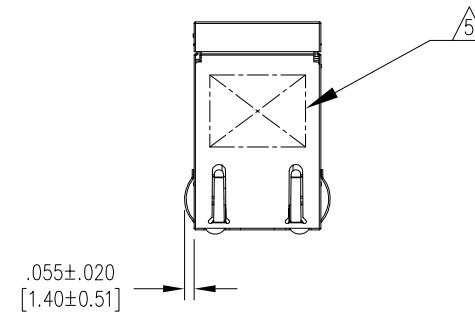

NOTES:

- CONNECTOR MATERIALS:  
HOUSING: THERMOPLASTIC UL94 V-0  
CONTACTS/SHIELD: COPPER ALLOY  
SHIELD PLATING: NICKEL OR "REFLOW" TIN  
CONTACT PLATING: SELECTIVE GOLD OR EQUIVALENT IN THE CONTACT AREA  
SEE CHART FOR PART NUMBER
  - FOR PRODUCT SPECIFICATIONS SEE PR022-01.
  - DIMENSIONS AND TOLERANCES COMPLY WITH TIA-1096 STANDARD.
  - THE SUGGESTED PANEL OPENING IS INTENDED TO GIVE USER THE ABILITY TO HAVE REASONABLE JACK/PANEL CLEARANCES, YET MAINTAIN GROUNDING CAPABILITY. THESE VARIABLES CAN BE ADJUSTED IN EITHER DIRECTION BUT MAY CARRY SOME CONSEQUENCES IN THE FORM OF LOWER MATING FORCES OR TIGHTER ASSEMBLY TOLERANCES.
- △ MARK PART WITH MFG LOGO, MFG NAME, PART NUMBER, AND DATE CODE.

50 MICRO-INCHES [1.27um]	SS-74500-029
CONTACT PLATING IN MATING AREA	PART NUMBER

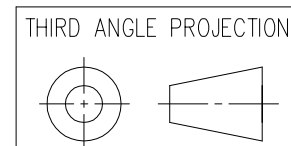

1118 Susquehanna Trail South  
Glen Rock, PA 17327-9199  
(717) 235-7512  
<http://www.stewartconnector.com>

DO NOT SCALE DRAWING  
DRAWING IS SUBJECT TO CHANGE WITHOUT NOTICE

DIMENSIONS: INCHES [METRIC]

UNLESS OTHERWISE SPECIFIED  
TOLERANCES ARE ±.010 [0.25]  
ANGLES ARE ± 1°

SHEET NO. 1 OF 3

**stewart**  
CONNECTOR  
a bel group

TITLE: 2X1 SHIELDED STACKJACK WITH YELLOW/GREEN UPPER AND LOWER LEADS

THIS DRAWING AND THE SUBJECT MATTER SHOWN THEREON ARE CONFIDENTIAL AND THE PROPRIETARY PROPERTY OF STEWART CONNECTOR AND SHALL NOT BE REPRODUCED, COPIED, OR USED IN ANY MANNER WITHOUT PRIOR WRITTEN CONSENT OF STEWART CONNECTOR. THIS PRODUCT MAY BE PROTECTED BY ONE OR MORE OF THE FOLLOWING US PATENTS: 5791942 6217391 6368159 6419526 6602097 687722 6964587 7048590 7086909 7568950 7686650 OTHER PATENTS MAY BE PENDING.

DRN BY: ADB	DATE 1-19-16
APPD BY: DHG	DATE 1-19-16
DWG NO. CT740227	REV. A0



LED INFORMATION

LED 2 & 4 POLARITY			LED 1 & 3 POLARITY		
PIN 9	PIN 10	COLOR	PIN 11	PIN 12	COLOR
+	-	YELLOW	+	-	GREEN

LED 1 & 3

VF (FORWARD VOLTAGE) IF=20mA GREEN 2.2V TYP.  
 λD (DOMINANT WAVELENGTH) IF=20mA GREEN 570nm TYP.

LED 2 & 4

VF (FORWARD VOLTAGE) IF=20mA YELLOW 2.1V TYP.  
 λD (DOMINANT WAVELENGTH) IF=20mA YELLOW 590nm TYP.

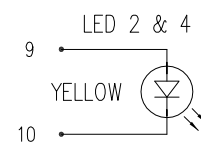

SCHMATIC

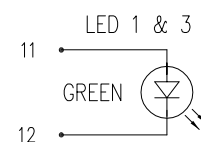
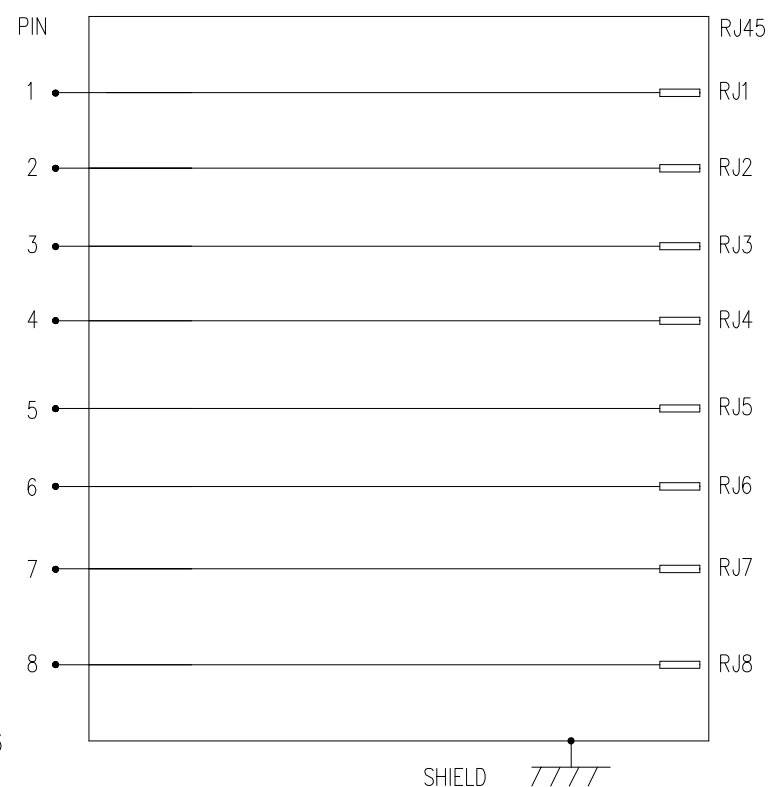

PORT ASSIGNMENT  
(FRONT VIEW OF JACK)

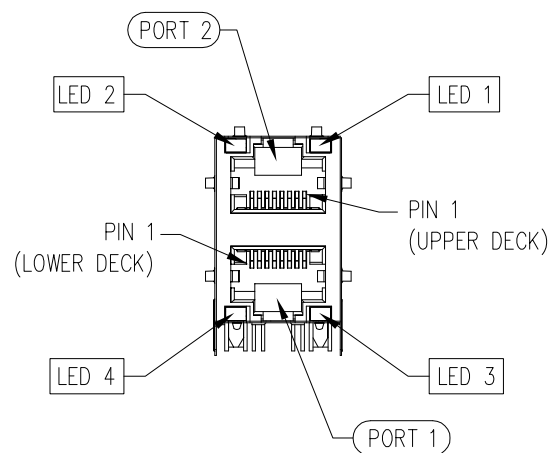

PORT ASSIGNMENT  
(PCB - COMPONENT SIDE VIEW)

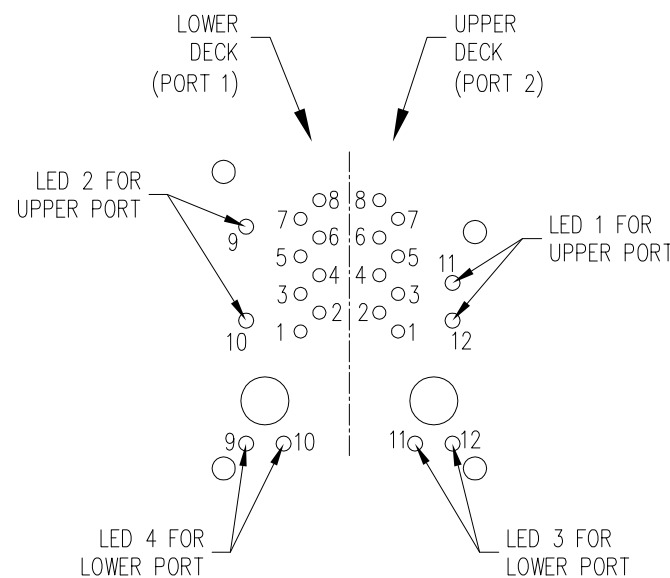
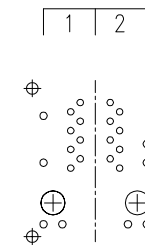

PIN-OUT INFORMATION  
(PCB - COMPONENT SIDE VIEW)

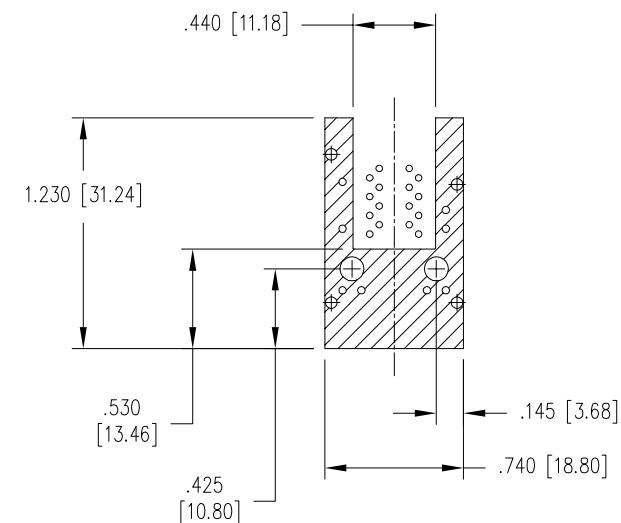

THE SHADED AREA ON THE CUSTOMER BOARD IS RECOMMENDED TO BE CLEAR OFF ANY VIA HOLE OR COMPONENT PAD.



THIRD ANGLE PROJECTION

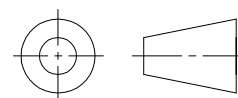

1118 Susquehanna Trail South  
 Glen Rock, PA 17327-9199  
 (717) 235-7512

<http://www.stewartconnector.com>

DO NOT SCALE DRAWING  
 DRAWING IS SUBJECT TO  
 CHANGE WITHOUT NOTICE

TITLE: 2X1 SHIELDED STACKJACK  
 WITH YELLOW/GREEN UPPER AND LOWER LEDS

DIMENSIONS: INCHES [METRIC]

THIS DRAWING AND THE SUBJECT MATTER SHOWN THEREON ARE CONFIDENTIAL AND THE PROPRIETARY PROPERTY OF STEWART CONNECTOR AND SHALL NOT BE REPRODUCED, COPIED, OR USED IN ANY MANNER WITHOUT PRIOR WRITTEN CONSENT OF STEWART CONNECTOR. THIS PRODUCT MAY BE PROTECTED BY ONE OR MORE OF THE FOLLOWING US PATENTS: 5791942 6217391 6368159 6419526 6602097 687722 6964587 7048590 7086909 7568950 7686650 OTHER PATENTS MAY BE PENDING.

DRN BY: ADB DATE 1-19-16

APPD BY: DHG DATE 1-19-16

SHEET NO. 2 OF 3

DWG NO. CT740227 REV. A0

B

A

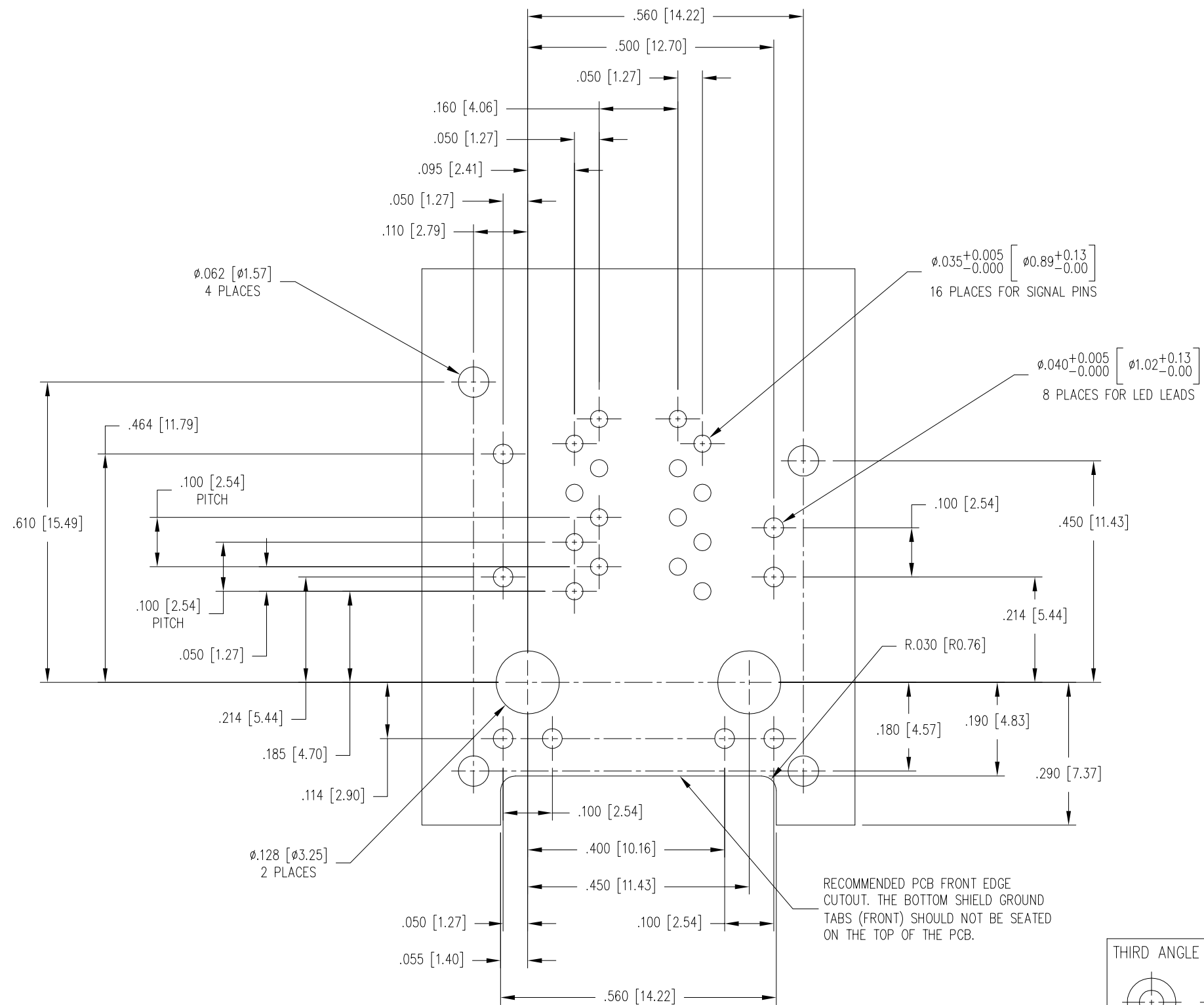

RECOMMENDED PCB FRONT EDGE CUTOUT. THE BOTTOM SHIELD GROUND TABS (FRONT) SHOULD NOT BE SEATED ON THE TOP OF THE PCB.

P.C.B. RECOMMENDED HOLE LAYOUT  
(COMPONENT SIDE VIEW - SCALE 4:1)

ALL CENTERLINE DIMENSIONS ARE BASIC.

ALL HOLE POSITIONS ARE  $\phi \pm 0.006$  [0.15]

RoHS



THIRD ANGLE PROJECTION

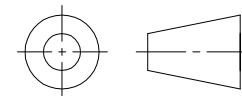

11118 Susquehanna Trail South  
Glen Rock, PA 17327-9199  
(717) 235-7512

<http://www.stewartconnector.com>

DO NOT SCALE DRAWING  
DRAWING IS SUBJECT TO  
CHANGE WITHOUT NOTICE

TITLE: 2X1 SHIELDED STACKJACK  
WITH YELLOW/GREEN UPPER AND LOWER LEADS

DIMENSIONS: INCHES [METRIC]

UNLESS OTHERWISE SPECIFIED  
TOLERANCES ARE  $\pm 0.010$  [0.25]  
ANGLES ARE  $\pm 1^\circ$

THIS DRAWING AND THE SUBJECT MATTER SHOWN THEREON ARE  
CONFIDENTIAL AND THE PROPRIETARY PROPERTY OF STEWART CONNECTOR  
AND SHALL NOT BE REPRODUCED, COPIED, OR USED IN ANY MANNER WITHOUT  
PRIOR WRITTEN CONSENT OF STEWART CONNECTOR. THIS PRODUCT  
MAY BE PROTECTED BY ONE OR MORE OF THE FOLLOWING US PATENTS:  
5791942 6217391 6368159 6419526 6602097 687722  
6964587 7048590 7086909 7568950 7686650  
OTHER PATENTS MAY BE PENDING.

DRN BY: ADB DATE 1-19-16

APPD BY: DHG DATE 1-19-16

DWG NO. CT740227 REV. A0

SHEET NO. 3 OF 3