



Chipsmall Limited consists of a professional team with an average of over 10 year of expertise in the distribution of electronic components. Based in Hongkong, we have already established firm and mutual-benefit business relationships with customers from,Europe,America and south Asia,supplying obsolete and hard-to-find components to meet their specific needs.

With the principle of “Quality Parts,Customers Priority,Honest Operation,and Considerate Service”,our business mainly focus on the distribution of electronic components. Line cards we deal with include Microchip,ALPS,ROHM,Xilinx,Pulse,ON,Everlight and Freescale. Main products comprise IC,Modules,Potentiometer,IC Socket,Relay,Connector.Our parts cover such applications as commercial,industrial, and automotives areas.

We are looking forward to setting up business relationship with you and hope to provide you with the best service and solution. Let us make a better world for our industry!



Contact us

Tel: +86-755-8981 8866 Fax: +86-755-8427 6832

Email & Skype: info@chipsmall.com Web: www.chipsmall.com

Address: A1208, Overseas Decoration Building, #122 Zhenhua RD., Futian, Shenzhen, China



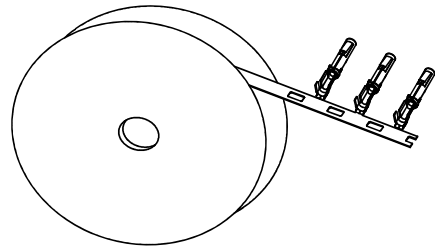

CONTACT ORIENTATION ON ROLL

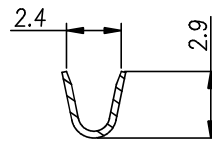

SECTION A-A

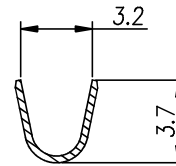

SECTION B-B

REVISIONS					
REV	ECO	DESCRIPTION	DATE	BY	APPR
B1	-	RELEASED DRAWING	JAN-18-2014	ARROW	TOMMY

NOTES : (UNLESS OTHERWISE SPECIFIED)

1. MATERIAL :
 - 1.1. CONTACT BODY : COPPER ALLOY.
 - 1.2. OUTER SPRING : STAINLESS STEEL.
2. SPECIFICATIONS :
 - 2.1 CURRENT RATING : 13A MAX.
 - 2.2 TERMINATION TYPE : CRIMPING.
 - 2.3 WIRE RANGE : 16~18AWG.
 - 2.4 WIRE INSULATION DIA(MAX) : Ø3.2mm.
3. ROHS COMPLIANT.
4. ALL DIMENSIONS ARE FOR REFERENCE USE ONLY.
5. AVAILABLE TOOLS :
 - 5.1 HAND CRIMPER : MFX-3954.
 - 5.2 CRIMP APPLICATOR : MFX-3957.
 - 5.3 EXTRACTION TOOL : QXRT16.

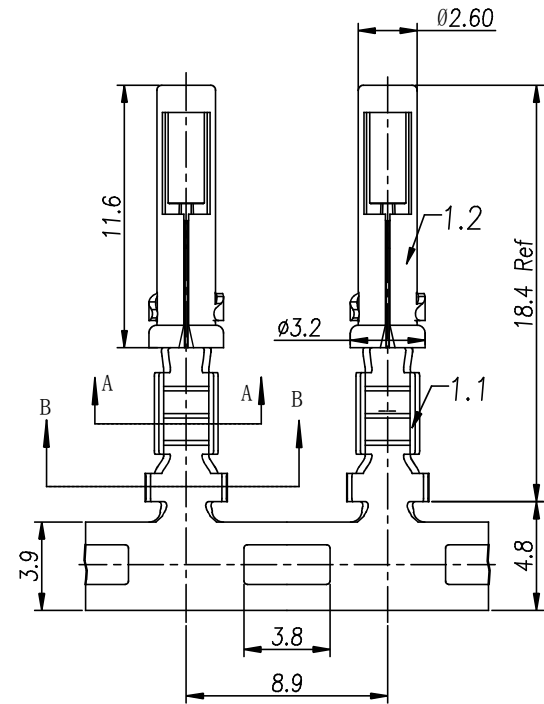

P/N	CONTACT PLATING(MATING AREA)
SS16M1T	TIN PLATING OVER NICKEL.
SS16M1F	GOLD FLASH PLATING OVER NICKEL.
SS16M1G10	10µ"GOLD PLATING OVER NICKEL.
SS16M1G15	15µ"GOLD PLATING OVER NICKEL.
SS16M1G30	30µ"GOLD PLATING OVER NICKEL.

QUANTITY	PART NUMBER	DESCRIPTION	ITEM
MATERIALS LIST			
UNLESS OTHERWISE SPECIFIED 1) All dimensions are in metric(mm). 2) Tolerances are as follows: 1 PL DEC ±0.30 Fractions ±1/64 2 PL DEC ±0.15 Angles ±1° 3 PL DEC ±0.08 3) Note reference =		SIGNATURES DRAWN: ARROW CHECKED: ENGINEER: APPROVAL:	DATE JAN-17-2014
MATERIAL SPECIFICATIONS: CUSTOMER:		 Sine Systems - www.amphenol-sine.com 44724 Morley Drive Clinton Township, MI 48036	
PROCESS SPECIFICATIONS: NEXT ASSY:		THIS DRAWING IS SUPPLIED FOR INFORMATION ONLY. DESIGN FEATURES, SPECIFICATIONS AND PERFORMANCE DATA SHOWN HEREON ARE THE PROPERTY OF THE AMPHENOL CORPORATION. NO RIGHTS OF REPRODUCTION ARE IMPLIED. ALL DIMENSIONS ARE SUBJECT TO NORMAL MANUFACTURING VARIATIONS.	ECO-MATE, SOCKET CONTACT, STAMPED, 16-18AWG, SIZE 16 SIZE: B C- SCALE: NONE DWG NO: SS16M1XX REVISION: B1 SHEET 1 OF 1

TITLE: ECO-MATE, SOCKET CONTACT, STAMPED, 16-18AWG, SIZE 16
 DWG NO.: SS16M1XX
 REV: B1
 SH: 1
 OF: 1