



Chipsmall Limited consists of a professional team with an average of over 10 year of expertise in the distribution of electronic components. Based in Hongkong, we have already established firm and mutual-benefit business relationships with customers from,Europe,America and south Asia,supplying obsolete and hard-to-find components to meet their specific needs.

With the principle of “Quality Parts,Customers Priority,Honest Operation,and Considerate Service”,our business mainly focus on the distribution of electronic components. Line cards we deal with include Microchip,ALPS,ROHM,Xilinx,Pulse,ON,Everlight and Freescale. Main products comprise IC,Modules,Potentiometer,IC Socket,Relay,Connector.Our parts cover such applications as commercial,industrial, and automotives areas.

We are looking forward to setting up business relationship with you and hope to provide you with the best service and solution. Let us make a better world for our industry!



Contact us

Tel: +86-755-8981 8866 Fax: +86-755-8427 6832

Email & Skype: info@chipsmall.com Web: www.chipsmall.com

Address: A1208, Overseas Decoration Building, #122 Zhenhua RD., Futian, Shenzhen, China



Critical Conduction Mode PFC Control IC SSC2005SC

General Description

SSC2005SC is a Critical Conduction Mode (CRM) control IC for power factor correction (PFC).

Since no input voltage sensing and no auxiliary winding for inductor current detection are required, the IC allows the realization of low standby power and the low number of external components. The product achieves high cost-performance and high efficiency PFC converter system.

Features and Benefits

- Inductor Current Detection
(No auxiliary winding required)
- Low Standby Power
(No input voltage sensing required)
- Minimum Off-time Limitation Function to restrict the Rise of Operation Frequency
- High Accuracy Overcurrent detection: $-0.60\text{ V} \pm 5\%$
- Protections
 - Overcurrent Protection (OCP): Pulse-by-pulse
 - Overshoot Protection (OVP): Auto restart
 - FB Pin Undervoltage Protection (FB_UVP): Auto restart
 - Thermal Shutdown Protection with hysteresis (TSD): Auto restart

Typical Application Circuit

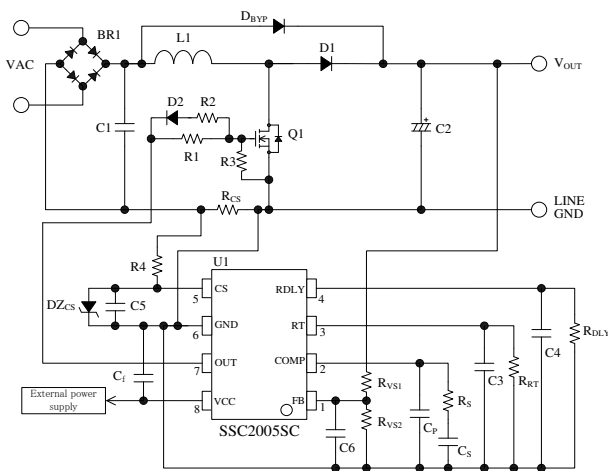

TC_SSC2005SC_1_R2

Package

SOIC8



Not to scale

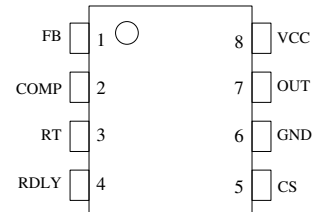

Electrical Characteristics

- VCC Pin Absolute Maximum Ratings, $V_{CC} = 28\text{ V}$
- OUT Pin Source Current, $I_{OUT(SRC)} = -500\text{ mA}$
- OUT Pin Sink Current, $I_{OUT(SNK)} = 1000\text{ mA}$

Applications

PFC circuit up to 200 W of output power such as:

- AC/DC power supply
- Digital appliances (large size LCD television and so forth).
- OA equipment (Computer, Server, Monitor, and so forth).
- Communication facilities

CONTENTS

| | |
|---|----|
| General Description | 1 |
| 1. Absolute Maximum Ratings | 3 |
| 2. Electrical Characteristics | 3 |
| 3. Functional Block Diagram | 5 |
| 4. Pin Configuration Definitions | 5 |
| 5. Typical Application Circuit | 6 |
| 6. Package Outline | 7 |
| 7. Marking Diagram | 7 |
| 8. Operational Description | 8 |
| 8.1 Critical Conduction Mode: CRM | 8 |
| 8.2 Startup Operation | 9 |
| 8.3 Restart Circuit | 9 |
| 8.4 Maximum On-time Setting | 9 |
| 8.5 Zero Current Detection and Bottom-on Timing (Delay Time) Setting | 10 |
| 8.6 Minimum Off-time Limit Function | 11 |
| 8.7 Overvoltage Protection (OVP) | 11 |
| 8.8 FB pin Under Voltage Protection (FB_UVP) | 11 |
| 8.9 Overcurrent Protection (OCP) | 12 |
| 9. Design Notes | 12 |
| 9.1 Inductor Setup | 12 |
| 9.2 External Components | 13 |
| 9.3 PCB Trace Layout and Component Placement | 15 |
| 10. Reference Design of Power Supply | 17 |
| OPERATING PRECAUTIONS | 18 |
| IMPORTANT NOTES | 19 |

1. Absolute Maximum Ratings

- For additional details, refer to the datasheet.
- The polarity value for current specifies a sink as “+”, and a source as “-”, referencing the IC.
- Unless specifically noted $T_A = 25\text{ }^\circ\text{C}$

| Parameter | Symbol | Conditions | Pins | Rating | Unit | Notes |
|-------------------------------|----------------|------------|-------|--------------|------------------|-------|
| VCC Pin Voltage | V_{CC} | | 8 – 6 | 28 | V | |
| OUT Pin Source Current | $I_{OUT(SRC)}$ | | 7 – 6 | - 500 | mA | |
| OUT Pin Sink Current | $I_{OUT(SNK)}$ | | 7 – 6 | 1000 | mA | |
| FB Pin Voltage | V_{FB} | | 1 – 6 | - 0.3 to 5 | V | |
| COMP Pin Current | I_{COMP} | | 2 – 6 | - 200 to 200 | μA | |
| RT Pin Current | I_{RT} | | 3 – 6 | - 500 to 0 | μA | |
| RDLY Pin Current | I_{RDLY} | | 4 – 6 | - 500 to 0 | μA | |
| CS Pin Voltage | V_{CS} | | 5 – 6 | - 5 to 0.3 | V | |
| Allowable Power Dissipation | P_D | | - | 0.5 | W | |
| Operating Ambient Temperature | T_{OP} | | - | - 40 to 110 | $^\circ\text{C}$ | |
| Storage Temperature | T_{stg} | | - | - 40 to 150 | $^\circ\text{C}$ | |
| Junction Temperature | T_j | | - | 150 | $^\circ\text{C}$ | |

2. Electrical Characteristics

- For additional details, refer to the datasheet.
- The polarity value for current specifies a sink as “+”, and a source as “-”, referencing the IC.
- Unless specifically noted, $T_A = 25\text{ }^\circ\text{C}$, $V_{CC} = 14\text{ V}$, $V_{CS} = 0.1\text{ V}$

| Parameter | Symbol | Conditions | Pins | Min. | Typ. | Max. | Unit |
|---------------------------------------|----------------|---|----------------|-------|-------|-------|---------------|
| Power Supply Operation | | | | | | | |
| Operation Start Voltage | $V_{CC(ON)}$ | | 8 – 6 | 10.5 | 12.0 | 13.5 | V |
| Operation Stop Voltage | $V_{CC(OFF)}$ | | 8 – 6 | 8.2 | 9.5 | 11.0 | V |
| Operation Voltage Hysteresis | $V_{CC(HYS)}$ | | 8 – 6 | 1.4 | 2.5 | 3.1 | V |
| Circuit Current in Operation | $I_{CC(ON)}$ | | 8 – 6 | 2.0 | 3.1 | 4.4 | mA |
| Circuit Current in Non-Operation | $I_{CC(OFF)}$ | $V_{CC} = 9.5\text{ V}$ | 8 – 6 | 40 | 80 | 160 | μA |
| Oscillation Operation | | | | | | | |
| Maximum On-Time | $t_{ON(MAX)}$ | $V_{FB} = 1.5\text{ V}$ $R_{RT} = 22\text{ k}\Omega$ | 7 – 6 | 15 | 23 | 33 | μs |
| Minimum Off-Time | $t_{OFF(MIN)}$ | $R_{DRY} = 22\text{ k}\Omega$ | 7 – 6 | 1.35 | 1.95 | 2.80 | μs |
| RDLY Pin Voltage | V_{RDLY} | | 4 – 6 | 1.3 | 1.5 | 1.7 | V |
| RT Pin Voltage | V_{RT} | | 3 – 6 | 1.3 | 1.5 | 1.7 | V |
| Feedback Control Voltage | V_{FB} | | 1 – 6 | 2.46 | 2.50 | 2.54 | V |
| Feedback Line Regulation | $V_{FB(LR)}$ | | 1 – 6 | - 8 | 1 | 12 | mV |
| FB Pin Bias Current | I_{FB} | | 1 – 6 | - 3.2 | - 2.0 | - 1.0 | μA |
| Error Amplifier Transconductance Gain | g_m | | 1 – 6 2 – 6 | 60 | 103 | 150 | μS |

| Parameter | Symbol | Conditions | Pins | Min. | Typ. | Max. | Unit |
|--|-----------------|--------------------------------|-------|-----------------------|-----------------------|-----------------------|----------------------|
| COMP Pin Sink Current | $I_{COMP(SNK)}$ | | 2 – 6 | 18 | 40 | 72 | μA |
| COMP Pin Source Current | $I_{COMP(SRC)}$ | | 2 – 6 | - 72 | - 40 | - 18 | μA |
| Zero Duty COMP Voltage | $V_{COMP(ZD)}$ | | 2 – 6 | 0.50 | 0.65 | 0.90 | V |
| Restart Time | t_{RS} | | - | 30 | 50 | 80 | μs |
| Drive Output | | | | | | | |
| Output Voltage (High) | V_{OH} | $I_{OUT} = -100 \text{ mA}$ | 7 – 6 | 10.0 | 12.0 | 13.5 | V |
| Output Voltage (low) | V_{OL} | $I_{OUT} = 200 \text{ mA}$ | 7 – 6 | 0.40 | 0.75 | 1.25 | V |
| Output Rise Time ⁽¹⁾ | t_r | $C_{OUT} = 1000 \text{ pF}$ | 7 – 6 | - | 60 | 120 | ns |
| Output Fall Time ⁽¹⁾ | t_f | $C_{OUT} = 1000 \text{ pF}$ | 7 – 6 | - | 20 | 70 | ns |
| Zero Current Detection and Overcurrent Protection | | | | | | | |
| Zero Current Detection Threshold Voltage | $V_{CS(ZCD)}$ | | 5 – 6 | - 20 | - 10 | 0 | mV |
| Zero Current Detection Delay Time ⁽²⁾ | $t_{DLY(ZCD)}$ | $R_{DLY} = 22 \text{ k}\Omega$ | 5 – 6 | 0.55 | 0.95 | 1.17 | μs |
| Overcurrent Protection Threshold Voltage | $V_{CS(OC)}$ | | 5 – 6 | - 0.63 | - 0.60 | - 0.57 | V |
| Overcurrent Protection Delay Time ⁽²⁾ | $t_{DLY(OC)}$ | | 5 – 6 | 100 | 250 | 400 | ns |
| CS Pin Source Current | I_{CS} | | 5 – 6 | - 110 | - 75 | - 40 | μA |
| FB Pin Protection | | | | | | | |
| Overvoltage Protection Threshold Voltage | V_{OVP} | | 1 – 6 | $1.075 \times V_{FB}$ | $1.090 \times V_{FB}$ | $1.105 \times V_{FB}$ | V |
| Overvoltage Protection Hysteresis | $V_{OVP(HYS)}$ | | 1 – 6 | 55 | 90 | 125 | mV |
| Undervoltage Protection Threshold Voltage | V_{UVP} | | 1 – 6 | 200 | 300 | 400 | mV |
| Undervoltage Protection Hysteresis | $V_{UVP(HYS)}$ | | 1 – 6 | 80 | 120 | 160 | mV |
| Thermal Shutdown | | | | | | | |
| Thermal Shutdown Threshold ⁽²⁾ | $T_{j(TSD)}$ | | - | 135 | 150 | - | $^{\circ}\text{C}$ |
| Thermal Shutdown Hysteresis ⁽²⁾ | $T_{j(TSDHYS)}$ | | - | - | 10 | - | $^{\circ}\text{C}$ |
| Thermal Resistance | | | | | | | |
| Junction to Ambient Resistance ⁽²⁾ | θ_{j-A} | | - | - | - | 180 | $^{\circ}\text{C/W}$ |

⁽¹⁾ Shown in Figure 3-1

⁽²⁾ Design assurance item

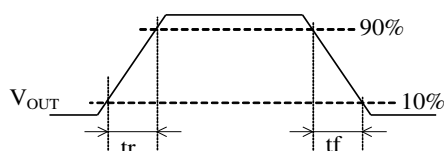
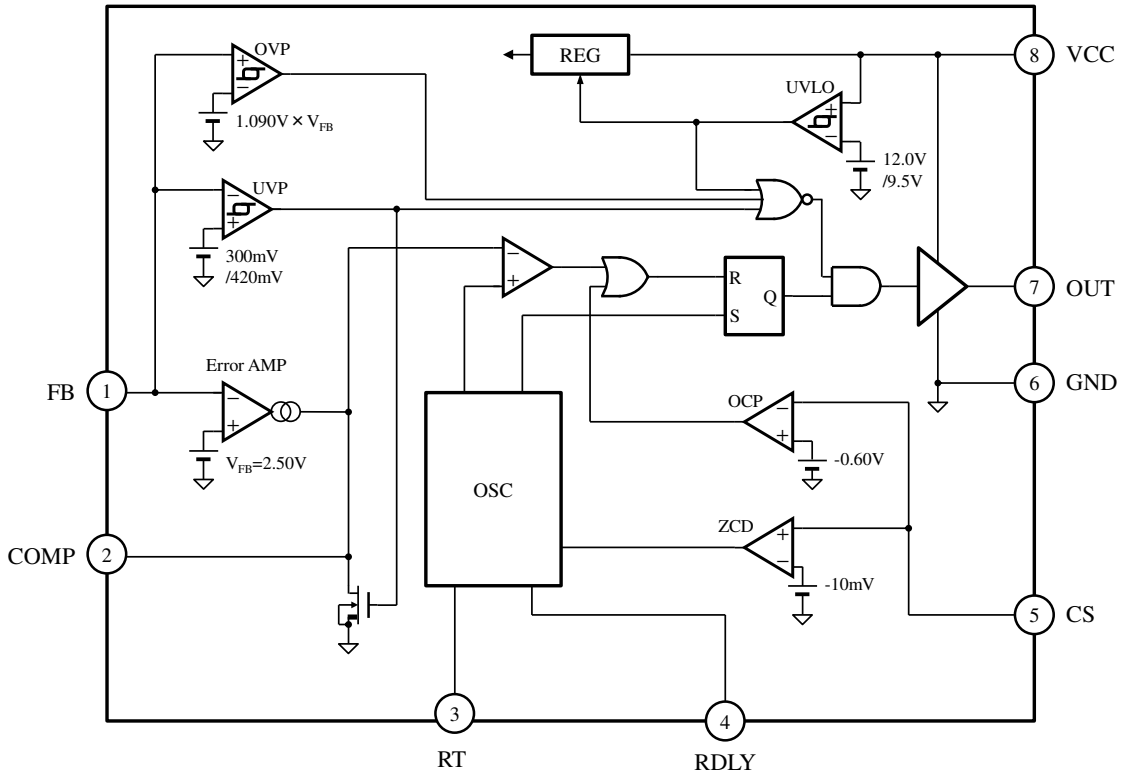
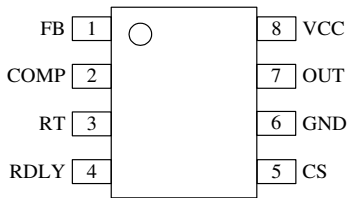

Figure 3-1 Switching time

3. Functional Block Diagram



4. Pin Configuration Definitions



| Number | Name | Function |
|--------|------|--|
| 1 | FB | Feedback signal input, overvoltage protection signal input and FB pin undervoltage protection signal input |
| 2 | COMP | Phase compensation |
| 3 | RT | Maximum on-time adjustment |
| 4 | RDLY | Turn-on delay time adjustment |
| 5 | CS | Overcurrent protection signal input and zero current detection signal input |
| 6 | GND | Ground |
| 7 | OUT | Gate drive output |
| 8 | VCC | Power supply input for control circuit |

5. Typical Application Circuit

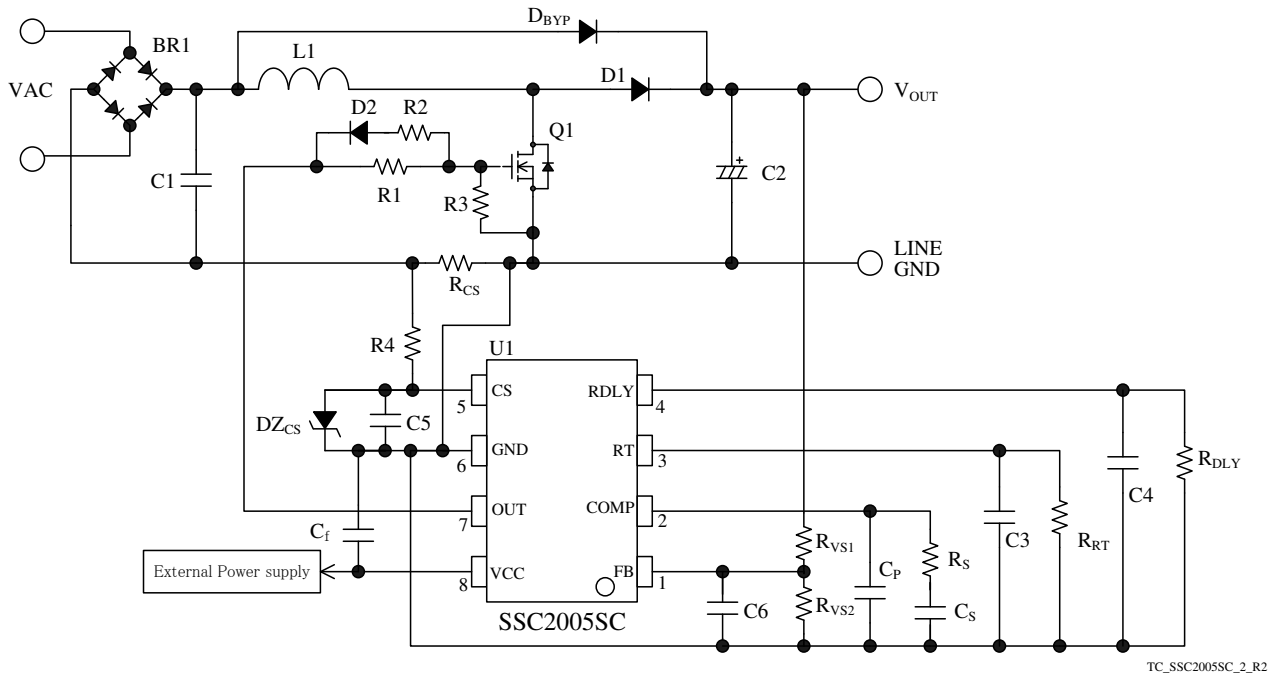

6. Package Outline

SOIC8

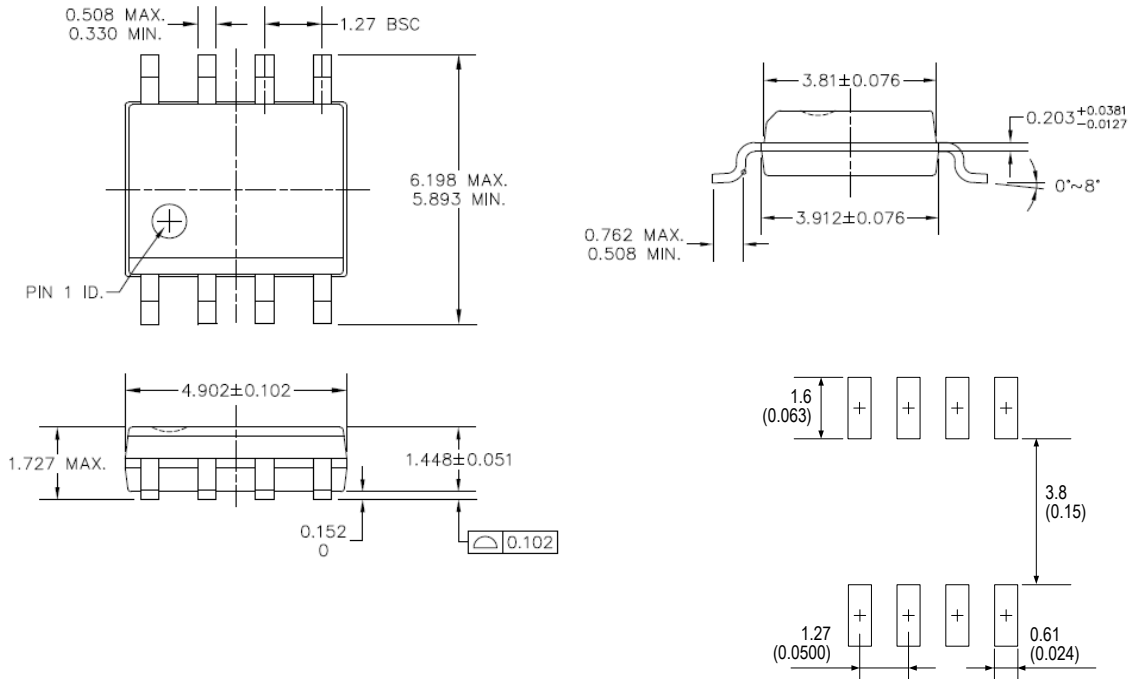

NOTES:

- 1) All liner dimensions are in millimeters
- 2) Pb-free. Device composition compliant with the RoHS directive.

Land Pattern Example (not to scale)

7. Marking Diagram

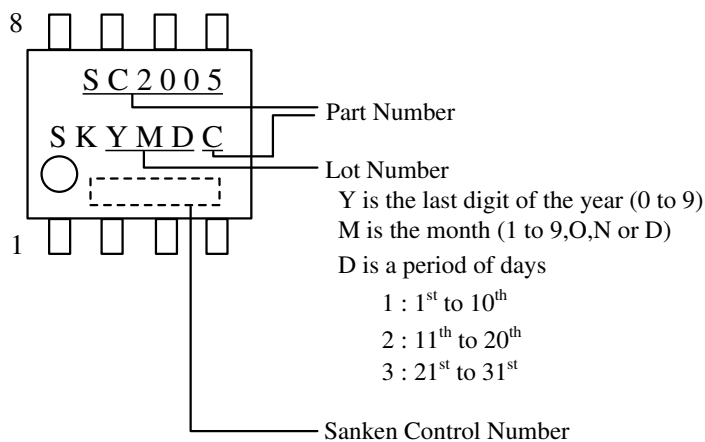

8. Operational Description

- All of the parameter values used in these descriptions are typical values, unless they are specified as minimum or maximum.
- With regard to current direction, "+" indicates sink current (toward the IC) and "-" indicates source current (from the IC).

8.1 Critical Conduction Mode: CRM

Figure 8-1 and Figure 8-2 show the PFC circuit and CRM operation waveform. The IC performs the on/off operation of switching device Q1 in critical mode (the inductor current is zero) as shown in Figure 8-1. Thus, the low drain current variation di/dt of power MOSFET is accomplished. Also, adjusting the turn-on timing at the bottom point of V_{DS} free oscillation waveform (quasi-resonant operation), low noise and high efficiency PFC circuit is realized.

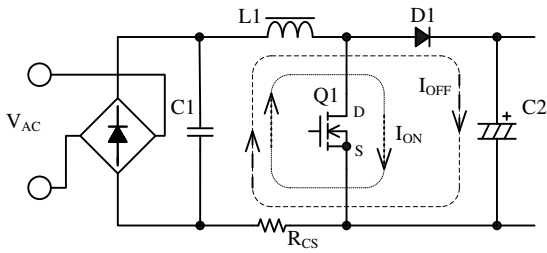

Figure 8-1 PFC circuit

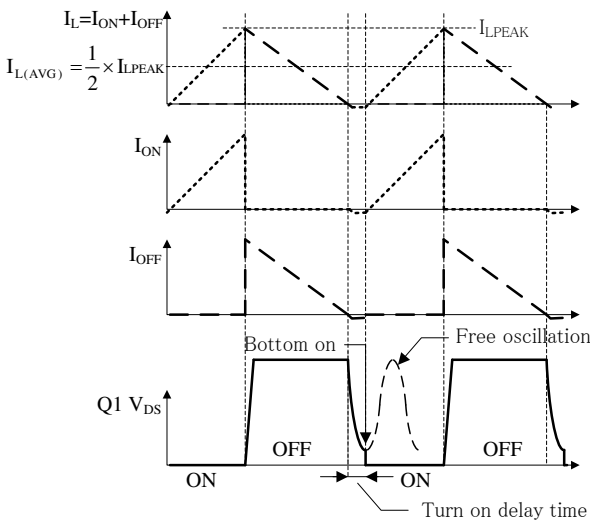

Figure 8-2 CRM operation and bottom on operation

Figure 8-3 shows the internal CRM control circuit. The power MOSFET Q1 starts switching operation by self-oscillation. The control of on-time is as follows: the detection

voltage V_{VS2} is compared with the reference voltage $V_{FB} = 2.50 \text{ V}$ by using error amplifier (Error AMP) connected to FB pin. The output of the Error AMP is averaged and phase compensated. This signal V_{COMP} is compared with the ramp signal V_{OSC} to achieve on-time control. The ON time becomes almost constant in commercial cycle by setting V_{COMP} respond to below 20 Hz (Figure 8-4). This is achieved by tuning the capacitor connected to the COMP pin.

The off-time and the bottom on timing of V_{DS} are set by both zero current detection of drain current and the delay time configured by RDLY pin resistance. Thus, simple PFC circuit with inductor having no auxiliary winding is realized.

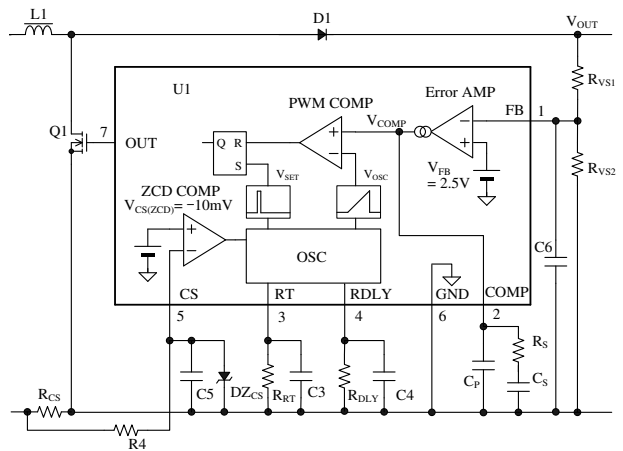

Figure 8-3 CRM control circuit

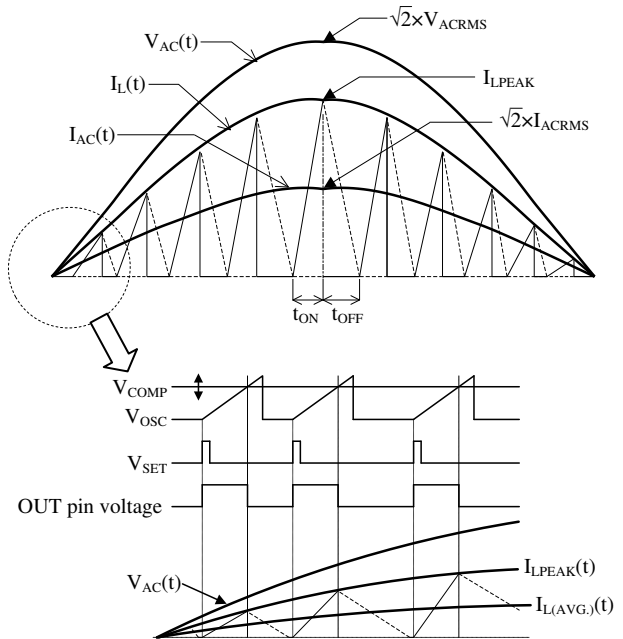

Figure 8-4 CRM operation waveforms

The off duty D_{OFF} of boost converter in CRM mode have the relation of $D_{OFF}(t) = V_{AC}(t)/V_{OUT}$ and is proportional to input voltage, where $V_{AC}(t)$ is the input voltage of AC line as a function of time.

As a result of aforementioned control shown in Figure 8-4, the peak current, I_{LPEAK} , of the inductance current, I_L , becomes sinusoidal. Since the averaged input current become similar to AC input voltage waveform by a low pass filter at input stage, high power factor is achieved.

8.2 Startup Operation

Figure 8-5 shows the VCC pin peripheral circuit.

The VCC pin is a control circuit power supply input. The voltage is supplied by using external power supply. As shown in Figure 8-6, when VCC pin voltage rises to the Operation Start Voltage $V_{CC(ON)} = 12.0$ V, the control circuit starts operation. When the VCC pin voltage decreases to $V_{CC(OFF)} = 9.5$ V, the control circuit stops operation by Undervoltage Lockout (UVLO) circuit, and reverts to the state before startup.

Since COMP pin voltage rises from zero during startup period, the V_{COMP} signal shown in Figure 8-3 gradually rises from low voltage. The on-width gradually increased to restrict the rise of output power by the Softstart Function. Thus, the stress of the peripheral component is reduced.

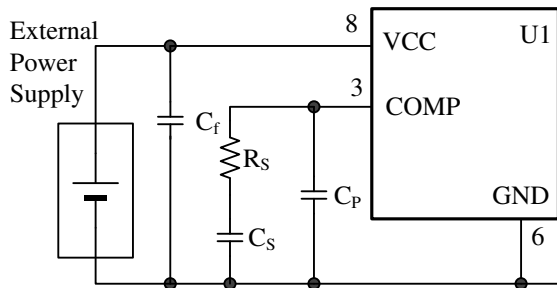

Figure 8-5 VCC pin peripheral circuit

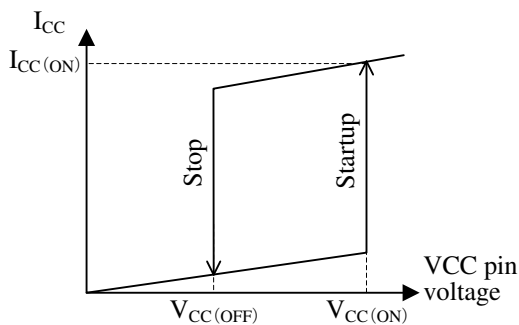

Figure 8-6 Relationship between VCC pin voltage and I_{CC}

8.3 Restart Circuit

The IC is self-oscillation type. The off-time of OUT pin is set by the zero current detection circuit (refer to Section 8.5).

When the off-time of OUT pin is maintained for $t_{RS} = 50 \mu s$ or more, the restart circuit is activated and OUT pin turns on.

At intermittent oscillation period in startup and light load, the restart circuit is activated and the switching operation is stabilized.

Since $t_{RS} = 50 \mu s$ corresponds to the operational frequency of 20 kHz, the minimum frequency should be set to higher than 20 kHz (above audible frequency) at the inductance value design.

8.4 Maximum On-time Setting

In order to reduce audible noise of transformer at transient state, the IC has the Maximum on-time, $t_{ON(MAX)}$. This $t_{ON(MAX)}$ is adjusted by the resistance R_{RT} which is connected to the RT pin.

Figure 8-7 shows the relation between R_{RT} value and $t_{ON(MAX)}$ in IC design. .

The R_{RT} value is set by using the result of $t_{ON(MAX)_OP}$ and Figure 8-7, where $t_{ON(MAX)_OP}$ is the maximum on-time of the peak voltage of the minimum AC input voltage

- $t_{ON(SET)MAX}$ Setting
 I_{LP} is calculated by Equation (1). I_{LP} is peak current of the peak voltage of the minimum AC input voltage.

$$I_{LP} = \frac{2 \times \sqrt{2} \times P_{OUT}}{\eta \times V_{ACRMS(MIN)}} \quad (A) \quad (1)$$

where,

P_{OUT} : Output power (W)

$V_{ACRMS(MIN)}$: Minimum AC input voltage rms value (V)

η : Efficiency of PFC (About 0.90 to 0.97)

$t_{ON(MAX)_OP}$ is calculated by Equation (2) with results of Equation (1) and Equation (5). $t_{ON(MAX)_OP}$ is the maximum on time of the peak voltage of the minimum AC input voltage.

$$t_{ON(MAX)_OP} = \frac{L_P \times I_{LP}}{\sqrt{2} \times V_{ACRMS(MIN)}} \quad (s) \quad (2)$$

where,

L_P : Inductance value of the result of Equation (5)

$V_{ACRMS(MIN)}$: Minimum AC input voltage rms value (V)

- R_{RT} Setting

The value of R_{RT} should set larger than $R_{RT(SET)}$. $R_{RT(SET)}$ is given by $t_{ON(MAX)_OP}$ in Figure 8-7.

The range of R_{RT} is 15 kΩ to 47 kΩ. When $t_{ON(MAX)_OP}$ is 16.3 μs or less, R_{RT} is set 15 kΩ. If $t_{ON(MAX)_OP}$ is 45 μs or more, R_{RT} is over 47 kΩ. Thus, the setting value of $f_{SW(SET)}$ in Equation (5) is increased and the value of L_P should be calculated again.

If the setting value of R_{RT} is too large for $R_{RT(SET)}$, it is necessary to be careful about the audible noise of transformer in the transient operation including startup.

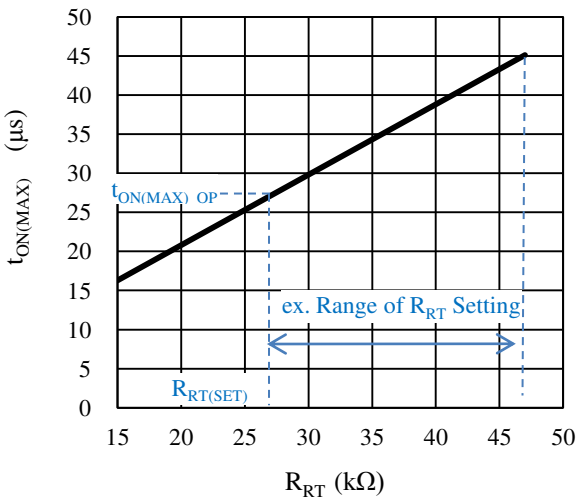

Figure 8-7 $t_{ON(MAX)}$ as a function of R_{RT} (IC design)

8.5 Zero Current Detection and Bottom-on Timing (Delay Time) Setting

Figure 8-8 shows the peripheral circuit of the RDLY pin and the CS pin. Figure 8-9 shows the waveform of each pin.

The off-time and the bottom on timing of V_{DS} are set by both zero current detection of inductor current, I_L and the delay time.

The off-time of a power MOSFET is set by the zero current detection signal of the CS pin and the delay time of the RDLY pin.

Thus, simple PFC circuit with inductor having no auxiliary winding is realized.

The zero current detection signal of inductor current, I_L , is detected by R_{CS} and it is inputted to the CS pin as shown in Figure 8-8. While the power MOSFET is in OFF state, the CS pin voltage decrease to the absolute value of Zero Current Detection Threshold Voltage, $V_{CS(ZCD)} = -10$ V, or less, the OUT pin outputs ON signal after the turn-on delay time, t_{DLY} .

The value of t_{DLY} is determined by the value of the resistor, R_{DLY} , connected to the RDLY pin.

Figure 8-10 shows relationship between R_{DLY} value and t_{DLY} value (IC design). As shown in Figure 8-11, the value of R_{DLY} adjusts the turn-on timing to the bottom

point of V_{DS} free oscillation waveform on actual operation in the application.

Adjusting the output timing of the on signal to the bottom point of V_{DS} free oscillation waveform (quasi-resonant operation), low noise, low switching loss and high efficiency PFC circuit is realized.

The range of R_{DLY} is 15 kΩ to 56 kΩ. The ideal delay time shown in figure 8-11 is given by Equation (3), and it depends on L_P and C_V .

$$t_{ONDLY} \cong \pi\sqrt{L_P \times C_V} \quad (3)$$

where,

L_P : Inductance value of the result of Equation (5).

C_V : Sum of the following capacitance: the output capacitance of power MOSFET, the parasitic capacitance of inductor, and the junction capacitance of boost diode.

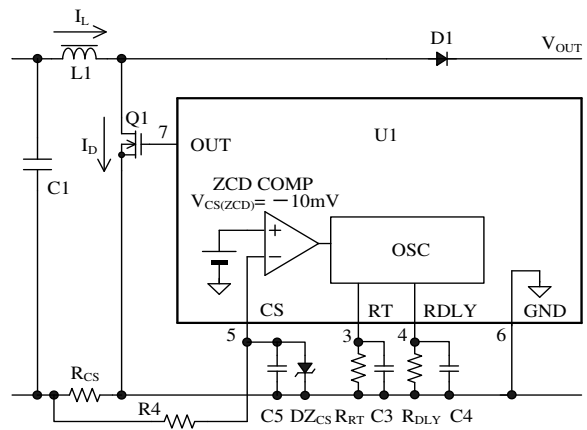

Figure 8-8 The peripheral circuit of the RDLY pin and the CS pin

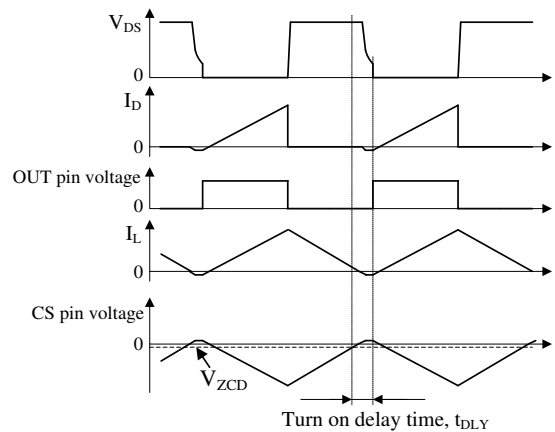

Figure 8-9 Zero current detection waveform

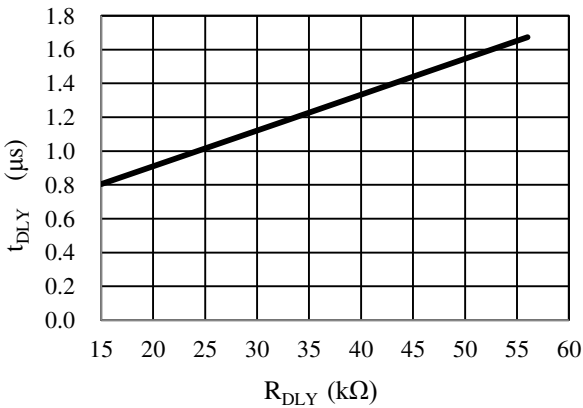

Figure 8-10 t_{DLY} as a function of and R_{DLY} (IC design)

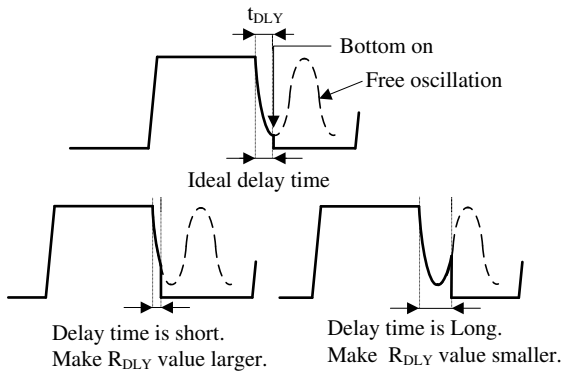

Figure 8-11 Turn-on timing of V_{DS}

8.6 Minimum Off-time Limit Function

In order to prevent the rise of operation frequency at light load, the IC have the Minimum Off-Time t_{OFF(MIN)} = 1.95 μs. If this Minimum Off-Time is shorter than the freewheeling time of inductor, the IC operates in discontinuous condition mode (DCM).

8.7 Overvoltage Protection (OVP)

Figure 8-12 shows the waveforms of Overvoltage Protection (OVP) operation.

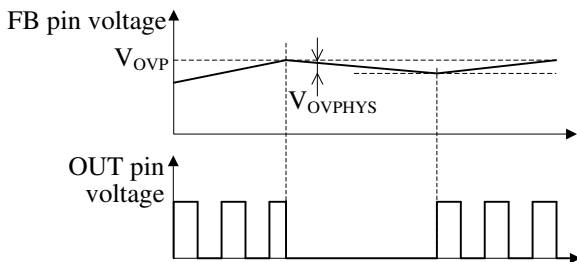

Figure 8-12 Overvoltage protection waveforms

When the FB pin voltage increase to Overvoltage Protection Threshold Voltage, V_{OVP}, OUT pin voltage become Low immediately and the switching operation stops. As a result, the rise of output voltage is prevented. V_{OVP} is 1.090 times the Feedback Control Voltage, V_{FB} = 2.50 V. When the cause of the overvoltage is removed and FB pin voltage decreases to V_{OVP} - V_{OVP(HYS)}, the switching operation restarts.

8.8 FB pin Under Voltage Protection (FB_UVP)

FB pin Under Voltage Protection (FB_UVP) is activated when the FB pin voltage is decreased by the malfunctions in feedback loop such as the open of R_{VS1} or the short of R_{VS2}.

Figure 8-13 shows the FB pin peripheral circuit and internal circuit. When the FB pin voltage is decreased to V_{UVP} = 300 mV or less, the OUT pin output is turned-off immediately and switching operation stops. This prevents the rise of output voltage. When the cause of malfunction is removed and the FB pin voltage rises to V_{UVP} + V_{UVP(HYS)}, the switching operation restarts.

In case the FB pin is open, the FB pin voltage is increase and Overvoltage Protection (OVP) is activated as described in Section 8.7.

When the cause of malfunction is removed and the IC becomes normal control, the switching operation restarts.

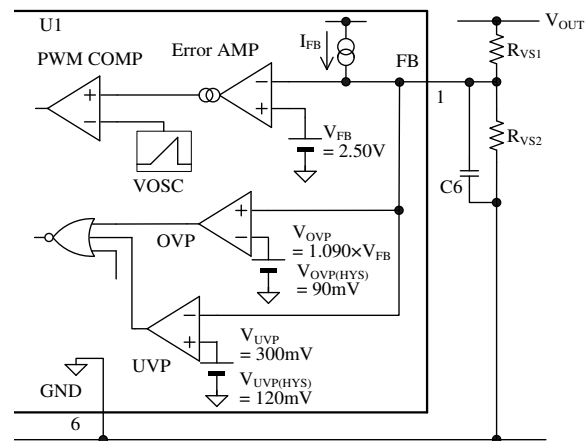

Figure 8-13 The FB pin peripheral circuit and internal circuit.

8.9 Overcurrent Protection (OCP)

Figure 8-14 shows the CS pin peripheral circuit and internal circuit. The inductor current, I_L is detected by the detection resistor, R_{CS} . The detection voltage, V_{RCS} , is fed into the CS pin. The OCP COMP compares the detection voltage, V_{RCS} with Overcurrent Protection Threshold Voltage, $V_{CS(OCP)} = -0.60V$. When V_{RCS} increases to absolute value of $V_{CS(OCP)}$ or more, the OUT pin output is turned-off by pulse-by-pulse.

As shown in Figure 8-14, the CS pin is connected to capacitor-resistor filter (R4 and C5) and zener diode, DZ_{CS} , for the CS pin overvoltage protection.

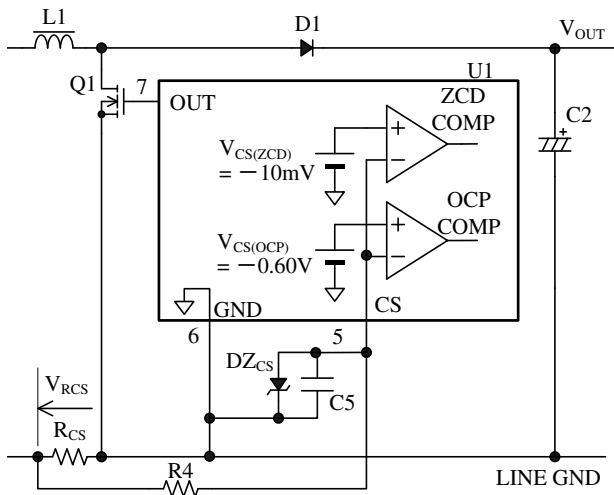

Figure 8-14 The CS pin peripheral circuit and internal circuit.

$$V_{OUT} \geq \sqrt{2} \times V_{ACRMS(MAX)} + V_{DIF} \quad (V) \quad (4)$$

where,

$V_{ACRMS(MAX)}$: Maximum AC input voltage rms value (V)
 V_{DIF} : Boost voltage (About 10V) (V)

2) Operational Frequency, $f_{SW(SET)}$

Determine $f_{SW(SET)}$ that is minimum operational frequency at the peak of the AC line waveform. The frequency becomes higher with lowering the input voltage. The frequency at the peak of the AC line waveform, $f_{SW(SET)}$ should be set more than the audible frequency (20 kHz).

3) Inductance, L_P

Substituting both minimum and maximum of AC input voltage to V_{ACRMS} , choose a smaller one as L_P value.

L_P is calculated as follows:

$$L_P = \frac{\eta \times (V_{ACRMS})^2 \times (V_{OUT} - \sqrt{2} \times V_{ACRMS})}{2 \times P_{OUT} \times f_{SW(SET)} \times V_{OUT}} \quad (H) \quad (5)$$

where,

η : Efficiency of PFC (In general, the range of η is 0.90 to 0.97, depending on on-resistance of power MOSFET $R_{DS(ON)}$ and forward voltage drop of rectifier diode V_F .)

V_{ACRMS} : Maximum/Minimum of AC input voltage rms value (V)

V_{OUT} : Output voltage (V)

P_{OUT} : Output power (W)

$f_{SW(SET)}$: Minimum operational frequency at the peak of the AC line waveform (kHz)

9. Design Notes

9.1 Inductor Setup

Apply proper design margin to temperature rise by core loss and copper loss.

The calculation methods of inductance L_P , is as shown below.

Since the following calculating formulas are approximated, the peak current and the frequency of operational waveforms may be different from the setting value at calculating. Eventually, the inductance value should be adjusted in actual operation.

Apply proper design margin to temperature rise by core loss and copper loss.

1) Output Voltage, V_{OUT}

The output voltage V_{OUT} of boost-converter should be set to a higher value than peak value of input voltage, shown in the following equation:

9.2 External Components

Take care to use properly rated, including derating as necessary and proper type of components.

Figure 9-1 shows the IC peripheral circuit.

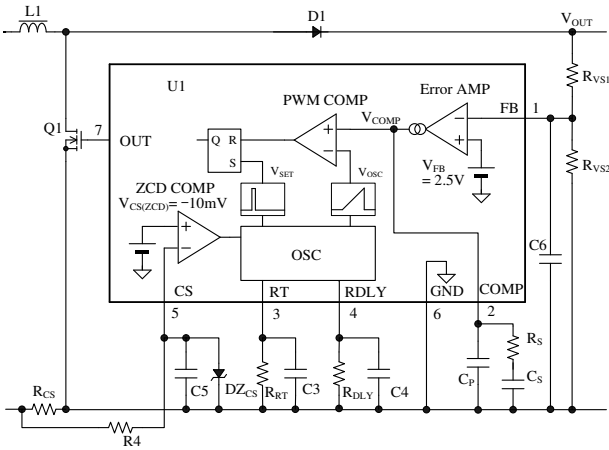

Figure 9-1 The IC peripheral circuit.

● FB Pin Peripheral Circuit (Output Voltage Detection)

The output voltage V_{OUT} is set using R_{VS1} and R_{VS2} . It is expressed by the following equation:

$$V_{OUT} = \left(\frac{V_{FB}}{R_{VS2}} + I_{FB} \right) \times R_{VS1} + V_{FB} \quad (6)$$

where,

- V_{FB} : Feedback reference voltage = 2.50 V
- I_{FB} : Bias current = - 2.0 μ A
- R_{VS}, R_{VS2} : Combined resistance to set V_{OUT} (Ω)

Since R_{VS1} have applied high voltage and have high resistance value, R_{VS1} should be selected from resistors designed against electromigration or use a combination of resistors for that.

The value of capacitor $C6$ between the FB pin and the GND pin is set approximately 100 pF to 3300 pF, in order to reduce the switching noise.

● COMP Pin Peripheral Circuit: R_S , C_S and C_P

Figure 9-1 shows the IC peripheral circuit.

The FB pin voltage is induced into internal Error AMP. The output voltage of the Error AMP is averaged by the COMP pin. The on-time control is achieved by comparing the signal V_{COMP} and the ramp signal V_{OSC} . C_S and R_S adjust the response speed of changing on-time according to output power.

The typical value of C_S and R_S are 1 μ F and 10 k Ω , respectively. When C_S value is too large, the response becomes slow at dynamic variation of output and the output voltage decreases.

Since C_S and R_S affect on the soft-start period at startup, adjustment is necessary in actual operation.

The ripple of output detection signal is averaged by C_P . When the C_P value is too small, the IC operation may become unstable due to the output ripple. The value of capacitor C_P is approximately 0.47 μ F.

● RT Pin Peripheral Circuit: R_{RT} and $C3$

The value of capacitor $C3$ in parallel with R_{RT} is approximately 0.01 μ F, in order to reduce the switching noise.

R_{RT} is 15 k Ω to 47 k Ω for the adjustment of maximum on-time, $t_{ON(MAX)}$.

Refer to Section 8.4 for R_{RT} setting.

● RDLY Pin Peripheral Circuit: R_{DLY} and $C4$

R_{DLY} shown in Figure 9-1 is for the adjustment of the turn-on delay time, t_{DLY} , of the Power MOSFET. As shown in Section 8.5 Zero Current Detection, adjust the value of R_{DLY} and turn-on timing to the bottom point of V_{DS} free oscillation waveform on actual operation in the application. The range of R_{DLY} is 15 k Ω to 56 k Ω .

The value of capacitor $C4$ is approximately 0.01 μ F, in order to reduce the switching noise.

● CS Pin Peripheral Circuit: R_{CS} , $R4$, $C5$ and DZ_{CS}

R_{CS} shown in Figure 9-1 is current sensing resistor. R_{CS} is calculated by the following Equation (7), where Overcurrent Protection Threshold Voltage $V_{CS(OC)}$ is - 0.60 V and I_{LP} is calculated by Equation (1).

$$R_{CS} \leq \frac{|V_{CS(OC)}|}{I_{LP}} \quad (\Omega) \quad (7)$$

The CR filter ($R4$ and $C5$) prevents IC from responding to the drain current surge at power MOSFET turn-on and avoids the unstable operation of the IC.

$R4$ value of approximately 47 Ω is recommended, since the CS Pin Source Current affects the accuracy of OCP detection (see Section 8.5).

$C5$ value is recommended to be calculated by using following equation in which the cut-off frequency of the CR filter ($C5$ and $R4$) is approximately 1 MHz.

$$C5 = \frac{1}{2 \times \pi \times 1 \times 10^6 \times R4} \quad (F) \quad (8)$$

If $R4$ value is 47 Ω , $C5$ value is approximately 3300 pF.

The absolute voltage of the CS pin is -5 V. The CS pin voltage may exceed the absolute value when the startup current to a charge output capacitor, $C2$, flows R_{CS} . Thus, DZ_{CS} is used for the overvoltage protection of the CS pin.

DZ_{CS} value of approximately 3.9 V is recommended. The value should be higher than $V_{CS(OC)}$ and be lower than the CS pin absolute maximum rating of -5 V.

● **OUT Pin Peripheral Circuit (Gate Drive Circuit)**

Figure 9-2 shows the OUT pin peripheral circuit. The OUT pin is the gate drive output which can drive an external power MOSFET directly. The maximum output voltage of the OUT pin is the VCC pin voltage. The maximum current is -500 mA for source and 1 A for sink, respectively. R1 is for source current limiting. Both R2 and D2 are for sink current limiting. The values of these components are adjusted to decrease the ringing of Gate pin voltage and the EMI noise. The reference value is several ohms to several dozen ohms. R3 is used to prevent malfunctions due to steep dv/dt at turn-off of the power MOSFET, and the resistor is connected near the power MOSFET, between the gate and source. The reference value of R3 is from 10 kΩ to 100 kΩ. R1, R2, D2 and R3 are affected by the printed circuit board trace layout and the power MOSFET capacitance. Thus, the optimal values should be adjusted under actual operation of the application.

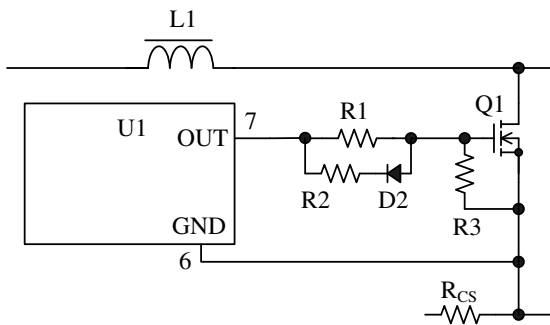

Figure 9-2 The OUT pin peripheral circuit.

● **VCC Pin Peripheral Circuit**

Figure 9-3 shows the VCC pin peripheral circuit. The VCC pin is power supply input. The VCC pin is supplied from an external power. When the VCC pin and the external power supply are distant from each other, placing a film capacitor C_f between the VCC pin and the GND pin is recommended. The value of capacitor C_f is set approximately 0.47 μF, in order to reduce the switching noise.

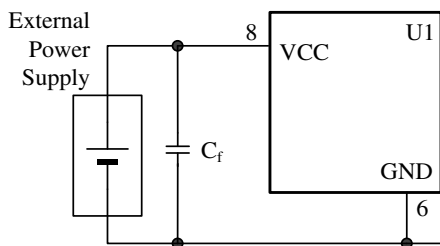

Figure 9-3 The VCC pin peripheral circuit

● **Power MOSFET : Q1**

Choose a power MOSFET having proper margin of V_{DSS} against output voltage, V_{OUT} . The size of heat sink is chosen taking into account some loss by switching and ON resistance of the power MOSFET. The RMS value of drain current, I_{DRMS} is expressed as follows:

$$I_{DRMS} = \frac{2 \times \sqrt{2} \times P_{OUT}}{\eta \times V_{ACRMS(MIN)}} \times \sqrt{\frac{1}{6} - \frac{4 \times \sqrt{2} \times V_{ACRMS(MIN)}}{9 \times \pi \times V_{OUT}}} \quad (A) \quad (9)$$

The loss, $P_{RDS(ON)}$, by on-resistance of the power MOSFET is calculated as follows:

$$P_{RDS(ON)} = (I_{DRSM})^2 \times R_{DS(ON)125^\circ C} \quad (W) \quad (10)$$

where,
 $V_{ACRMS(MIN)}$: Minimum AC input voltage rms value (V)
 P_{OUT} : Output power (W)
 η : Efficiency of PFC
 $R_{DS(ON)125^\circ C}$: ON resistance of the power MOSFET at $T_{ch} = 125^\circ C$ (Ω)

● **Boost Diode: D_{FW}**

Choose a boost diode having proper margin of a peak reverse voltage V_{RSM} against output voltage, V_{OUT} . A fast recovery diode is recommended to reduce the switching noise and loss. Please ask our staff about our lineup. The size of heat sink is chosen taking into account some loss by V_F and recovery current of the boost diode.

The loss of V_F, P_{DFW} , is expressed as follows:

$$P_{DFW} = V_F \times I_{OUT} \quad (W) \quad (11)$$

Where,
 V_F : Forward voltage of boost diode (V)
 I_{OUT} : Out put current (A)

● **Bypass Diode: D_{BYP}**

A Bypass diode protects a boost diode from a large current such as an inrush current. A high surge current tolerance diode is recommended. Please ask our staff about our lineup.

● **Output Capacitor: C2**

Apply proper design margin to accommodate the ripple current, the ripple voltage and the temperature rise. Use of high ripple current and low impedance types, designed for switch-mode power supplies, is recommended, depending on their purposes.

C2 is calculated by both Equation (12) and (14), and is selected the large value of them.

1) Given the C2 ripple voltage $V_{OUTRIPPLE}$ (V_{PP}) (10 V_{PP} for example), C2 is expressed as follows:

$$C2 > \frac{I_{OUT}}{2 \times \pi \times f_{LINE} \times V_{OUT(RI)}} \quad (F) \quad (12)$$

where,

f_{LINE} :Line frequency (Hz)

I_{OUT} :Output current (A)

The C2 voltage is expressed by Equation (13).

When the output ripple is high, the V_{C2} voltage may reach to Overvoltage Protection voltage, V_{OVP} , in near the maximum value of V_{C2} , or input current waveform may be distorted due to the stop of the boost operation in near the minimum value of V_{C2} . It is necessary to select large C2 value or change the setting of output voltage (boost voltage).

$$V_{C2} = V_{OUT} \pm \frac{V_{OUT(RI)}}{2} \quad (V) \quad (13)$$

2) Given the output hold time as t_{HOLD} (s), C2 is expressed as follows:

$$C2 > \frac{2 \times P_{OUT} \times t_{HOLD}}{\left((V_{OUT})^2 - (V_{OUT(MIN)})^2 \right)} \quad (F) \quad (14)$$

where,

t_{HOLD} : Output hold time (s)

$V_{OUT(MIN)}$: Minimum output voltage of C2 during output hold (V)

η : Efficiency

9.3 PCB Trace Layout and Component Placement

Since the PCB circuit trace design and the component layout significantly affects operation, EMI noise, and power dissipation, the high frequency PCB trace should be low impedance with small loop and wide trace.

In addition, the ground traces affect radiated EMI noise, and wide, short traces should be taken into account.

Figure 9-4 shows the circuit design example. Figure 9-5 shows the PCB pattern layout example around the IC.

(1) **Main Circuit Trace**

This is the main trace containing switching currents, and thus it should be as wide trace and small loop as possible.

(2) **Control Ground Trace Layout**

Since the operation of the IC may be affected from the large current of the main trace that flows in control ground trace, the control ground trace should be separated from main trace and connected at a single point grounding of point A in Figure 9-4 as close to the R_{CS} as possible.

(3) **R_{CS} Trace Layout**

R_{CS} should be placed as close as possible to the Source pin and the CS pin.

The peripheral components of the CS pin should be connected by dedicated pattern from root of R_{CS} .

The connection between the power ground of the main trace and the IC ground should be at a single point ground which is close to the base of R_{CS} .

(4) **Peripheral Component of the IC**

The components for control connected to the IC should be placed as close as possible to the IC, and should be connected as short as possible to the each pin.

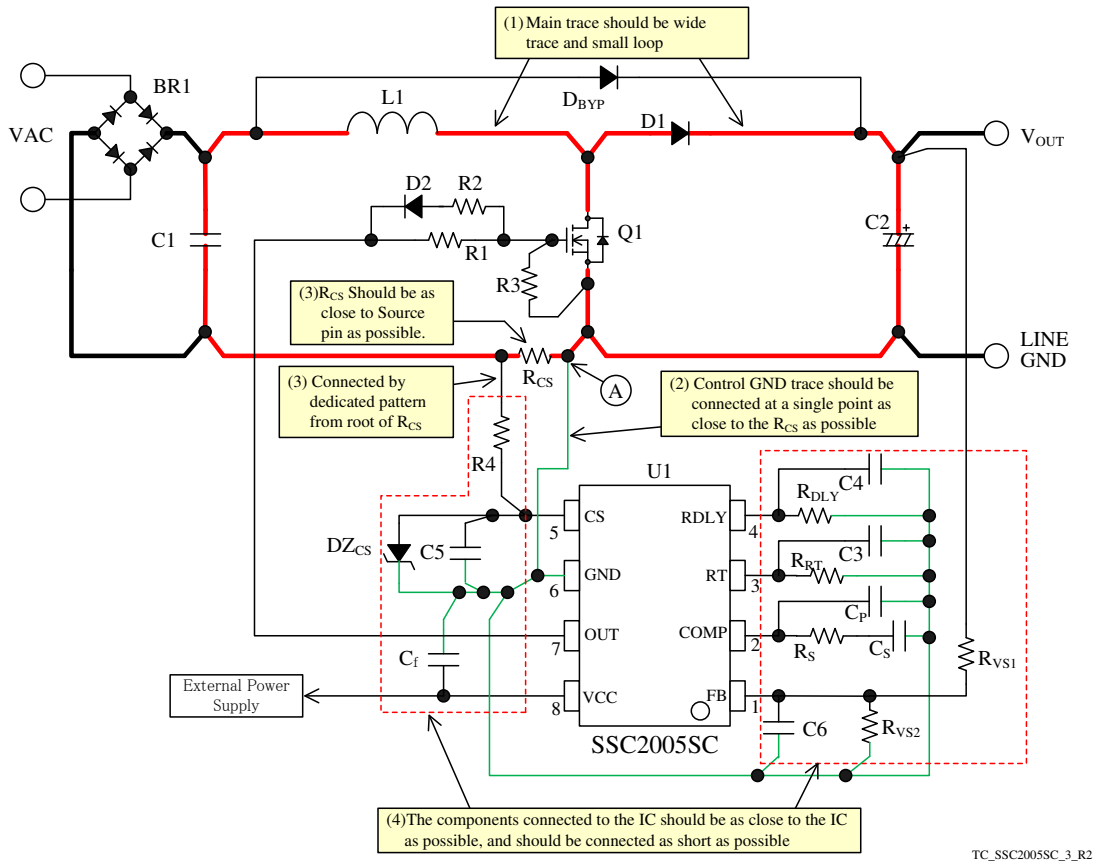

Figure 9-4 Example of connection of peripheral component

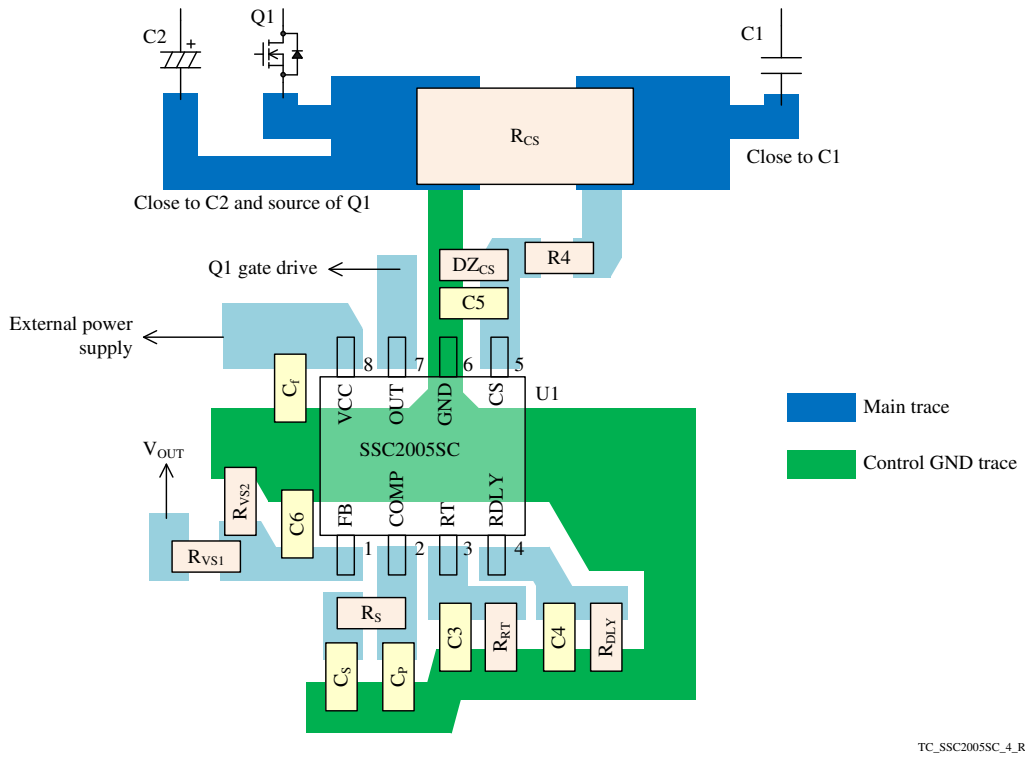

Figure 9-5 Example of connection of peripheral component

10. Reference Design of Power Supply

As an example, the following show the power supply specification, the circuit schematic, the bill of materials.

● Circuit schematic

| | |
|---|-------------------|
| IC | SSC2005SC |
| Input voltage | AC 85 to AC 265 V |
| Output power | 200 W |
| Output voltage | 390 V |
| Minimum operational frequency at the peak of the AC line waveform | 40 kHz (AC 265 V) |
| Efficiency | 0.95 |

● Circuit schematic

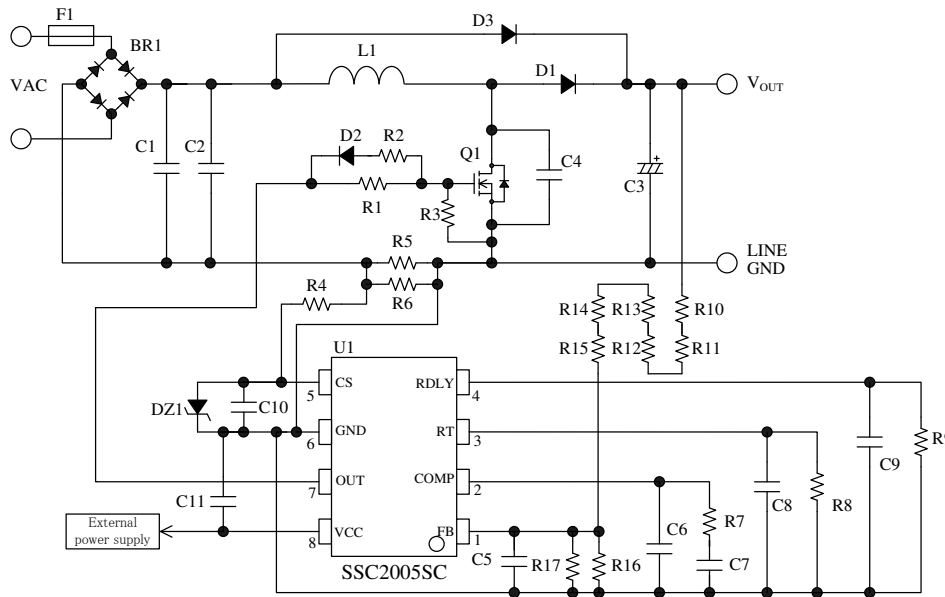

TC_SSC2005SC_5_R1

● Bill of materials

| Symbol | Part type | Ratings ⁽¹⁾ | Recommended Sanken Parts | Symbol | Part type | Ratings ⁽¹⁾ | Recommended Sanken Parts |
|-------------------|-----------|------------------------|--------------------------|--------------------|---------------|------------------------|--------------------------|
| BR1 | General | 600 V | | R5 | General | 0.15 Ω, 2W | |
| F1 | Fuse | AC 250 V | | R6 | General | 0.15 Ω, 2W | |
| L1 | Inductor | 170 μH (EI30) | | R7 | General | 10 kΩ | |
| C1 | Ceramic | 450 V, 0.68 μF | | R8 | General | 15kΩ | |
| C2 | Ceramic | 450 V, 0.68 μF | | R9 ⁽²⁾ | General | 15kΩ | |
| C3 ⁽²⁾ | Ceramic | 450 V, 180 μF | | R10 ⁽³⁾ | General | 180 kΩ, 1% | |
| C4 ⁽²⁾ | Ceramic | 1kV, 100pF | | R11 ⁽³⁾ | General | 820 kΩ, 1% | |
| C5 | Ceramic | 1000 pF | | R12 ⁽³⁾ | General | 560 kΩ, 1% | |
| C6 | Ceramic | 0.47 μF | | R13 ⁽³⁾ | General | 560 kΩ, 1% | |
| C7 | Ceramic | 1 μF | | R14 ⁽³⁾ | General | 680 kΩ, 1% | |
| C8 | Ceramic | 0.01 μF | | R15 ⁽³⁾ | General | 680 kΩ, 1% | |
| C9 | Ceramic | 0.01 μF | | R16 ⁽²⁾ | General | Open | |
| C10 | Ceramic | 3300 pF | | R17 | General | 22 kΩ, 1% | |
| C11 | Ceramic | 0.47 μF | | D1 | Fast recovery | 600V, 10 A | FMNS-1106S |
| R1 ⁽²⁾ | General | 100 Ω | | D2 | Schottky | 60 V, 0.7 A | AK06 |
| R2 ⁽²⁾ | General | 10 Ω | | D3 | General | 600V, 1.2A | RM10A |
| R3 ⁽²⁾ | General | 100 kΩ | | U1 | IC | | SSC2005SC |
| R4 | General | 47 Ω | | | | | |

⁽¹⁾ Unless otherwise specified, the voltage rating of capacitor is 50 V or less and the power rating of resistor is 1/8 W or less.

⁽²⁾ It is necessary to be adjusted based on actual operation in the application.

⁽³⁾ Resistors applied high DC voltage and of high resistance are recommended to select resistors designed against electromigration or use combinations of resistors in series for that to reduce each applied voltage, according to the requirement of the application.

OPERATING PRECAUTIONS

In the case that you use Sanken products or design your products by using Sanken products, the reliability largely depends on the degree of derating to be made to the rated values. Derating may be interpreted as a case that an operation range is set by derating the load from each rated value or surge voltage or noise is considered for derating in order to assure or improve the reliability. In general, derating factors include electric stresses such as electric voltage, electric current, electric power etc., environmental stresses such as ambient temperature, humidity etc. and thermal stress caused due to self-heating of semiconductor products. For these stresses, instantaneous values, maximum values and minimum values must be taken into consideration. In addition, it should be noted that since power devices or IC's including power devices have large self-heating value, the degree of derating of junction temperature affects the reliability significantly.

Because reliability can be affected adversely by improper storage environments and handling methods, please observe the following cautions.

Cautions for Storage

- Ensure that storage conditions comply with the standard temperature (5 to 35°C) and the standard relative humidity (around 40 to 75%); avoid storage locations that experience extreme changes in temperature or humidity.
- Avoid locations where dust or harmful gases are present and avoid direct sunlight.
- Reinspect for rust on leads and solderability of the products that have been stored for a long time.

Cautions for Testing and Handling

When tests are carried out during inspection testing and other standard test periods, protect the products from power surges from the testing device, shorts between the product pins, and wrong connections. Ensure all test parameters are within the ratings specified by Sanken for the products.

Soldering

- When soldering the products, please be sure to minimize the working time, within the following limits:
 - 260 ± 5 °C 10 ± 1 s (Flow, 2 times)
 - 380 ± 10 °C 3.5 ± 0.5 s (Soldering iron, 1 time)

Electrostatic Discharge

- When handling the products, the operator must be grounded. Grounded wrist straps worn should have at least 1MΩ of resistance from the operator to ground to prevent shock hazard, and it should be placed near the operator.
- Workbenches where the products are handled should be grounded and be provided with conductive table and floor mats.
- When using measuring equipment such as a curve tracer, the equipment should be grounded.
- When soldering the products, the head of soldering irons or the solder bath must be grounded in order to prevent leak voltages generated by them from being applied to the products.
- The products should always be stored and transported in Sanken shipping containers or conductive containers, or be wrapped in aluminum foil.

IMPORTANT NOTES

- The contents in this document are subject to changes, for improvement and other purposes, without notice. Make sure that this is the latest revision of the document before use.
- Application examples, operation examples and recommended examples described in this document are quoted for the sole purpose of reference for the use of the products herein and Sanken can assume no responsibility for any infringement of industrial property rights, intellectual property rights, life, body, property or any other rights of Sanken or any third party which may result from its use.
- Unless otherwise agreed in writing by Sanken, Sanken makes no warranties of any kind, whether express or implied, as to the products, including product merchantability, and fitness for a particular purpose and special environment, and the information, including its accuracy, usefulness, and reliability, included in this document.
- Although Sanken undertakes to enhance the quality and reliability of its products, the occurrence of failure and defect of semiconductor products at a certain rate is inevitable. Users of Sanken products are requested to take, at their own risk, preventative measures including safety design of the equipment or systems against any possible injury, death, fires or damages to the society due to device failure or malfunction.
- Sanken products listed in this document are designed and intended for the use as components in general purpose electronic equipment or apparatus (home appliances, office equipment, telecommunication equipment, measuring equipment, etc.).
When considering the use of Sanken products in the applications where higher reliability is required (transportation equipment and its control systems, traffic signal control systems or equipment, fire/crime alarm systems, various safety devices, etc.), and whenever long life expectancy is required even in general purpose electronic equipment or apparatus, please contact your nearest Sanken sales representative to discuss, prior to the use of the products herein.
The use of Sanken products without the written consent of Sanken in the applications where extremely high reliability is required (aerospace equipment, nuclear power control systems, life support systems, etc.) is strictly prohibited.
- When using the products specified herein by either (i) combining other products or materials therewith or (ii) physically, chemically or otherwise processing or treating the products, please duly consider all possible risks that may result from all such uses in advance and proceed therewith at your own responsibility.
- Anti radioactive ray design is not considered for the products listed herein.
- Sanken assumes no responsibility for any troubles, such as dropping products caused during transportation out of Sanken's distribution network.
- The contents in this document must not be transcribed or copied without Sanken's written consent.