



Chipsmall Limited consists of a professional team with an average of over 10 year of expertise in the distribution of electronic components. Based in Hongkong, we have already established firm and mutual-benefit business relationships with customers from,Europe,America and south Asia,supplying obsolete and hard-to-find components to meet their specific needs.

With the principle of "Quality Parts,Customers Priority,Honest Operation,and Considerate Service",our business mainly focus on the distribution of electronic components. Line cards we deal with include Microchip,ALPS,ROHM,Xilinx,Pulse,ON,Everlight and Freescale. Main products comprise IC,Modules,Potentiometer,IC Socket,Relay,Connector.Our parts cover such applications as commercial,industrial, and automotives areas.

We are looking forward to setting up business relationship with you and hope to provide you with the best service and solution. Let us make a better world for our industry!



## Contact us

Tel: +86-755-8981 8866 Fax: +86-755-8427 6832

Email & Skype: info@chipsmall.com Web: www.chipsmall.com

Address: A1208, Overseas Decoration Building, #122 Zhenhua RD., Futian, Shenzhen, China



# Discontinuous Conduction Mode (DCM) Interleaved PFC IC SSC2102S

## General Descriptions

SSC2102S is controller ICs intended to implement a DCM (Discontinuous Conduction Mode) interleaved PFC (Power Factor Correction) circuit.

Using the two-phase interleaved control incorporated in this IC, it is possible to achieve a low cost, high performance PFC system with low input / output ripple currents, low noises and few external components.

## Features

- No Auxiliary Windings on Inductors Required
- Voltage Mode Control
- Maximum ON Time Control Circuit
- Soft-start Function
- Built-in High Speed Response Function (HSR)
- Protections
  - Dual level Overcurrent Protection (OCP) Pulse-by Pulse
  - Dual level Overvoltage Protection (OVP)---Auto-Restart
  - Under Voltage Protection (UVP) ----- Auto-Restart
  - Thermal Shutdown with Hysteresis (TSD)
    - Auto-Restart
  - Open Loop Detection (OLD) ----- Auto-Restart
  - VFB pin /VIN pin / IS pin Open Pin Protection (OPP)

## Package

SOP8

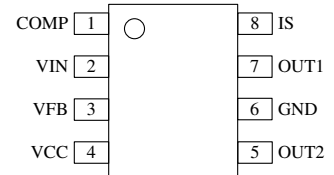

Not to scale

## Electrical Characteristics

Maximum ON Time,  $t_{ONMAX} = 20.7 \mu s$ (typ.)  
 Error Amplifier Reference Voltage,  $V_{FB(REF)} = 3.5 V$ (typ.)  
 OUT Pin Peak Source Current,  $I_{OUT(SO)} = -0.5 A^*$   
 OUT Pin Peak Sink Current,  $I_{OUT(SI)} = 0.5 A^*$

\*Design assurance item

## Typical Application Circuit

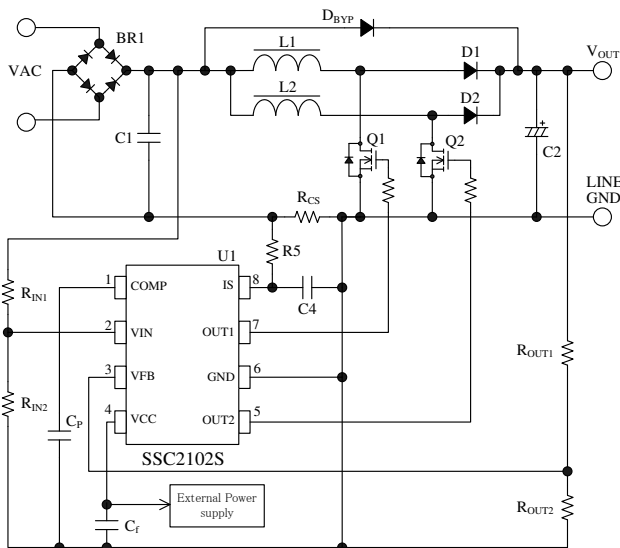

## Applications

PFC Circuit up to 300 W of Output Power such as:

- AC/DC Power Supply
- Digital Appliances (Large Size LCD Television and so forth)
- OA Equipment (Computer, Server, Monitor, and so forth)
- Communication Facilities
- Other SMPS

## CONTENTS

General Descriptions	1
1. Absolute Maximum Ratings	3
2. Electrical Characteristics	3
3. Functional Block Diagram	6
4. Pin Configuration Definitions	6
5. Typical Application Circuit	7
6. Package Outline	8
7. Marking Diagram	8
8. Operational Description	9
8.1 Operational Description of Interleaved DCM	9
8.2 Startup Operation	9
8.3 Voltage Control Operation	10
8.4 High Speed Response Function (HSR)	11
8.5 Gate Drive	12
8.6 Overcurrent Protection (OCP)	12
8.7 Overvoltage Protection (OVP)	13
8.8 Open Loop Detection (OLD)	14
8.9 Open Pin Protection (OPP)	14
8.10 Input Undervoltage Protection (UVP)	14
8.11 Thermal Shutdown (TSD)	14
9. Parameters Design	15
9.1 Inductor Design	15
9.2 Overcurrent Detection Resistor, $R_{CS}$	17
10. Design Notes	18
10.1 External Components	18
10.2 PCB Trace Layout and Component Placement	18
OPERATING PRECAUTIONS	20
IMPORTANT NOTES	21

## 1. Absolute Maximum Ratings

- The polarity value for current specifies a sink as "+," and a source as "-," referencing the IC.
- Unless otherwise specified  $T_A = 25\text{ }^\circ\text{C}$

Parameter	Symbol	Test Conditions	Pins	Rating	Units
COMP Pin Voltage	$V_{COMP}$		1 – 6	– 0.3 to 5.5	V
VIN Pin Voltage	$V_{IN}$		2 – 6	– 0.3 to 5.5	V
VIN Pin Current	$I_{IN}$		2 – 6	– 1 to 1	mA
VFB Pin Voltage	$V_{FB}$		3 – 6	– 0.3 to 5.5	V
VFB Pin Current	$I_{FB}$		3 – 6	– 1 to 1	mA
VCC Pin Voltage	$V_{CC}$		4 – 6	– 0.3 to 30	V
OUT2 Pin Voltage	$V_{DR2}$		5 – 6	– 0.3 to 30	V
OUT1 Pin Voltage	$V_{DR1}$		7 – 6	– 0.3 to 30	V
IS Pin Voltage	$V_{IS}$		8 – 6	– 16.0 to 5.5	V
IS Pin Current	$I_{IS}$		8 – 6	– 1.75 to 1	mA
Operating Frame Temperature	$T_{FOP}$		–	– 40 to 85	$^\circ\text{C}$
Storage Temperature	$T_{stg}$			– 40 to 125	$^\circ\text{C}$
Junction Temperature	$T_j$		–	– 40 to 125	$^\circ\text{C}$

## 2. Electrical Characteristics

- The polarity value for current specifies a sink as "+," and a source as "-," referencing the IC.
- Unless otherwise specified,  $T_A = 25\text{ }^\circ\text{C}$ ,  $V_{CC} = 15\text{ V}$

Parameter	Symbol	Test Conditions	Pins	Min.	Typ.	Max.	Units
<b>Power Supply Startup Operation</b>							
Operation Start Voltage	$V_{CC(ON)}$		4 – 6	10.8	11.6	12.4	V
Operation Stop Voltage	$V_{CC(OFF)}$		4 – 6	9.8	10.6	11.4	V
VCC Pin Voltage Hysteresis	$V_{CC(HYS)}$		4 – 6	0.8	1.0	1.2	V
Circuit Current in Pre-operation	$I_{CC(OFF)}$	$V_{CC} = 11\text{ V}$	4 – 6	–	40	100	$\mu\text{A}$
Circuit Current in Operation	$I_{CC(ON)}$		4 – 6	–	11.0	15.0	mA
Circuit Current in Overvoltage Protection Operation	$I_{CC(OVP)}$	$V_{FB} = 3.9\text{ V}$	4 – 6	–	8.0	10.0	mA
Circuit Current in Standby Operation	$I_{CC(Standby)}$	$V_{FB} = 0.5\text{ V}$	4 – 6	–	100	200	$\mu\text{A}$
<b>Oscillation Control</b>							
OUT1 Pin Maximum ON Time	$t_{ONMAX}$		7 – 6	19.2	20.7	22.2	$\mu\text{s}$
On-time matching between OUT1 and OUT1	$t_{RATIO}$		5 – 6 7 – 6	– 5	0	5	%
OUT1 Pin and OUT2 pin Phase Difference	PHASE		5 – 6 7 – 6	170	180	190	deg

Parameter	Symbol	Test Conditions	Pins	Min.	Typ.	Max.	Units
<b>Error Amplifier Operation</b>							
Error Amplifier Reference Voltage	$V_{FB(REF)}$		3-6	3.4	3.5	3.6	V
Error Amplifier Transconductance Gain	$g_{mEA}$		—	80	100	120	$\mu S$
Error Amplifier Maximum Source Current	$I_{COMP(SO)}$	$V_{FB} = 2.8 V$	1-6	-36	-30	-24	$\mu A$
Error Amplifier Maximum Voltage	$V_{COMP(MAX)}$	$V_{FB} = 3.0 V$	1-6	4.00	4.12	4.25	V
VFB Pin High Speed Response Enable Voltage <sup>(1)</sup>	$V_{FB(HSR)EN}$		3-6	3.3	3.4	3.5	V
VFB Pin High Speed Response Activating Voltage	$V_{FB(HSR)AC}$		3-6	3.1	3.2	3.3	V
COMP Pin Source Current in High Speed Response Operation	$I_{COMP(SO)HSR}$	$V_{FB} = 2.5 V$	1-6	-120	-100	-80	$\mu A$
VFB Pin Input Bias Current	$I_{FB(BIAS)}$	$V_{FB} = 3.5 V$	3-6	—	—	1.5	$\mu A$
COMP Pin Voltage in Output Open Loop Detection Operation	$V_{COMP(OLD)}$	$I_{COMP} = 100 \mu A$	1-6	0.7	0.9	1.1	V
<b>Drive Output</b>							
OUT1 and OUT2 Pin Voltage (Low)	$V_{OUT(L)}$	$I_{OUT} = 20 mA$	5-6 7-6	-	-	0.3	V
OUT1 and OUT2 Pin Voltage (High)	$V_{OUT(H)}$	$V_{CC} = 12 V$	5-6 7-6	-	10.2	-	V
OUT1 and OUT2 Pin Rise Time <sup>(2)</sup>	$t_r$	$V_{CC} = 20 V$	5-6 7-6	-	70	-	ns
OUT1 and OUT2 Pin Fall Time <sup>(2)</sup>	$t_f$	$V_{CC} = 20 V$	5-6 7-6	-	35	-	ns
OUT1 and OUT2 Pin Peak Source Current <sup>(1)</sup>	$I_{OUT(SO)}$		5-6 7-6	-	-0.5	-	A
OUT1 and OUT2 Pin Peak Sink Current <sup>(1)</sup>	$I_{OUT(SI)}$		5-6 7-6	-	0.5	-	A

<sup>(1)</sup> Design assurance item

<sup>(2)</sup> Shown in Figure 3-1

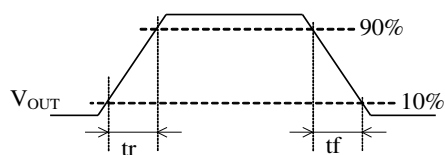

Figure 3-1 Switching time

Parameter	Symbol	Test Conditions	Pins	Min.	Typ.	Max.	Units
<b>Protection Operation</b>							
VFB Pin Output Open Loop Detection Voltage	$V_{FB(OLDL)}$		3 – 6	0.46	0.50	0.54	V
VFB Pin Output Open Loop Detection Release Voltage	$V_{FB(OLDH)}$		3 – 6	0.64	0.70	0.76	V
VFB Pin Soft Overvoltage Protection Threshold Voltage	$V_{FB(SOVP)}$		3 – 6	3.60	3.68	3.76	V
VFB Pin Overvoltage Protection Threshold Voltage	$V_{FB(OVP)}$		3 – 6	3.64	3.72	3.80	V
IS Pin Overcurrent Protection Threshold Voltage (Low)	$V_{IS(OCPL)}$		8 – 6	- 0.48	- 0.42	- 0.36	V
IS Pin Overcurrent Protection Threshold Voltage (High)	$V_{IS(OCPH)}$		8 – 6	- 0.62	- 0.55	- 0.48	V
COMP Sink Current in Protection Mode	$I_{COMP(SI)}$	$V_{IS} = - 0.5 \text{ V}$	1 – 6	80	100	120	$\mu\text{A}$
VIN Pin Protection Threshold Voltage	$V_{IN(P)}$		2 – 6	0.1	0.3	0.5	V
VIN Pin Protection Delay Time	$t_{VIN}$		2 – 6	7	14	21	ms
Thermal Shutdown Activating Temperature <sup>(1)</sup>	$T_{jTSDH}$		-	150	-	-	$^{\circ}\text{C}$
Thermal Shutdown Release Temperature <sup>(1)</sup>	$T_{jTSDL}$		-	140	-	-	$^{\circ}\text{C}$
Hysteresis Temperature of Thermal Shutdown <sup>(1)</sup>	$T_{jTSDHYS}$		-	-	10	-	$^{\circ}\text{C}$
<b>Thermal Resistance</b>							
Thermal Resistance from Junction to Frame	$\theta_{j-F}$		-	-	65	85	$^{\circ}\text{C}/\text{W}$

<sup>(1)</sup> Design assurance item



### 3. Functional Block Diagram

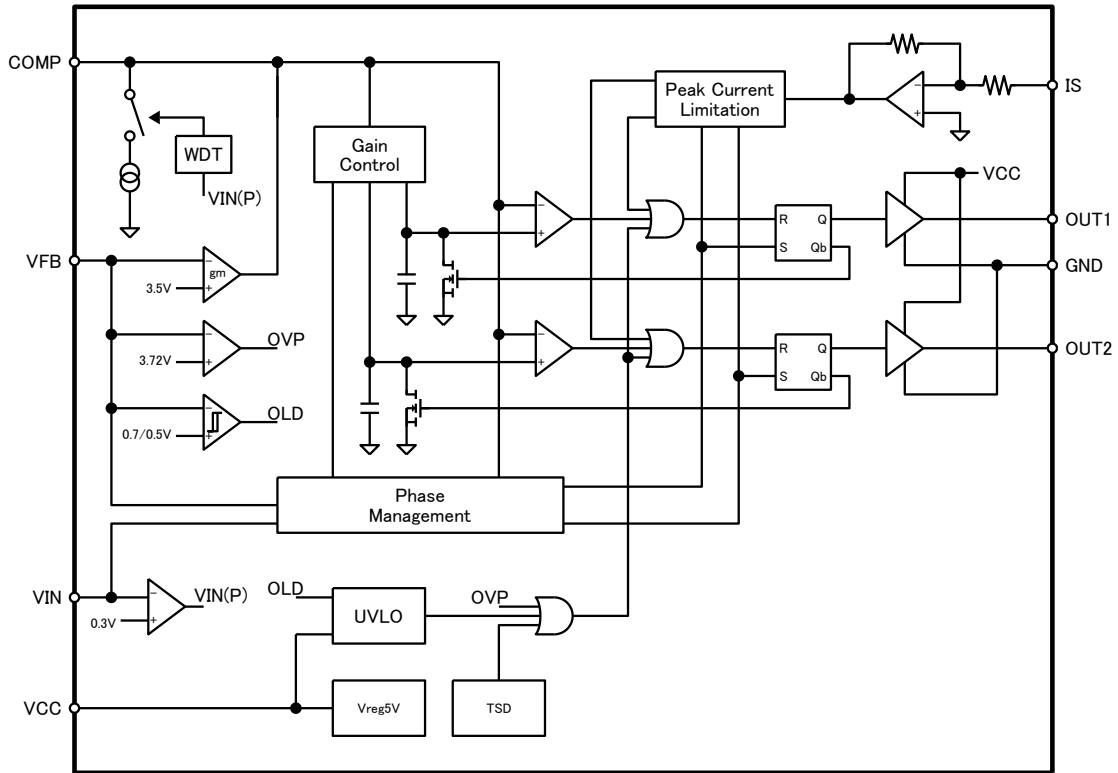

### 4. Pin Configuration Definitions

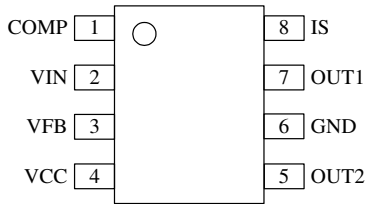

Pin	Name	Descriptions
1	COMP	Error amplifier output and phase compensation
2	VIN	Rectified input voltage detection
3	VFB	Constant voltage control signal input / Overvoltage signal input / Open loop detection signal input
4	VCC	Power supply for control circuit input
5	OUT2	2nd Gate driver output
6	GND	Ground
7	OUT1	1st Gate driver output
8	IS	Peak current detection signal input

5. Typical Application Circuit

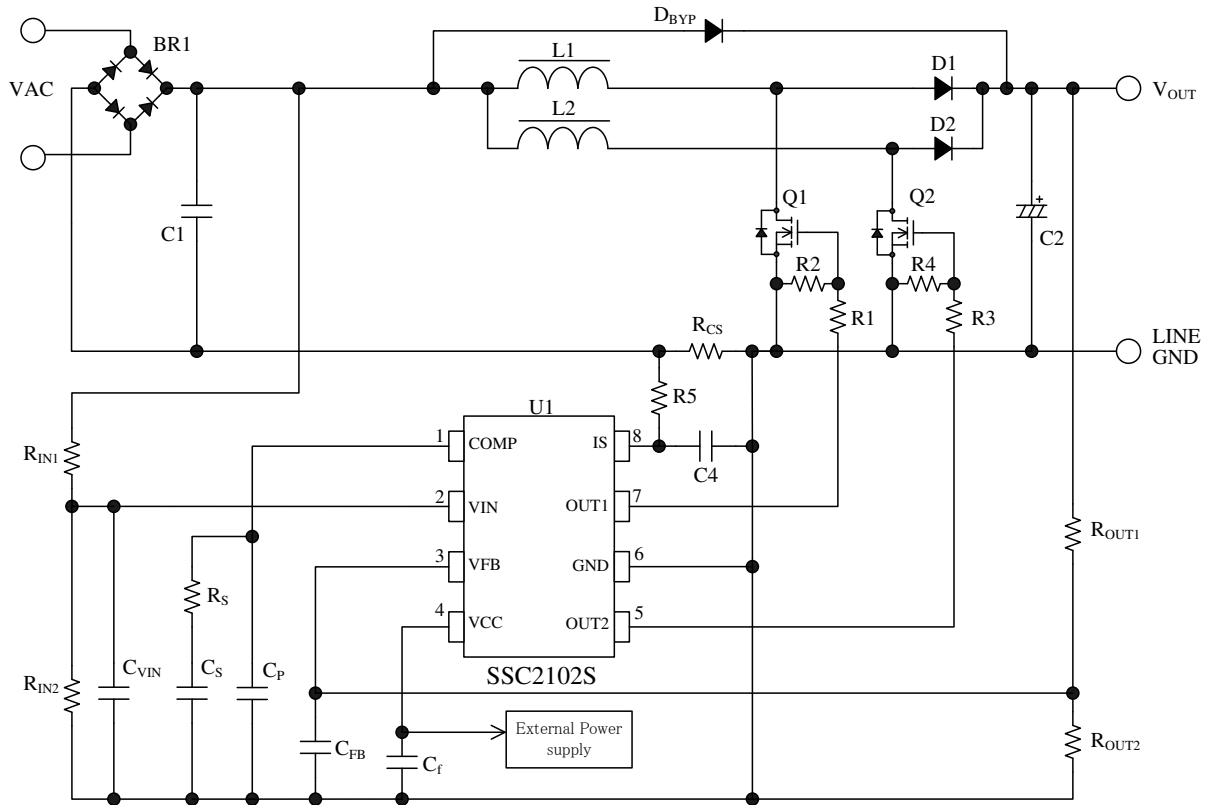



6. Package Outline

SOIC8

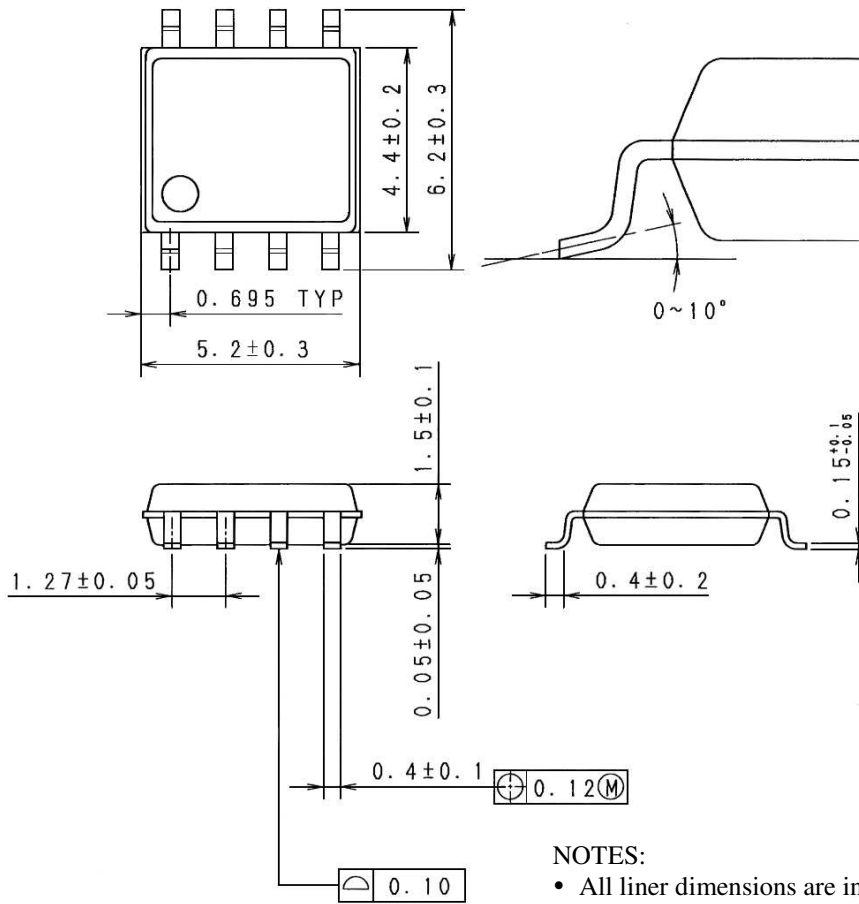

NOTES:

- All liner dimensions are in mm
- Pb-free. Device composition compliant with the RoHS directive

7. Marking Diagram

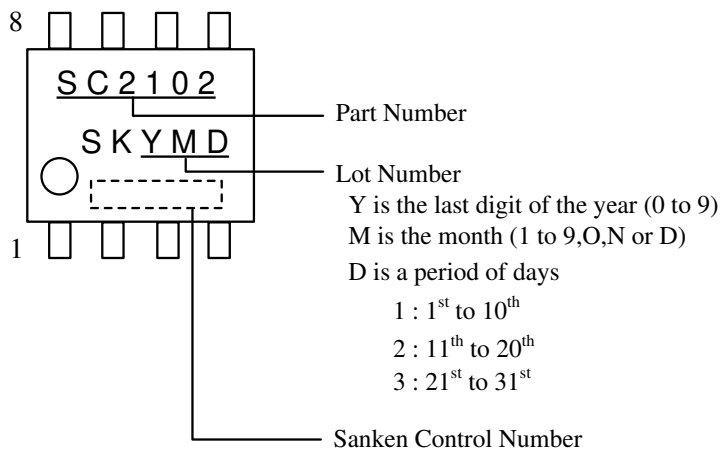

## 8. Operational Description

All of the parameter values used in these descriptions are typical values. With regard to current direction, "+" indicates sink current (toward the IC) and "-" indicates source current (from the IC).

### 8.1 Operational Description of Interleaved DCM

Figure 8-1 through Figure 8-4 show the PFC (Power Factor Correction) circuits and the operational waveforms of both single phase and two phase interleaved DCM (Discontinuous Conduction Mode).

Single phase DCM is well known as a technique that achieves low switching noises because the drain current increases from zero when a power MOSFET turns on, and is not steep shape waveforms as shown in Figure 8-2. However, the usable power level of the single phase DCM is limited by the very high input / output ripple currents.

The two phase interleaved DCM incorporates two boost converters, and is able to cancel the input ripple currents and to reduce the output ripple currents due to the phase difference of 180° between two converters as shown in Figure 8-3.

The interleaved DCM achieves a PFC system with lower switching noise and smaller input filter areas, compared with the single phase DCM. Because lower input / output ripple currents increase the filtering effect of EMI filters and reduce switching noises.

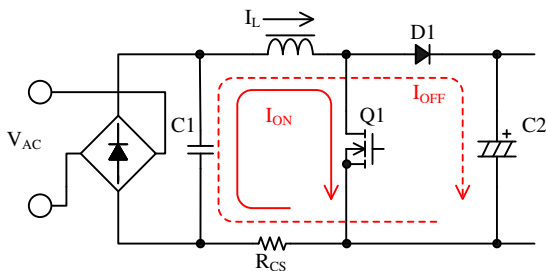

Figure 8-1 Single phase PFC circuit

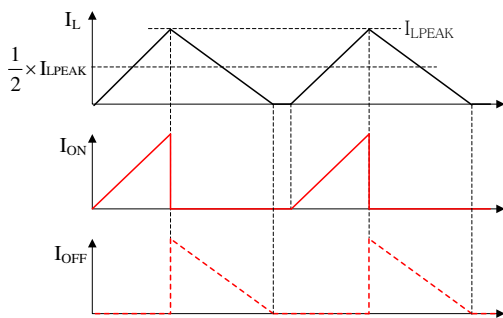

Figure 8-2 Operational waveform of single phase DCM

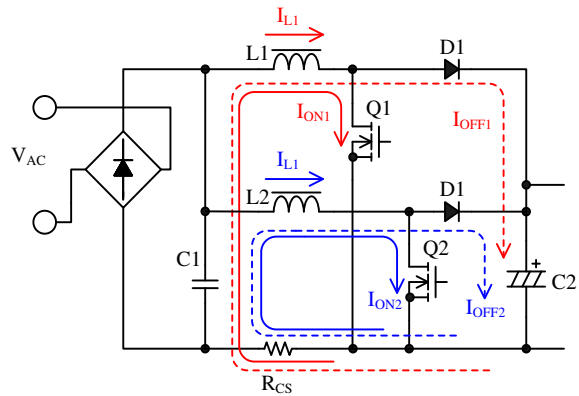

Figure 8-3 Two phase interleaved DCM PFC circuit

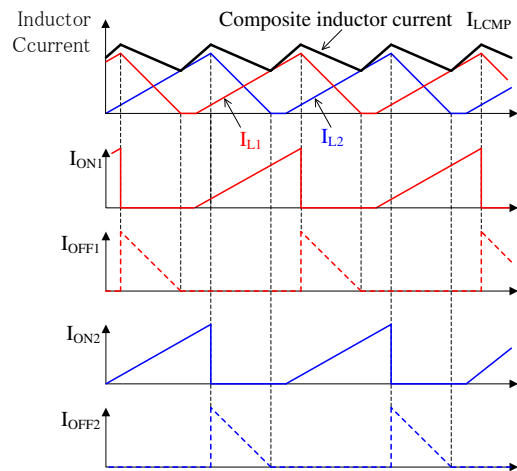

Figure 8-4 Operational waveform of two phase interleaved DCM

### 8.2 Startup Operation

The peripheral circuits around VCC pin and COMP pin is shown in Figure 8-5.

VCC pin is the external power supply for the IC. AC input voltage and the external voltage for VCC terminal are provided, and when following conditions are satisfied, the control circuit starts switching operation.

- FB pin voltage increases to more than  $V_{FB(OLDH)} = 0.70$  which is equivalent to about 20% of rated output voltage.
- VCC pin voltage increases to more than  $V_{CC(ON)} = 11.6$  V.

When VFB pin voltage decreases to  $V_{FB(OLDL)} = 0.50$  V or less, the control circuit stops switching operation and enters into the standby mode even if VCC pin voltage increases to  $V_{CC(ON)}$  or more.

Figure 8-6 shows the operational waveform at startup. At startup, COMP pin is charged by  $I_{COMP(SO)} = -30 \mu A$ , and thus the output power increases gradually until VFB

pin voltage becomes 3.2V (corresponds to about 90% of rated output voltage). This Soft-start Function reduces the stress on power devices.

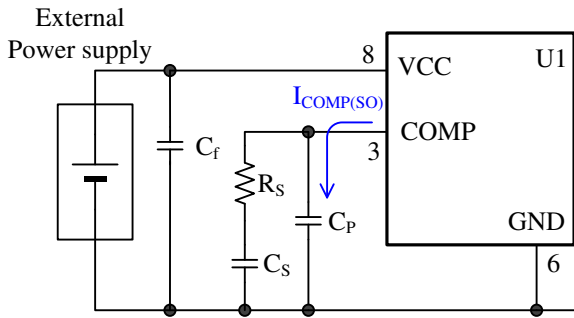

Figure 8-5 Peripheral circuit of VCC pin and COMP pin

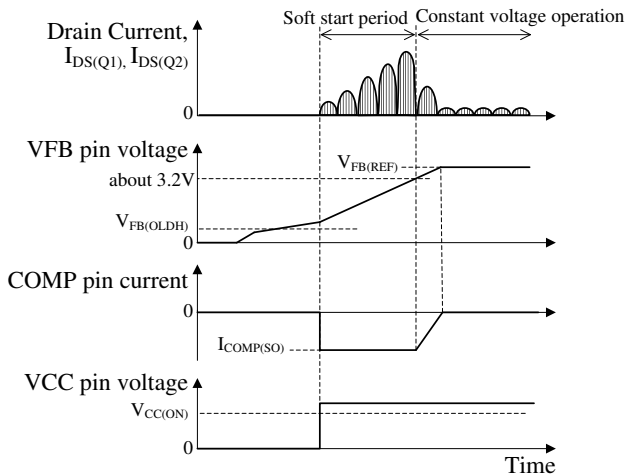

Figure 8-6 operational waveforms at startup

As shown in Figure 8-7, when VCC pin voltage decreases to  $V_{CC(OFF)} = 10.6\text{ V}$  or less, the control circuit stops switching operation by UVLO (Undervoltage lockout) circuit, and reverts to the standby mode before startup.

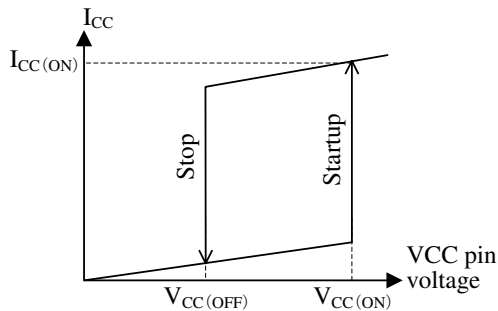

Figure 8-7 Relationship of VCC pin voltage and circuit current  $I_{CC}$

### 8.3 Voltage Control Operation

The PFC circuit with a general single phase DCM is shown in Figure 8-8. The L1 current is detected by auxiliary winding D and the off time of MOSFET is controlled.

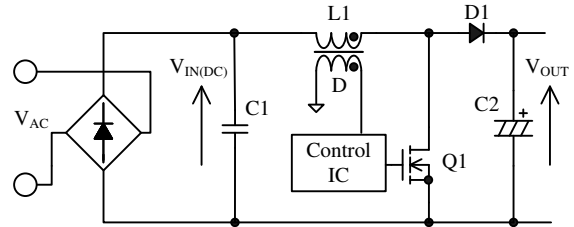

Figure 8-8 General current detection circuit of single phase PFC

In the boost PFC converter, the  $t_{ON}$  is a function of load power. In case of DCM,  $t_{OFF}$  is expressed as follows:

$$t_{OFF} > \frac{V_{IN(DC)}}{V_{OUT} - V_{IN(DC)}} \times t_{ON} \quad (8-1)$$

where,

$V_{IN(DC)}$ : C1 voltage

$V_{OUT}$ : Output voltage

$t_{ON}$ : On time of MOSFET

Since the IC does not require the D winding for current detection, simple PFC circuit is achieved. Figure 8-9 shows the peripheral circuit of VIN pin, VFB pin and COMP pin.

The IC makes both  $t_{ON}$  and  $t_{OFF}$  internally using VIN pin voltage, FB pin voltage and COMP pin voltage.

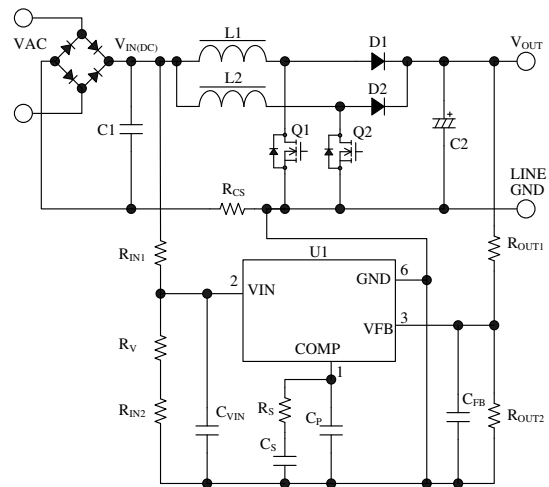

Figure 8-9 Peripheral circuit of VIN, VFB and COMP

$t_{ON}$  is proportional to COMP pin voltage which depends on the output voltage. The maximum on time  $t_{ONMAX} = 20.7 \mu s$  is specified by  $V_{IN} = 0.5 V$  and  $V_{COMP} = 4V$ .

The maximum on time depends on VIN pin voltage. Figure 8-10 shows the typical relationship between VIN pin voltage and the maximum on time  $t_{ONMAX(VIN)}$  ( $V_{COMP} = 4V$ ).

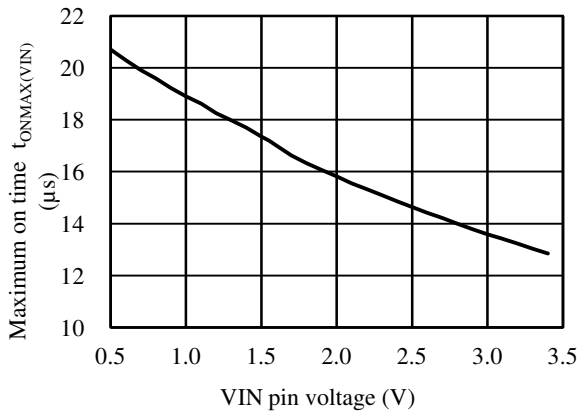

Figure 8-10 relation between VIN pin voltage and maximum on time ( $V_{COMP} = 4 V$ )

**VIN Pin and VFB Pin Parameter Design**

VIN pin detects input voltage and VFB pin detects output voltage. Since these voltages are used for internal calculation of off time, the voltage detection circuits should be well matched. Thus  $R_{IN1}$ ,  $R_{IN2}$ ,  $C_{VIN}$  values of the input portion should be equal to  $R_{OUT1}$ ,  $R_{OUT2}$ ,  $C_{FB}$  values of the output portion.  $R_{IN1}$  and  $R_{OUT1}$  are recommended the resistors in several hundreds  $k\Omega$  to several  $M\Omega$  range and anti-electromigration type, such as metal oxide film resistor. The variation in the value of  $R_{IN1}$ ,  $R_{IN2}$ ,  $R_{OUT1}$  and  $R_{OUT2}$  affect the accuracy of output voltage. Thus these resistors are recommended to be high accuracy type. As shown in Figure 8-9, resistor  $R_V$  is recommended to add for adjustment.  $C_{IN}$  and  $C_{FB}$  are for noise reduction. Capacitors of about 0.1 nF to 10 nF are recommended, if necessary.

Since the dividers of input portion and output portion are designed to be equal, Equation(8-1) can be expressed as Equation(8-2) using VIN pin voltage and VFB voltage.

$$t_{OFF} > \frac{V_{IN}}{V_{FB} - V_{IN}} \times t_{ON} \tag{8-2}$$

where,  
 $V_{IN}$ : VIN pin voltage  
 $V_{FB}$ : VFB pin voltage  
 $t_{ON}$ : On time of MOSFET

**COMP Pin Parameter Design (Error Amplifier Phase Compensation)**

COMP pin is the output of the internal error amplifier. The error amplifier system consists of a transconductance amplifier and switched current sources that implement the enhanced response functions. The phase compensation circuit is connected between COMP and GND COMP pins. This response is set below 20 Hz to maintain power factor correction at standard commercial power frequencies of 50 or 60 Hz.

In Figure 8-9, the phase compensation components,  $C_P$ ,  $C_S$  and  $R_S$ , are recommended as follows and may be adjusted to reduce ripple or to enhance transient load response at the output voltage.

- $C_P$ : 0.047  $\mu F$  to 0.47  $\mu F$
- $C_S$ : 0.47  $\mu F$  to 10  $\mu F$
- $R_S$ : 10  $k\Omega$  to 100  $k\Omega$

**8.4 High Speed Response Function (HSR)**

The boost PFC is input the sinusoidal waveform of AC input voltage with commercial frequency, and the voltage control has the characteristic of responding to low frequency. As a result, the dynamic load response becomes slow, and may cause the output voltage  $V_{OUT}$  to drop more easily.

High Speed Response Function (HSR) is built-in to reduce variation of the output voltage under dynamic load change conditions.

Figure 8-11 shows the operational waveform of HSR.

When VFB terminal voltage increases to  $V_{FB(HSR)EN} = 3.4 V$  or more, the control circuit enables HSR operation.

After this, when VFB terminal voltage decreases to  $V_{FB(HSR)AC} = 3.2 V$  or less due to dynamic load change conditions or others, the control circuit starts HSR operation. During this operation, COMP terminal is charged by  $I_{COMP(SO)HSR} = -100 \mu A$  and the output power increases until VFB pin voltage increases to 3.2 V.  $V_{FB(HSR)AC} = 3.2 V$  is equivalent to about 91.4% of the rated output voltage,  $V_{OUT}$ .

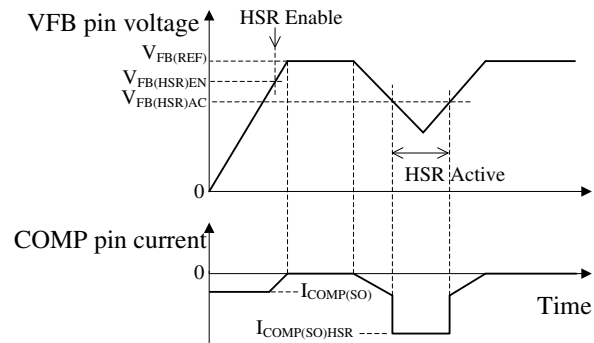

Figure 8-11 Operational waveform of HSR

### 8.5 Gate Drive

OUT1 pin and OUT2 pin are the gate drive pins for driving the external MOSFET directly. The specification is listed in Table 8-1.

Table 8-1 Current and Voltage specifications of OUT1pin and OUT2 pin

Parameter	Symbol	Rating
OUT1, OUT2 Pin Voltage (Low)	$V_{OUT(L)}$	0.3 V(max.)
OUT1, OUT2 Pin Voltage (High)	$V_{OUT(H)}$	10.2 V
OUT1, OUT2 Pin Peak Source Current	$I_{OUT(SO)}$	- 0.5 A
OUT1, OUT2 Pin Peak Sink Current	$I_{OUT(SI)}$	0.5 A

Figure 8-12 shows the peripheral circuit of OUT1 and OUT2.

Resistors, R1, R2, R3 and R4 in Figure 8-12 should be adjusted for actual operation because these values relate to the board layout patterns and power MOSFET capacitances.

The gate resistors R1 and R3 are recommended in several to several tens of  $\Omega$  range, and should be adjusted to reduce gate voltage ringing and EMI noise.

R2 and R4 help to prevent malfunctions caused by steep dV/dt during power MOSFET turns off. The recommended values are in the 10k to 100k $\Omega$  range, and should be placed close to power MOSFET's gate and source terminals.

Power MOSFET should be selected so that these  $V_{GS(th)}$  threshold voltages are less than  $V_{OUT(H)}$  enough over entire operating temperature range.

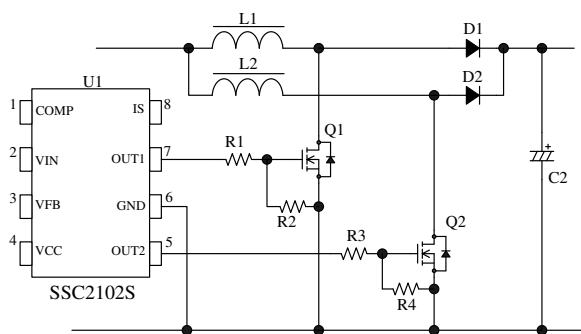

Figure 8-12 Peripheral circuit of OUT1 pin and OUT2 pin

### 8.6 Overcurrent Protection (OCP)

Figure 8-13 shows IS pin peripheral circuit. The Overcurrent Protection (OCP) detects the inductor current of both L1 and L2 by using current detection resistor  $R_{CS}$ . The voltage of both ends of  $R_{CS}$  is induced into IS pin

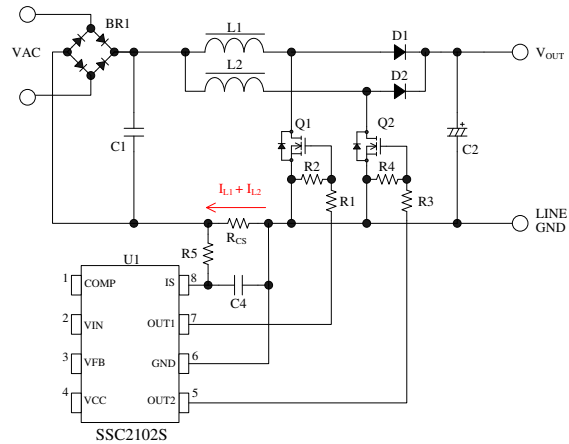

Figure 8-13 Peripheral circuit of IS pin

There are two threshold voltages,  $V_{IS(OCPL)}$  and  $V_{IS(OCPH)}$  in OCP operation. The details are as follows.

• **IS Pin Overcurrent Protection Threshold Voltage (Low):  $V_{IS(OCPL)}$**

When the inductor current increases and IS terminal voltage decreases to  $V_{IS(OCPL)} = -0.42$  V, control circuit turns off the external power MOSFET. The control is different depending on the state of  $V_{OUT1}$  and  $V_{OUT2}$ .

1) When either  $V_{OUT1}$  or  $V_{OUT2}$  is High, the output, which is set High, is set to Low as shown in Figure 8-14.

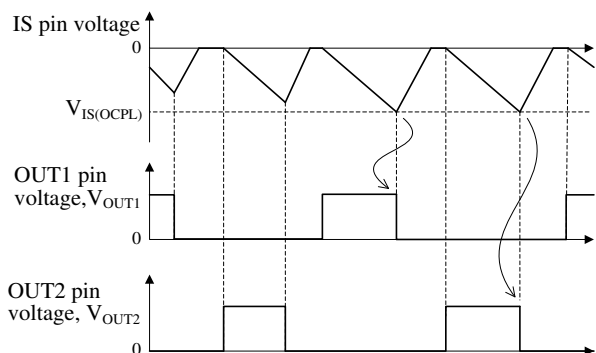

Figure 8-14 OCP operation by  $V_{IS(OCPL)}$  (either  $V_{OUT1}$  or  $V_{OUT2}$  is high)

2) When both  $V_{OUT1}$  and  $V_{OUT2}$  are High, the output which is set to High ahead is set to Low as shown in Figure 8-15.

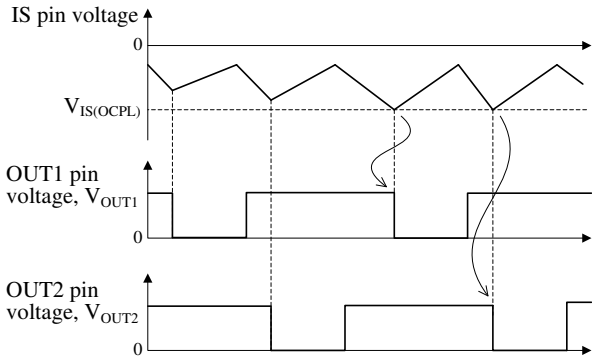

Figure 8-15 OCP operation by  $V_{IS(OCPL)}$  (Both  $V_{OUT1}$  and  $V_{OUT2}$  are High)

• **IS Pin Overcurrent Protection Threshold Voltage (High):  $V_{IS(OCPH)}$**

This protection operates on such abnormal conditions as the inductor is shorted or is saturated. When the inductor current of L1 and L2 increases abnormally and IS terminal voltage decreases to  $V_{IS(OCPH)} = -0.55$  V or less, the control circuit sets both  $V_{OUT1}$  and  $V_{OUT2}$  to Low on pulse-by-pulse basis as shown in Figure 8-16.

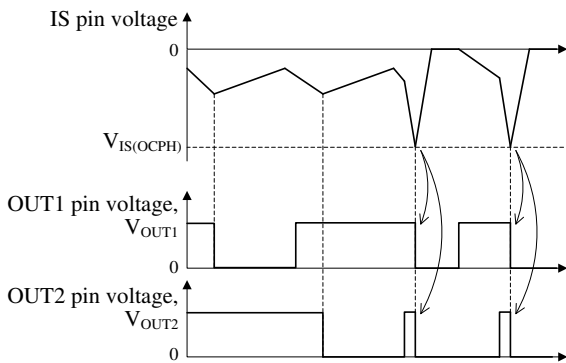

Figure 8-16 OCP operation by  $V_{IS(OCPH)}$

**8.7 Overvoltage Protection (OVP)**

Figure 8-17 shows VFB pin peripheral circuit and Figure 8-18 shows the operational waveforms of Overvoltage Protection (OVP).

The output overvoltage is detected by using VFB pin. There are two threshold voltages,  $V_{FB(SOVP)}$  for Soft Overvoltage Protection (SOVP) and  $V_{FB(OVP)}$  for OVP. The operations are shown below.

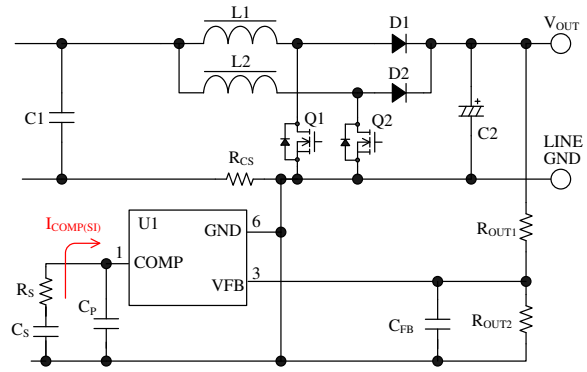

Figure 8-17 VFB pin peripheral circuit

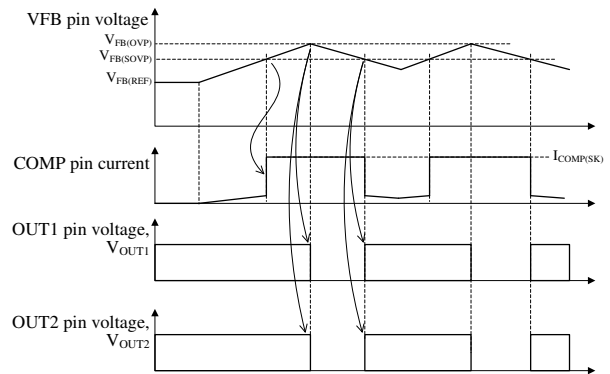

Figure 8-18 Operational waveform of OVP

• **Soft Overvoltage Protection (SOVP)**

When VFB pin voltage increases to  $V_{FB(SOVP)} = 3.68$  V, Soft Overvoltage Protection (SOVP) is activated. Thus, COMP pin is discharged by  $I_{COMP(SI)} = 100 \mu A$  and the output voltage is decreased.

$V_{FB(SOVP)}$  is equivalent to about 105% of the rated output voltage. The output voltage, which operates SOVP, is calculated approximately as follows.

$$V_{OUT(SOVP)} = \frac{V_{OUT}}{V_{FB(REF)}} \times V_{FB(SOVP)} \quad (V) \quad (8-3)$$

where,

$V_{OUT}$  : Output voltage in normal operation

$V_{FB(REF)}$  : Error AMP reference voltage, 3.5 V

• **Overvoltage Protection (OVP)**

When VFB pin voltage increases to  $V_{FB(OVP)} = 3.72$  V, Overvoltage Protection (OVP) is activated. And thus both OUT1 and OUT2 are set to Low. When VFB pin voltage decreases to  $V_{FB(SOVP)}$ , the control circuit deactivate both OVP and SOVP, and reverts to switching operation.  $V_{FB(OVP)}$  is equivalent to about 106 % of the rated output voltage. The output voltage, which operates OVP, is calculated approximately as follows.

$$V_{OUT(OVP)} = \frac{V_{OUT}}{V_{FB(REF)}} \times V_{FB(OVP)} \quad (V) \quad (8-4)$$

where,

$V_{OUT}$  : Output voltage in normal operation

$V_{FB(REF)}$  : Error AMP reference voltage, 3.5 V

### 8.8 Open Loop Detection (OLD)

Figure 8-19 shows VFB pin peripheral circuit.

The Open Loop Detection (OLD) is activated when the output voltage detection resistor  $R_{OUT1}$  is open.

In case the  $R_{OUT1}$  becomes open in normal operation, VFB pin voltage starts to decrease. When VFB pin voltage decreases to  $V_{FB(OLDL)} = 0.50$  V, the IC stops switching operation.

When VFB pin voltage increases to  $V_{FB(OLDH)} = 0.70$  V or more, the control circuit starts switching operation.  $V_{FB(OLDH)}$  is equivalent to about 20% of the rated output voltage.

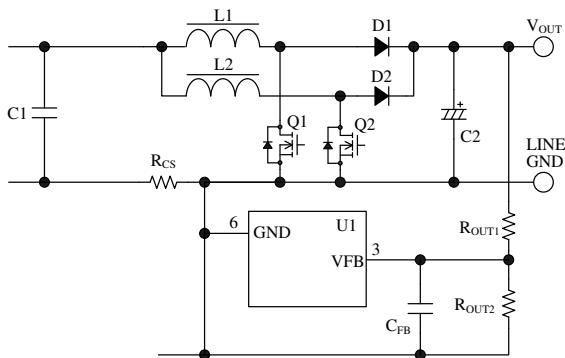

Figure 8-19 VFB pin peripheral circuit

### 8.9 Open Pin Protection (OPP)

VFB, IS and VIN pins have Open Pin Protection (OPP) internally.

These pins are internally connected with pull-up current sources. In case the pins are open, each pin voltage is pulled up to each internal supply voltage. The protection operations are as follows.

- VFB pin Open: VFB pin voltage increases and the Overvoltage Protection (OVP) is activated. Thus, both OUT1 and OUT2 are set to Low.
- IS pin Open: IS pin voltage increases and Overcurrent Protection (OCP) is activated. Thus, both OUT1 and OUT2 are set to Low.
- VIN pin Open: VIN pin voltage increases and the control circuit limits its operation, or stops.

### 8.10 Input Undervoltage Protection (UVP)

Input voltage is detected by VIN pin. When input voltage decreases due to the instantaneous power interruption etc., Input Undervoltage Protection (UVP) is activated. Figure 8-20 shows the operational waveforms.

When input voltage decrease and the VIN pin voltage decreases to  $V_{IN(P)} = 0.3$  V or more for the internal setting delay time,  $t_{VIN} = 14$  ms or more, the High Speed Response Function (HSR) (refer to Section 8.4) is disabled, the capacitor connected to COMP pin is discharged by  $I_{COMP(SI)}$  and COMP pin voltage is nearly zero.

After instantaneous power failure, input voltage increases and VIN pin voltage increase to  $V_{IN(P)}$  or more, output power is increased slowly by Soft-start Function (refer to Section 8.2) in order to reduce the stress on power devices.

Since the over current is inhibited by UVP at return from instantaneous power failure, output voltage can increase again smoothly.

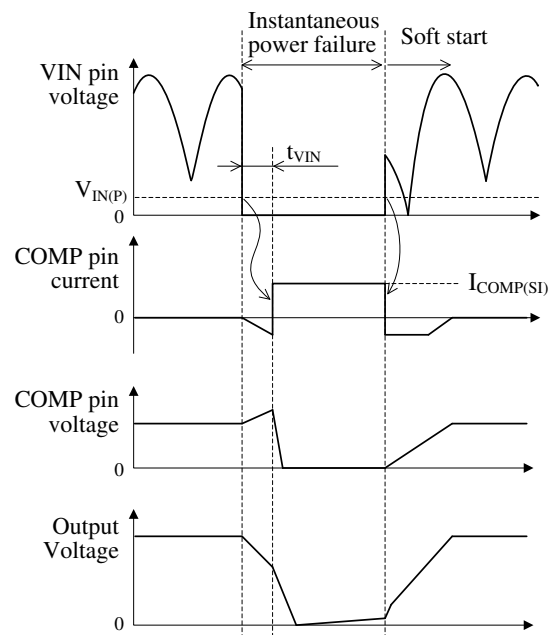

Figure 8-20 the instantaneous power failure operation waveform

### 8.11 Thermal Shutdown (TSD)

When the temperature of the IC increases to  $T_{JTSDH} = 150$  °C (min.) or more, the control circuit stops switching operation. Conversely, when that decreases to  $T_{JTSDL} = 140$  °C (min.) or less, the control circuit starts switching operation.



## 9. Parameters Design

- Symbols in this section are defined as follows.
  - $P_O$ : PFC Output power per phase (W)
  - $\eta$ : PFC Efficiency
  - $t_{ON}$ : On time (s)
  - $V_{INRMS(MIN)}$ : Minimum input RMS voltage (V)
  - $V_{INRMS(MAX)}$ : Maximum input RMS voltage (V)
  - $V_{OUT}$ : PFC output voltage (V)
  - $I_{INRMS}$ : Input RMS current (A)
- The symbols of components are defined as shown in Figure 9-1.

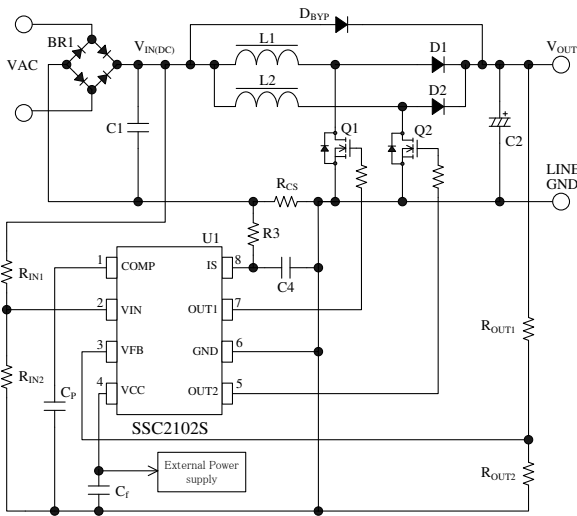

Figure 9-1 IC peripheral circuit

### 9.1 Inductor Design

Inductor is designed as follows.

#### (1) Setting of Output Voltage, $V_{OUT}$

At first, output voltage of PFC should be set. Input voltage must always be lower than output voltage in a boost converter. Generally, output voltage,  $V_{OUT}$ , is set to at least 10 V higher than the peak voltage of the maximum commercial AC input voltage.

$$V_{OUT} \geq \sqrt{2} \times V_{INRMS(MAX)} + 10 \quad (V) \quad (9-1)$$

#### (2) Calculation of Maximum Inductor Peak Current (per phase)

The waveform of the inductor current is triangular. The maximum peak current,  $I_{LPEAK(MAX)}$ , running through each inductor is calculated as follows.

#### • Calculation of Maximum Input Power

Maximum input power,  $P_{IN(MAX)}$  is calculated as follows.

$$P_{IN(MAX)} = \frac{K_{OM} \times K_{LM} \times P_O}{\eta} \quad (W) \quad (9-2)$$

Where,

$K_{OM}$ : Coefficient of the output power margin

$K_{LM}$ : Coefficient of the inductor saturation margin

$\eta$ : PFC Efficiency

The values of  $K_{OM}$  and  $K_{LM}$  are generally in the range of 1.2 to 1.3.  $\eta$  depends on the ON-resistance,  $R_{DS(ON)}$ , of the power MOSFET and the forward voltage,  $V_F$  of the rectifier diode.  $\eta$  is generally in the range of 0.90 to 0.97.

#### • Calculation of Maximum Inductor Peak Current

Maximum inductor peak current,  $I_{LPEAK(MAX)}$  is calculated using the above results and Equation (9-3).

$$I_{LPEAK(MAX)} = \frac{2\sqrt{2} \times P_{IN(MAX)}}{V_{INRMS(MIN)}} \quad (A) \quad (9-3)$$

#### (3) Calculation of Maximum On Time

The IC makes both on time and off time internally using  $V_{IN}$  pin voltage,  $V_{FB}$  pin voltage and  $V_{COMP}$  pin voltage. Maximum on time is calculated as follows.

#### • Calculation of $V_{IN}$ pin voltage, $V_{IN}$

Defining the  $V_{IN}$  pin voltage as  $V_{IN}$  and the voltage of C2 as  $V_{IN(DC)}$ , The relationship between  $V_{IN(DC)}$  and input detection resistors,  $R_{IN1}$  and  $R_{IN2}$  is as follows.

$$\frac{R_{IN1} + R_{IN2}}{R_{IN2}} = \frac{V_{IN(DC)}}{V_{IN}} \quad (9-4)$$

The relationship between output voltage,  $V_{OUT}$  and output detection resistors,  $R_{OUT1}$  and  $R_{OUT2}$  is as follows.

$$\frac{R_{OUT1} + R_{OUT2}}{R_{OUT2}} = \frac{V_{OUT}}{V_{FB(REF)}} \quad (9-5)$$

The values of  $R_{IN1}$  and  $R_{IN2}$  should be equal to the values of  $R_{OUT1}$  and  $R_{OUT2}$ .

From Equation (9-4) and Equation (9-5),  $V_{IN}$  is calculated as follows.

$$\begin{aligned} \frac{V_{IN(DC)}}{V_{IN}} &= \frac{V_{OUT}}{V_{FB(REF)}} \\ \Rightarrow V_{IN} &= \frac{V_{IN(DC)} \times V_{FB(REF)}}{V_{OUT}} \quad (V) \end{aligned}$$

In case of minimum AC input voltage, on time becomes maximum.  $V_{IN}$  at maximum on time is calculated as follows.

$$V_{IN} = \frac{\sqrt{2} \times V_{INRMS(MIN)} \times V_{FB(REF)}}{V_{OUT}} \quad (V) \quad (9-6)$$

• Maximum on time

Maximum on time depends on VIN pin voltage as shown in Figure 8-10 (Section 8.2). Maximum on time can be gotten from result of Esuation (9-6) and Figure 8-10.

(4) Calculation of Inductance value for a single phase.

The maximum inductance for a single phase,  $L_{MAX}$  is calculated as follows using the results of (2) and (3).

$$L_{MAX} = \frac{\sqrt{2} \times V_{INRMS(MIN)} \times t_{ONMAX(VIN)}}{I_{LPEAK(MAX)}} \quad (H) \quad (9-7)$$

(5) Calculation of Inductor Turns

The turns number of inductor, N is calculated as follows using the results of (2) and (4).

$$N = \frac{I_{LPEAK(MAX)} \times L_{MAX}}{Ae \times \Delta B_{MAX}} \quad (\text{turns}) \quad (9-8)$$

where,

$Ae$  : the effective area of inductor core ( $m^2$ )

$\Delta B_{MAX}$  : maximum magnetic flux density (T)

< Inductor Design Example >

Inductor design examle is shown below. The specifications of power suply are as follows.

$$V_{INRMS(MIN)} = 85V$$

$$V_{INRMS(MAX)} = 265V$$

$$P_O = 150 \text{ W for each phase}$$

(Total output power of two phase Interleaved PFC = 300 W)

(1) Setting of Output Voltage,  $V_{OUT}$

$$\begin{aligned} V_{OUT} &\geq \sqrt{2} \times V_{INRMS(MAX)} + 10 \\ &\geq \sqrt{2} \times 265 + 10 \approx 385(V) \end{aligned}$$

hence,  $V_{OUT}$  is set to 390 V(DC)

(2) Calculation of  $I_{LPEAK(MAX)}$

In case  $K_{OM} = 1.2$ ,  $K_{LM} = 1.2$ ,  $\eta = 0.92$  and  $V_{INRMS(MIN)} = 85 \text{ V}$ , the maximum input power for a single phase is calculated as follows.

$$\begin{aligned} P_{IN(MAX)} &= \frac{K_{OM} \times K_{LM} \times P_O}{\eta} \\ &= \frac{1.2 \times 1.2 \times 150}{0.92} \approx 235(W) \end{aligned}$$

Then the maximum peak inductor current for a single phase is calculated as follows.

$$\begin{aligned} I_{LPEAK(MAX)} &= \frac{2\sqrt{2} \times P_{IN(MAX)}}{V_{INRMS(MIN)}} \\ &= \frac{2\sqrt{2} \times 235}{85} \approx 7.8(A) \end{aligned}$$

(3) Calculation of  $t_{ONMAX(VIN)}$

Using  $V_{FB(REF)} = 3.5 \text{ V(typ.)}$  and the result of (1),  $V_{IN}$  is calculated as follows.

$$\begin{aligned} V_{IN} &= \frac{\sqrt{2} \times V_{INRMS(MIN)} \times V_{FB(REF)}}{V_{OUT}} \\ &= \frac{\sqrt{2} \times 85 \times 3.5}{390} = 1.08(V) \end{aligned}$$

The relation in Figure 8-10 shows  $t_{ONMAX(VIN)}$  at  $V_{IN} = 1.08 \text{ V}$  is about 18.6  $\mu s$ .

(4) Using the results of (2) and (3)

$$\begin{aligned} L_{MAX} &= \frac{\sqrt{2} \times V_{INRMS(MIN)} \times t_{ONMAX(VIN)}}{I_{LPEAK(MAX)}} \\ &= \frac{\sqrt{2} \times 85 \times 18.6 \times 10^{-6}}{7.8} \\ &\approx 286 \times 10^{-6} (H) \end{aligned}$$

(5) When  $Ae$  is 102  $mm^2$  and  $\Delta B_{MAX}$  is 250 mT, N is calculated as follows using the results of (2) and (4).

$$\begin{aligned} N &= \frac{I_{LPEAK(MAX)} \times L_{MAX}}{Ae \times \Delta B_{MAX}} \\ &= \frac{7.8 \times 286 \times 10^{-6}}{102 \times 10^{-6} \times 0.25} \\ &\approx 87(\text{turns}) \end{aligned}$$

## 9.2 Overcurrent Detection Resistor, R<sub>CS</sub>

Overcurrent detection resistor, R<sub>CS</sub>, detects the composite inductor current of both converters.

As the peak value of composite inductor current varies by ON-duty D<sub>ON(MAX)</sub>, the coefficient defined as K<sub>R</sub> is calculated from its D<sub>ON(MAX)</sub> and R<sub>CS</sub> is calculated by I<sub>LCMP</sub>.

### (1) Calculation of Maximum ON-duty D<sub>ON(MAX)</sub>

D<sub>ON(MAX)</sub> is calculated as follows using V<sub>OUT</sub> derived in Section 9.1 (1).

$$D_{ON(MAX)} = \frac{V_{OUT} - \sqrt{2} \times V_{INRMS(MIN)}}{V_{OUT}} \quad (9-9)$$

### (2) Calculation of Inductor Current Coefficient, K<sub>R</sub>

From the result of (1),

- When D<sub>ON(MAX)</sub> ≥ 0.5

$$K_R = 1 + \frac{D_{ON(MAX)} - 0.5}{D_{ON(MAX)}} \quad (9-10)$$

- When D<sub>ON(MAX)</sub> < 0.5

$$K_R = 1 + \frac{0.5 - D_{ON(MAX)}}{1 - D_{ON(MAX)}} \quad (9-11)$$

### (3) Calculation of Composite Inductor Current, I<sub>LCMP(MAX)</sub>

Using the result of (2), I<sub>LCMP(MAX)</sub> is calculated as follows.

$$I_{LCMP(MAX)} = K_R \times \frac{2\sqrt{2} \times K_{OM} \times P_O}{\eta \times V_{INRMS(MIN)}} \quad (A) \quad (9-12)$$

where,

K<sub>OM</sub> : Output power margin coefficient

P<sub>O</sub> : Output power for a single phase (W)

η : PFC efficiency

Generally, K<sub>OM</sub> is the range of 1.2 to 1.3. η depends on the ON-resistance, R<sub>DS(ON)</sub>, of the power MOSFET and the forward voltage, V<sub>F</sub> of the rectifier diode. η is generally in the range of 0.90 to 0.97.

### (4) Calculation of Over Current Detection Resistor, R<sub>CS</sub>

Using the result of (3), R<sub>CS</sub> is calculated as follows.

$$R_{CS} = \frac{|V_{IS(OCPL)}|}{I_{LCMP(MAX)}} \quad (\Omega) \quad (9-13)$$

where,

V<sub>IS(OCPL)</sub> : IS Pin Overcurrent Protection Threshold Voltage (Low) is -0.42 V(typ.)

### <R<sub>CS</sub> Design Example>

R<sub>CS</sub> design example is shown below. The specifications of power supply are as follows.

V<sub>INRMS(MIN)</sub> = 85V

V<sub>INRMS(MAX)</sub> = 265V

P<sub>O</sub> = 150 W for each phase

(Total output power of two phase Interleaved PFC = 300 W)

Output Voltage: V<sub>OUT</sub> = 390 V

#### (1) Calculation of D<sub>ON(MAX)</sub>

$$\begin{aligned} D_{ON(MAX)} &= \frac{V_{OUT} - \sqrt{2} \times V_{INRMS(MIN)}}{V_{OUT}} \\ &= \frac{390 - \sqrt{2} \times 85}{390} \approx 0.69 \end{aligned}$$

#### (2) Calculation of K<sub>R</sub>

Using the the result of (1) and Equation (9-10), K<sub>R</sub> is calculated as follows.

$$\begin{aligned} K_R &= 1 + \frac{D_{ON(MAX)} - 0.5}{D_{ON(MAX)}} \\ &= 1 + \frac{0.69 - 0.5}{0.69} \approx 1.28 \end{aligned}$$

#### (3) Calculation of I<sub>LCMP(MAX)</sub>

$$\begin{aligned} I_{LCMP(MAX)} &= K_R \times \frac{2\sqrt{2} \times K_{OM} \times P_O}{\eta \times V_{INRMS(MIN)}} \\ &= 1.28 \times \frac{2\sqrt{2} \times 1.2 \times 150}{0.92 \times 85} \approx 8.3(A) \end{aligned}$$

#### (4) Calculation of R<sub>CS</sub>

Using the result of (3), R<sub>CS</sub> is calculated as follows.

$$\begin{aligned} R_{CS} &= \frac{|V_{IS(OCPL)}|}{I_{LCMP(MAX)}} \\ &= \frac{|-0.42|}{8.3} \approx 0.05(\Omega) \end{aligned}$$

## 10. Design Notes

### 10.1 External Components

Take care to use properly rated, including derating as necessary and proper type of components. Figure 10-1 shows the IC peripheral circuit.

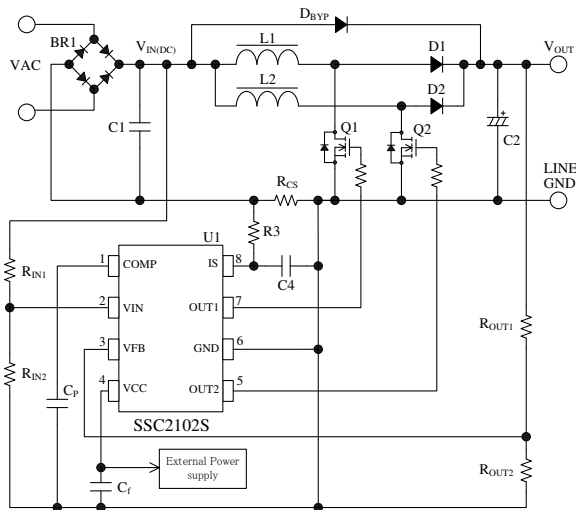

Figure 10-1 The IC peripheral circuit.

- **High Resistance and High Voltage Applied Resistor,  $R_{IN1}$  and  $R_{OUT1}$**   
Since  $R_{IN1}$  and  $R_{OUT1}$  have applied high voltage and have high resistance value,  $R_{IN1}$  and  $R_{OUT1}$  should be selected from resistors designed against electromigration or use a combination of resistors for that.
- **Current Detection Resistor,  $R_{CS}$**   
 $R_{CS}$  is the resistor for the current detection. A high frequency switching current flows to  $R_{CS}$ , and may cause poor operation if a high inductance resistor is used. Choose a low inductance and high surge-tolerant type.
- **Boost Diode,  $D1$  and  $D2$**   
Choose a boost diode having proper margin of a peak reverse voltage  $V_{RSM}$  against output voltage  $V_{OUT}$ . A fast recovery diode is recommended to reduce the switching noise and loss. Please ask our staff about our lineup. The size of heat sink is chosen taking into account some loss by  $V_F$  and recovery current of boost diode.
- **Bypass Diode,  $D_{BYP}$**   
Bypass diode protects the boost diode from a large current such as an inrush current. A high surge current tolerance diode is recommended. Please ask our staff about our lineup.

- **Output Electrolytic Capacitor,  $C2$**

Apply proper derating to ripple current, voltage, and temperature rise. Use of high ripple current and low impedance types, designed for switch mode power supplies, is recommended.

- **Inductor,  $L1$  and  $L2$**

Apply proper design margin to temperature rise by core loss and copper loss.

### 10.2 PCB Trace Layout and Component Placement

Since the PCB circuit trace design and the component layout significantly affects operation, EMI noise, and power dissipation, the high frequency PCB trace should be low impedance with small loop and wide trace.

In addition, the ground traces affect radiated EMI noise, and wide, short traces should be taken into account.

Figure 10-2 shows the circuit design example.

- (1) **Main Circuit Trace Layout**

This is the main trace containing switching currents, and thus it should be as wide trace and small loop as possible.

- (2) **Control Ground Trace Layout**

Since the operation of IC may be affected from the large current of the main trace that flows in control ground trace, the control ground trace should be separated from main trace and connected at a single point grounding of point A in Figure 10-2 as close to the  $R_{CS}$  pin as possible.

- (3)  **$R_{CS}$  Trace Layout**

$R_{CS}$  should be placed as close as possible to the Source pin and the IS pin. The peripheral components of IS pin should be connected by dedicated pattern from root of  $R_{CS}$ . The connection between the power ground of the main trace and the IC ground should be at a single point ground (point A in Figure 10-2) which is close to the base of  $R_{CS}$ .

- (4) **Peripheral Component of IC**

The components for control connected to the IC should be placed as close as possible to the IC, and should be connected as short as possible to the each pin.

- (5) **Gate Resistor ( $R2$  and  $R4$ ) Trace Layout**

Gate resistor should be connected as short as possible to the Source pin and Gate pin of each MOSFET.

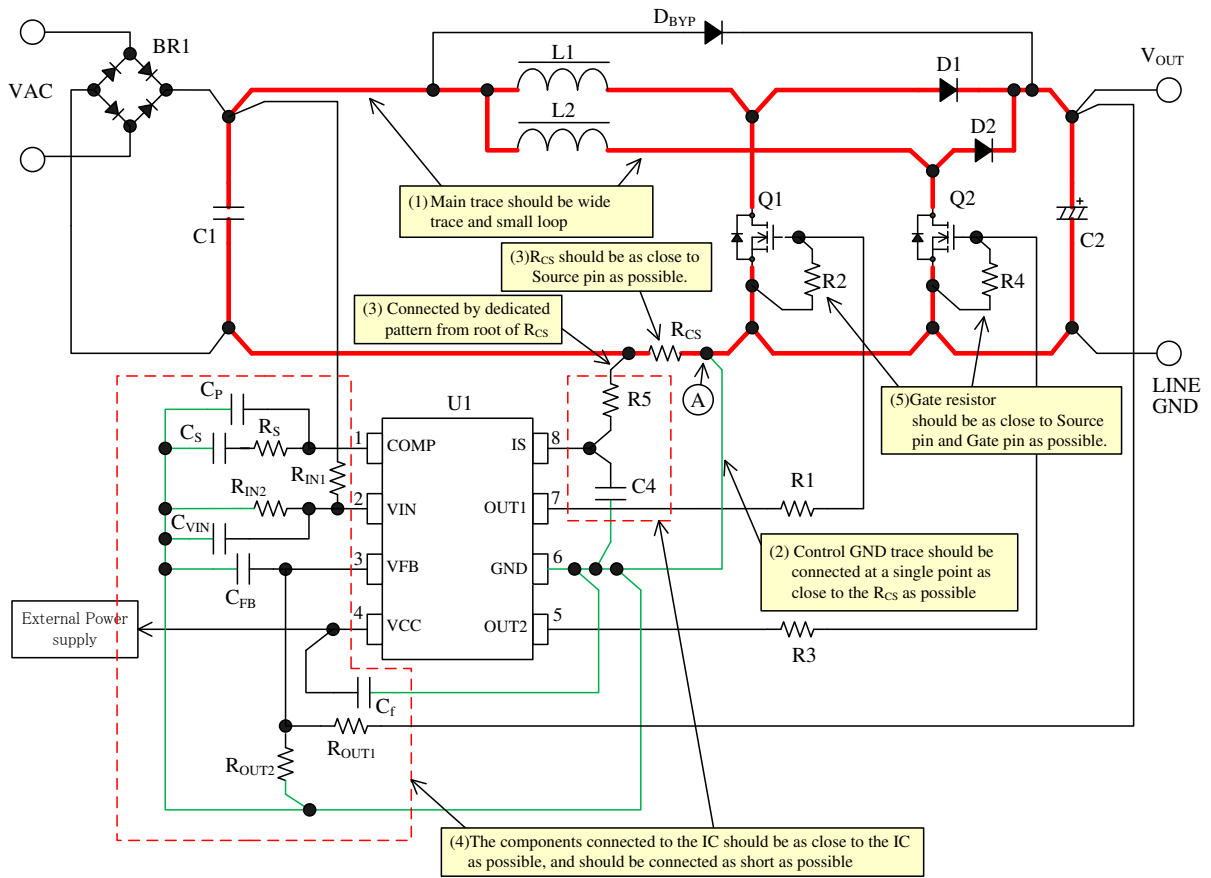

Figure 10-2 Example of connection of peripheral component

## OPERATING PRECAUTIONS

In the case that you use Sanken products or design your products by using Sanken products, the reliability largely depends on the degree of derating to be made to the rated values. Derating may be interpreted as a case that an operation range is set by derating the load from each rated value or surge voltage or noise is considered for derating in order to assure or improve the reliability. In general, derating factors include electric stresses such as electric voltage, electric current, electric power etc., environmental stresses such as ambient temperature, humidity etc. and thermal stress caused due to self-heating of semiconductor products. For these stresses, instantaneous values, maximum values and minimum values must be taken into consideration. In addition, it should be noted that since power devices or IC's including power devices have large self-heating value, the degree of derating of junction temperature affects the reliability significantly.

Because reliability can be affected adversely by improper storage environments and handling methods, please observe the following cautions.

### Cautions for Storage

- Ensure that storage conditions comply with the standard temperature (5 to 35°C) and the standard relative humidity (around 40 to 75%); avoid storage locations that experience extreme changes in temperature or humidity.
- Avoid locations where dust or harmful gases are present and avoid direct sunlight.
- Reinspect for rust on leads and solderability of the products that have been stored for a long time.

### Cautions for Testing and Handling

When tests are carried out during inspection testing and other standard test periods, protect the products from power surges from the testing device, shorts between the product pins, and wrong connections. Ensure all test parameters are within the ratings specified by Sanken for the products.

### Soldering

- When soldering the products, please be sure to minimize the working time, within the following limits:
  - 260 ± 5 °C 10 ± 1 s (Flow, 2 times)
  - 380 ± 10 °C 3.5 ± 0.5 s (Soldering iron, 1 time)

### Electrostatic Discharge

- When handling the products, the operator must be grounded. Grounded wrist straps worn should have at least 1MΩ of resistance from the operator to ground to prevent shock hazard, and it should be placed near the operator.
- Workbenches where the products are handled should be grounded and be provided with conductive table and floor mats.
- When using measuring equipment such as a curve tracer, the equipment should be grounded.
- When soldering the products, the head of soldering irons or the solder bath must be grounded in order to prevent leak voltages generated by them from being applied to the products.
- The products should always be stored and transported in Sanken shipping containers or conductive containers, or be wrapped in aluminum foil.

**IMPORTANT NOTES**

- The contents in this document are subject to changes, for improvement and other purposes, without notice. Make sure that this is the latest revision of the document before use.
- Application examples, operation examples and recommended examples described in this document are quoted for the sole purpose of reference for the use of the products herein and Sanken can assume no responsibility for any infringement of industrial property rights, intellectual property rights, life, body, property or any other rights of Sanken or any third party which may result from its use.
- Unless otherwise agreed in writing by Sanken, Sanken makes no warranties of any kind, whether express or implied, as to the products, including product merchantability, and fitness for a particular purpose and special environment, and the information, including its accuracy, usefulness, and reliability, included in this document.
- Although Sanken undertakes to enhance the quality and reliability of its products, the occurrence of failure and defect of semiconductor products at a certain rate is inevitable. Users of Sanken products are requested to take, at their own risk, preventative measures including safety design of the equipment or systems against any possible injury, death, fires or damages to the society due to device failure or malfunction.
- Sanken products listed in this document are designed and intended for the use as components in general purpose electronic equipment or apparatus (home appliances, office equipment, telecommunication equipment, measuring equipment, etc.).  
When considering the use of Sanken products in the applications where higher reliability is required (transportation equipment and its control systems, traffic signal control systems or equipment, fire/crime alarm systems, various safety devices, etc.), and whenever long life expectancy is required even in general purpose electronic equipment or apparatus, please contact your nearest Sanken sales representative to discuss, prior to the use of the products herein.  
The use of Sanken products without the written consent of Sanken in the applications where extremely high reliability is required (aerospace equipment, nuclear power control systems, life support systems, etc.) is strictly prohibited.
- When using the products specified herein by either (i) combining other products or materials therewith or (ii) physically, chemically or otherwise processing or treating the products, please duly consider all possible risks that may result from all such uses in advance and proceed therewith at your own responsibility.
- Anti radioactive ray design is not considered for the products listed herein.
- Sanken assumes no responsibility for any troubles, such as dropping products caused during transportation out of Sanken's distribution network.
- The contents in this document must not be transcribed or copied without Sanken's written consent.