



Chipsmall Limited consists of a professional team with an average of over 10 year of expertise in the distribution of electronic components. Based in Hongkong, we have already established firm and mutual-benefit business relationships with customers from,Europe,America and south Asia,supplying obsolete and hard-to-find components to meet their specific needs.

With the principle of "Quality Parts,Customers Priority,Honest Operation,and Considerate Service",our business mainly focus on the distribution of electronic components. Line cards we deal with include Microchip,ALPS,ROHM,Xilinx,Pulse,ON,Everlight and Freescale. Main products comprise IC,Modules,Potentiometer,IC Socket,Relay,Connector.Our parts cover such applications as commercial,industrial, and automotives areas.

We are looking forward to setting up business relationship with you and hope to provide you with the best service and solution. Let us make a better world for our industry!



## Contact us

Tel: +86-755-8981 8866 Fax: +86-755-8427 6832

Email & Skype: info@chipsmall.com Web: www.chipsmall.com

Address: A1208, Overseas Decoration Building, #122 Zhenhua RD., Futian, Shenzhen, China



UNCONTROLLED DOCUMENT

|                   |                                     |      |
|-------------------|-------------------------------------|------|
| PART NUMBER       |                                     | REV. |
| SSF-LXH2100GD(-1) |                                     |      |
| REV.              | E.C.N. NUMBER AND REVISION COMMENTS | DATE |

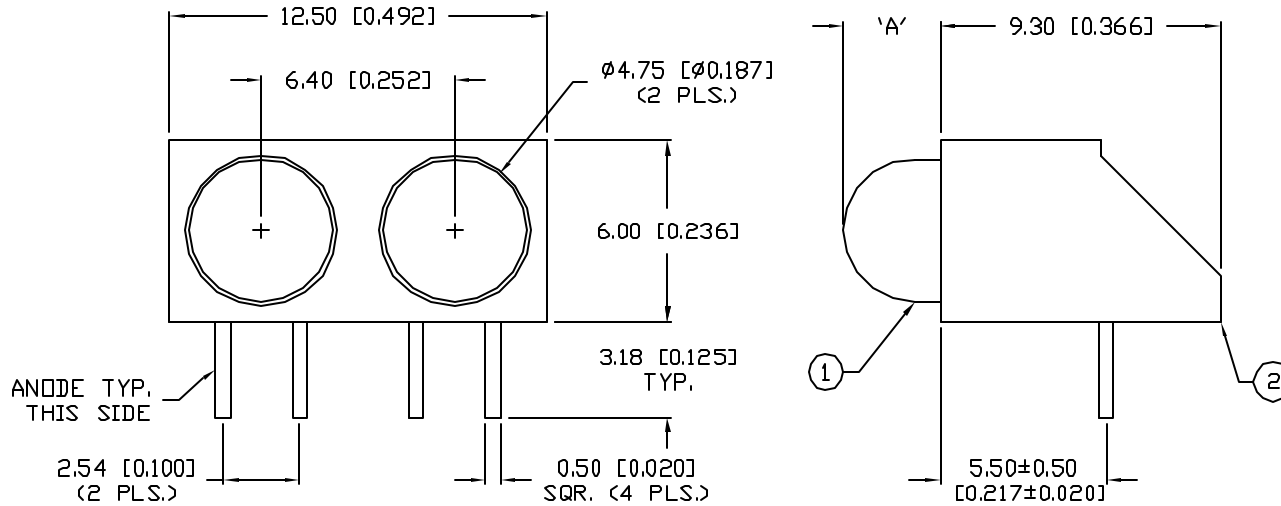

DIM 'A'  
 NO P/N SUFFIX: 3.2 [0.126]  
 WITH -1 SUFFIX: 4.7 [0.187]

NOTES:

- NO P/N SUFFIX, SSL-LX507F3GD, GREEN LED. (2 PCS.)  
 WITH -1 SUFFIX, SSL-LX509F3GD, GREEN LED. (2 PCS.)
- SSH-LXH2100, BLACK HOLDER.

ELECTRO-OPTICAL CHARACTERISTICS  $T_A=25^\circ\text{C}$   $I_f=20\text{mA}$

| PARAMETER          | MIN            | TYP | MAX | UNITS    | TEST COND            |
|--------------------|----------------|-----|-----|----------|----------------------|
| PEAK WAVELENGTH    |                | 565 |     | nm       |                      |
| FORWARD VOLTAGE    |                | 2.2 | 2.6 | $V_f$    |                      |
| REVERSE VOLTAGE    | 5.0            |     |     | $V_r$    | $I_f=100\mu\text{A}$ |
| AXIAL INTENSITY    |                | 30  |     | mcd      | $I_f=20\text{mA}$    |
| VIEWING ANGLE      |                | 80  |     | 2x theta |                      |
| EMITTED COLOR:     | GREEN          |     |     |          |                      |
| EPOXY LENS FINISH: | GREEN DIFFUSED |     |     |          |                      |

LIMITS OF SAFE OPERATION AT 25°C

| PARAMETER                | MAX        | UNITS      |
|--------------------------|------------|------------|
| PEAK FORWARD CURRENT*    | 150        | mA         |
| STEADY CURRENT           | 25         | mA         |
| POWER DISSIPATION        | 105        | mW         |
| DERATE FROM 25°C         | -1.2       | mW/°C      |
| OPERATING, STORAGE TEMP. | -40 TO +85 | °C         |
| SOLDERING TEMP.          | +260       | °C         |
| 2.0mm FROM BODY          |            | 3 SEC. MAX |

\*  $t < 10\mu\text{s}$

UNCONTROLLED DOCUMENT

\*UNLESS OTHERWISE SPECIFIED TOLERANCE IS  $\pm 0.25\text{mm}$  ( $\pm 0.010''$ )

|      |                   |
|------|-------------------|
| REV. | PART NUMBER       |
|      | SSF-LXH2100GD(-1) |

**CONFIDENTIAL INFORMATION**  
 THE INFORMATION CONTAINED IN THIS DOCUMENT IS THE PROPERTY OF LUMEX INC. EXCEPT AS SPECIFICALLY AUTHORIZED IN WRITING BY LUMEX INC., THE HOLDER OF THIS DOCUMENT SHALL KEEP ALL INFORMATION CONTAINED HEREIN CONFIDENTIAL AND SHALL PROTECT SAME IN WHOLE OR IN PART FROM DISCLOSURE AND DISSEMINATION TO ALL THIRD PARTIES.

**LUMEX INCORPORATED**  
 290 E. HELLEN ROAD  
 PALATINE, ILLINOIS 60067  
 PHONE: 1-847-359-2790  
 WEB: HTTP://WWW.LUMEX.COM

T-5mm (T-1 3/4) DUAL LED HOLDER,  
 TWO 565nm GREEN LEDS, GREEN DIFFUSED LENS.

**RELIABILITY NOTE**  
 OUR MANY YEARS OF EXPERIENCE DATA ACCUMULATION INDICATE THAT SOLDER HEAT IS A MAJOR CAUSE OF EARLY AND FUTURE FAILURE. PLEASE PAY ATTENTION TO YOUR SOLDERING PROCESS.

|           |             |              |               |
|-----------|-------------|--------------|---------------|
| DRAWN BY: | CHECKED BY: | APPROVED BY: | DATE: 9-15-99 |
| BC        |             |              | PAGE: 1 OF 1  |
|           |             |              | SCALE: N/A    |