



Chipsmall Limited consists of a professional team with an average of over 10 year of expertise in the distribution of electronic components. Based in Hongkong, we have already established firm and mutual-benefit business relationships with customers from,Europe,America and south Asia,supplying obsolete and hard-to-find components to meet their specific needs.

With the principle of “Quality Parts,Customers Priority,Honest Operation,and Considerate Service”,our business mainly focus on the distribution of electronic components. Line cards we deal with include Microchip,ALPS,ROHM,Xilinx,Pulse,ON,Everlight and Freescale. Main products comprise IC,Modules,Potentiometer,IC Socket,Relay,Connector.Our parts cover such applications as commercial,industrial, and automotives areas.

We are looking forward to setting up business relationship with you and hope to provide you with the best service and solution. Let us make a better world for our industry!



Contact us

Tel: +86-755-8981 8866 Fax: +86-755-8427 6832

Email & Skype: info@chipsmall.com Web: www.chipsmall.com

Address: A1208, Overseas Decoration Building, #122 Zhenhua RD., Futian, Shenzhen, China



QuasarBrite™ IP67 Panel Mount LED Indicator



ITW ECS brand Lumex® announces the release of the QuasarBrite™ IP67 Panel Mount LED Indicator with IP67 class front panel protection, AC/DC compatible with ranges from 6V to 220V.

Features:	Benefits:
IP67 rating	Front panel IP67 rating protects panels from excessing dust and moisture exposure in indoor and outdoor applications
PCB or wire panel mount	Wire to panel design choices available as well as board to panel allow for more design in opportunities
Choice of brushing materials and illumination options	Wide range of choice available to customer, to tailor to their applications. Red, green, yellow, blue, orange, white LED options, and brass, stainless steel, and black nickel finishes for added aesthetics in application
Bezels accommodate panels 1.5mm - 10mm thick	Customer able to design panel to their own specifications, eliminating the need for backward design
15-20mA current consumption	Long LED life in application

QuasarBrite™ IP67 Panel Mount LED Indicator

Technical Information & Drawing

PN	Emitted Color	Lens Type	Terminal Type	Voltage Range
SSI-LXW06DNS-I	Red	Flat	Solder Slug	6V
SSI-LXW06DNS-I12V	Red	Flat	Solder Slug	6V
SSI-LXW06DNS-G	Green	Flat	Solder Slug	6V
SSI-LXW06DNS-G12V	Green	Flat	Solder Slug	6V
SSI-LXW06DNS-Y	Yellow	Flat	Solder Slug	6V
SSI-LXW06DNS-Y12V	Yellow	Flat	Solder Slug	6V
SSI-LXW08DNS-I	Red	Domed	Screw Terminal	12V
SSI-LXW08DNS-I12V	Red	Domed	Screw Terminal	12V

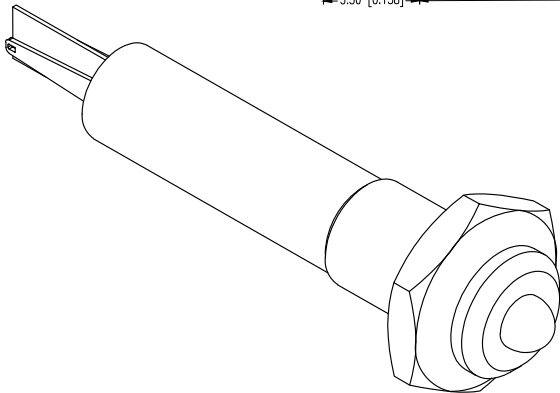
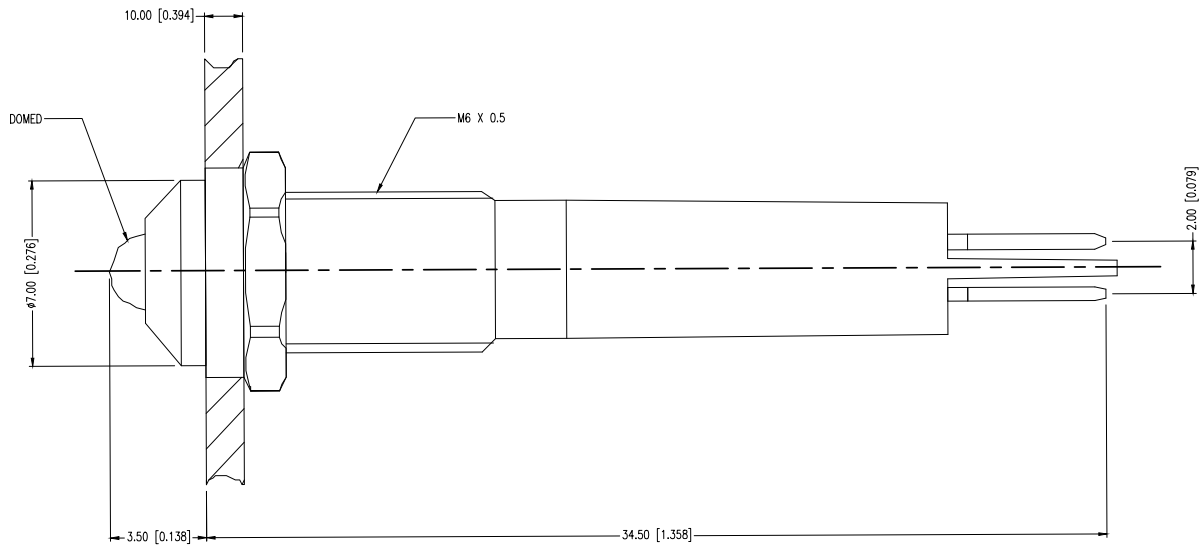

SPECIFICATIONS:

- LED CURRENT: 20MA @ 2V~36V DC, 2MA @ 110V~220V AC
- DIELECTRIC STRENGTH: 2,000V RMS 50~60HZ
- OPERATING TEMPERATURE: -40°C ~ +85°C
- IP CLASS: IP67 FRONT PANEL PROTECTION
- TORQUE: 0.1NM MAX APPLIED TO NUT
- BI POLAR LED

CIRCUIT DIAGRAM:

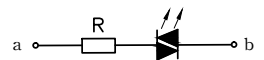

QuasarBrite™ IP67 Panel Mount LED Indicator

The QuasarBrite™ IP67 Panel Mount LED Indicator serves in a wide variety of markets and applications. Custom options available.

Markets:	Applications:
Medical	Dental/surgical indicators
Transportation	ATV dashboard indicators, marine switches
Industrial Controls	Outdoor robotic equipment

