



Chipsmall Limited consists of a professional team with an average of over 10 year of expertise in the distribution of electronic components. Based in Hongkong, we have already established firm and mutual-benefit business relationships with customers from,Europe,America and south Asia,supplying obsolete and hard-to-find components to meet their specific needs.

With the principle of "Quality Parts,Customers Priority,Honest Operation,and Considerate Service",our business mainly focus on the distribution of electronic components. Line cards we deal with include Microchip,ALPS,ROHM,Xilinx,Pulse,ON,Everlight and Freescale. Main products comprise IC,Modules,Potentiometer,IC Socket,Relay,Connector.Our parts cover such applications as commercial,industrial, and automotives areas.

We are looking forward to setting up business relationship with you and hope to provide you with the best service and solution. Let us make a better world for our industry!



Contact us

Tel: +86-755-8981 8866 Fax: +86-755-8427 6832

Email & Skype: info@chipsmall.com Web: www.chipsmall.com

Address: A1208, Overseas Decoration Building, #122 Zhenhua RD., Futian, Shenzhen, China



SSL152x

SMPS ICs for mains LED drivers

Rev. 02 — 10 March 2009

Product data sheet

1. General description

The SSL152x family is a Switched Mode Power Supply (SMPS) controller IC that operates directly from the rectified universal mains. It is implemented in the high-voltage EZ-HV SOI process, combined with a low-voltage BiCMOS process. The device includes a high-voltage power switch and a circuit for start-up directly from the rectified mains voltage.

A dedicated circuit for valley switching is built in, which makes a very efficient slim-line electronic concept for solid state lighting applications possible.

The SSL152x can operate in applications with a power range of up to 15 W. For a power range between 15 W and 25 W the SSL1623PH is the best choice. For LED powers above 25 W the SSL1750 can be used.

In its most basic applications, the SSL152x family acts as a voltage source. Here, no additional secondary electronics are required. A combined voltage and current source can be realized with minimum costs for external components. Implementation of the SSL152x family renders an efficient and low cost power supply system for mains LED drivers.

2. Features

- Designed for mains LED drivers up to 15 W
- Integrated power switch:
 - ◆ SSL1522T: 12 Ω ; 650 V
 - ◆ SSL1523P: 6.5 Ω ; 650 V
- Operates from universal AC mains supplies (80 V to 276 V)
- Adjustable frequency for flexible design
- RC oscillator for load insensitive regulation loop constant
- Valley switching for minimum switch-on loss
- Low standby power (< 100 mW) with frequency reduction at low power outputs
- Adjustable overcurrent protection
- Undervoltage protection
- Temperature protection
- Short circuit winding protection
- Simple application with both primary and secondary (opto) feedback
- Available in DIP8 and SO14 packages

3. Applications

- Retro fit LED lamps
- LED ballasts
- Contour lighting
- Channel letter lighting
- Commercial lighting, e.g. cabinet or freezer lights
- Other lighting applications

4. Quick reference data

Table 1. Quick reference data

Symbol	Parameter	Conditions	Min	Typ	Max	Unit
V _{DRAIN}	voltage on pin DRAIN	DMOS power transistor; T _j > 0 °C	-0.4	-	+650	V
R _{DSon}	drain-source on-state resistance	SSL1522T; I _{source} = -0.25 A				
		T _j = 25 °C	-	12	13.8	Ω
		T _j = 100 °C	-	17	19.6	Ω
		SSL1523P; I _{source} = -0.50 A				
		T _j = 25 °C	-	6.5	7.5	Ω
		T _j = 100 °C	-	9.0	10.0	Ω
V _{CC}	supply voltage	continuous	-0.4	-	+40	V
f _{osc}	oscillator frequency		10	100	200	kHz
I _{DRAIN}	current on pin DRAIN	V _{DRAIN} > 60 V				
		no auxiliary supply	-	1.5	2	mA
		with auxiliary supply	-	30	125	μA
T _{amb}	ambient temperature		-40	-	+85	°C

5. Ordering information

Table 2. Ordering information

Type number	Package		Version
	Name	Description	
SSL1523P	DIP8	plastic dual in-line package; 8 leads (300 mil)	SOT97-1
SSL1522T	SO14	plastic small outline package; 14-leads; body width 3.9 mm	SOT108-1

6. Block diagram

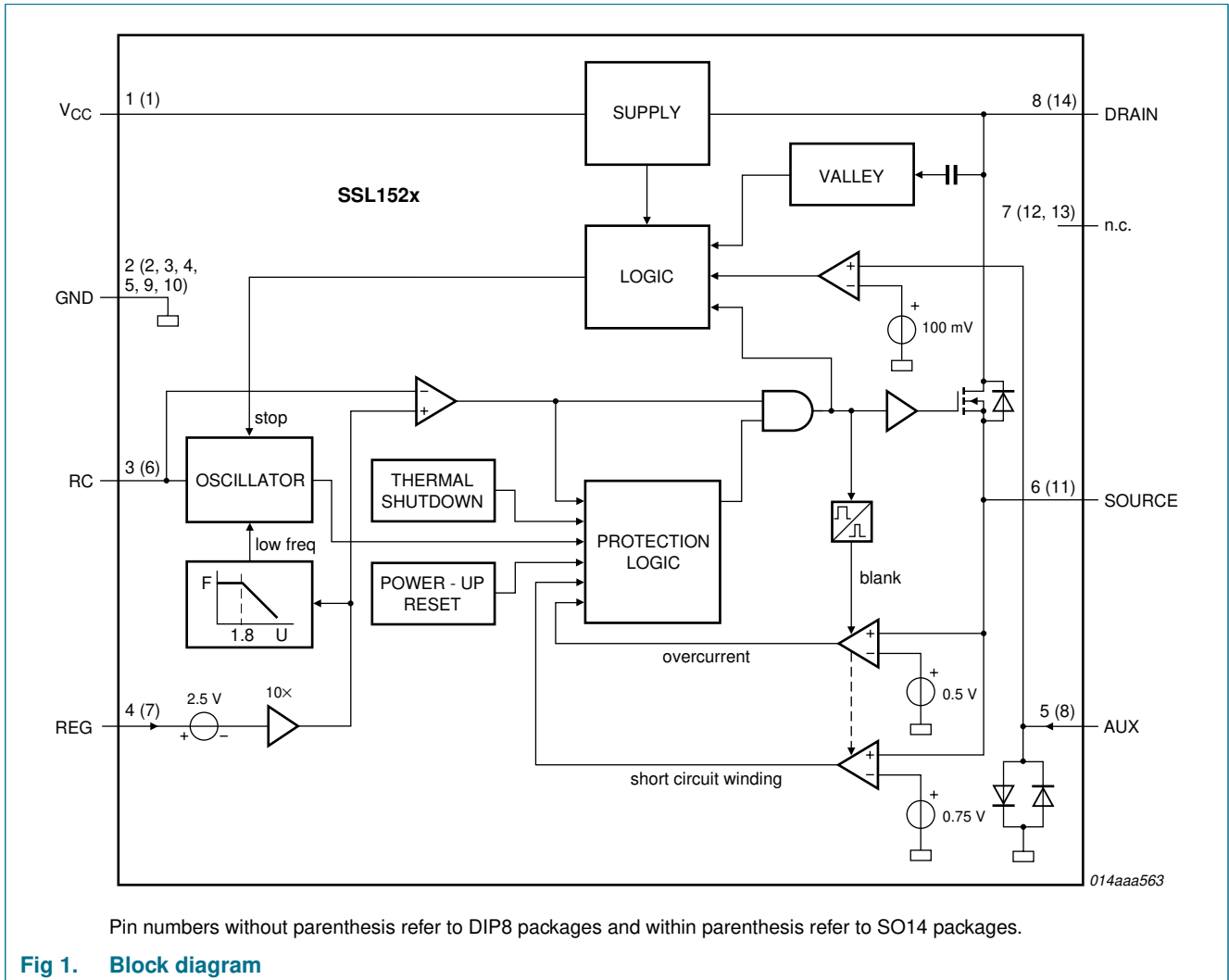

7. Pinning information

7.1 Pinning

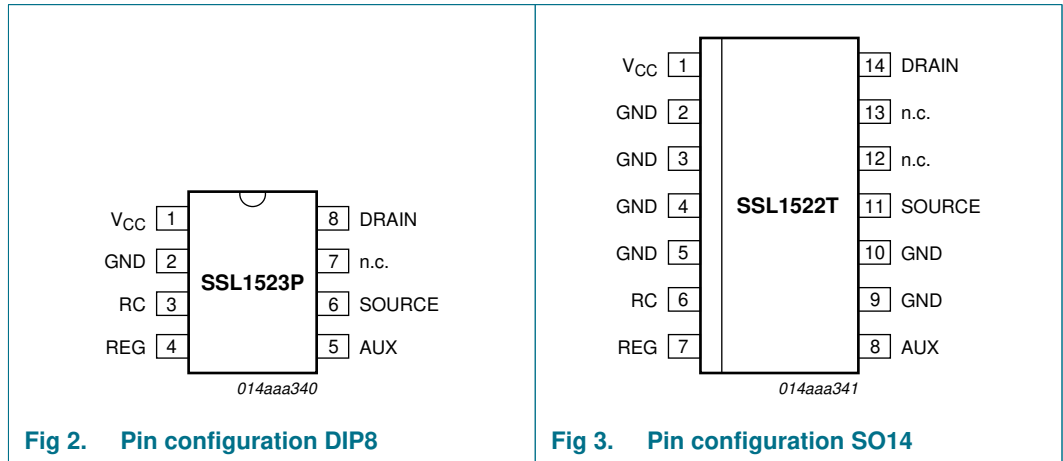

7.2 Pin description

Table 3. Pin description

Symbol	Pin		Description
	DIP8	SO14	
V _{CC}	1	1	supply voltage
GND	2	2	ground
GND	-	3	ground
GND	-	4	ground
GND	-	5	ground
RC	3	6	frequency setting
REG	4	7	regulation input
AUX	5	8	input for voltage from auxiliary winding for timing (demagnetization)
GND	-	9	ground
GND	-	10	ground
SOURCE	6	11	source of internal MOS switch
n.c.	7	12	not connected
n.c.	-	13	not connected
DRAIN	8	14	drain of internal MOS switch; input for start-up current and valley sensing

8. Functional description

The SSL152x family is the heart of a compact flyback converter, with the IC placed at the primary side. The auxiliary winding of the transformer can be used for indirect feedback to control the isolated output. This additional winding also powers the IC. A more accurate control of the output voltage and/or current can be implemented with an additional secondary sensing circuit and opto coupler feedback.

The SSL152x family uses voltage mode control. The switching frequency is determined by the maximum transformer demagnetizing time and the frequency of the oscillator. In the first case, the converter operates in the Self Oscillating Power Supply (SOPS) mode. In the latter case, it operates at a constant frequency, which can be adjusted with external components R_{RC} and C_{RC} . Furthermore, a primary stroke is started only in a valley of the secondary ringing. This can use constant power or constant current mode to drive LEDs. The valley switching principle minimizes capacitive switch-on losses.

8.1 Start-up and undervoltage lockout

Initially, the IC is self-supplying from the rectified mains voltage. The IC starts switching as soon as the voltage on pin V_{CC} passes the $V_{CC(\text{startup})}$ level. The supply is taken over by the auxiliary winding of the transformer as soon as V_{CC} is high enough and the supply from the line is stopped for high efficiency operation.

When for some reason the auxiliary supply is not sufficient, the high-voltage supply also supplies the IC. As soon as the voltage on pin V_{CC} drops below the $V_{CC(\text{stop})}$ level, the IC stops switching and restarts from the rectified mains voltage.

8.2 Oscillator

The frequency of the oscillator is set by the external resistor and capacitor on pin RC. The external capacitor is charged rapidly to the $V_{RC(\text{max})}$ level and, starting from a new primary stroke, it discharges to the $V_{RC(\text{min})}$ level. Because the discharge is exponential, the relative sensitivity of the duty factor to the regulation voltage at low duty factor is almost equal to the sensitivity at high duty factors. This results in a more constant gain over the duty factor range compared to systems with a linear sawtooth oscillator. Stable operation at low duty factors is easily realized. For high efficiency, the frequency is reduced as soon as the duty factor drops below its low power threshold. This is accomplished by increasing the oscillator charge time.

To ensure that the capacitor can be charged within the charge time, the value of the oscillator capacitor should be limited to approximately 1 nF.

8.3 Duty factor control

The duty factor is controlled by the internal regulation voltage and the oscillator signal on pin RC. The internal regulation voltage is equal to the external regulation voltage (minus 2.5 V) multiplied by the gain of the error amplifier (typically 20 dB).

8.4 Valley switching

A new cycle is started when the primary switch is switched on (see Figure 4). After a certain time (determined by the oscillator voltage RC and the internal regulation level), the switch is turned off and the secondary stroke starts. The internal regulation level is determined by the voltage on pin REG.

After the secondary stroke, the drain voltage shows an oscillation with a frequency of approximately:

$$\frac{1}{2 \times \pi \times \sqrt{(L_p \times C_p)}} \tag{1}$$

where:

L_p = primary self-inductance

C_p = parasitic capacitance on drain node

As soon as the oscillator voltage becomes high again and after the secondary stroke has ended, the circuit waits for a low drain voltage before starting a new primary stroke.

Figure 4 shows the drain voltage together with the valley signal, the signal indicating the secondary stroke and the RC voltage.

The primary stroke starts some time before the actual valley at low ringing frequencies, and some time after the actual valley at high ringing frequencies.

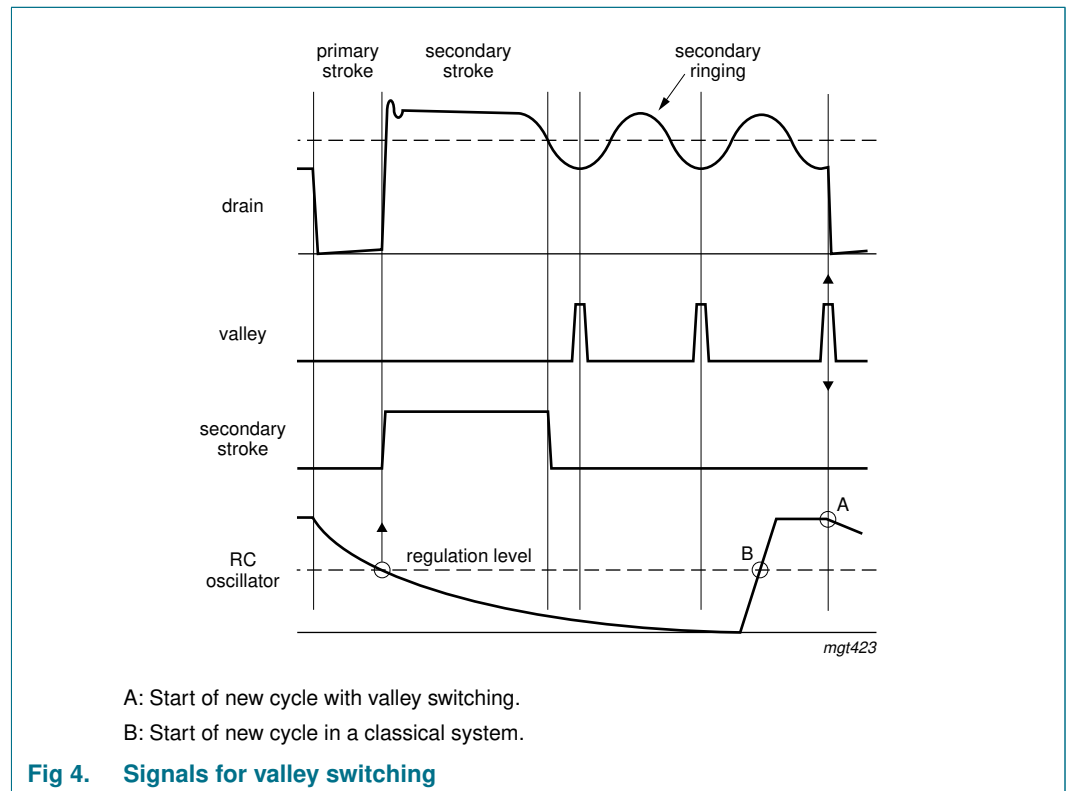

Figure 5 shows a typical curve for a reflected output voltage $N \times V_o$ of 80 V. This voltage is the output voltage V_o (see Figure 6) transferred to the primary side of the transformer with the factor N (determined by the turns ratio of the transformer). Figure 5 shows that the system switches at the minimum drain voltage for ringing frequencies of 480 kHz, thus reducing the switch-on losses to a minimum. At 200 kHz, the next primary stroke is started at 33° before the valley. The switch-on losses are still reduced significantly.

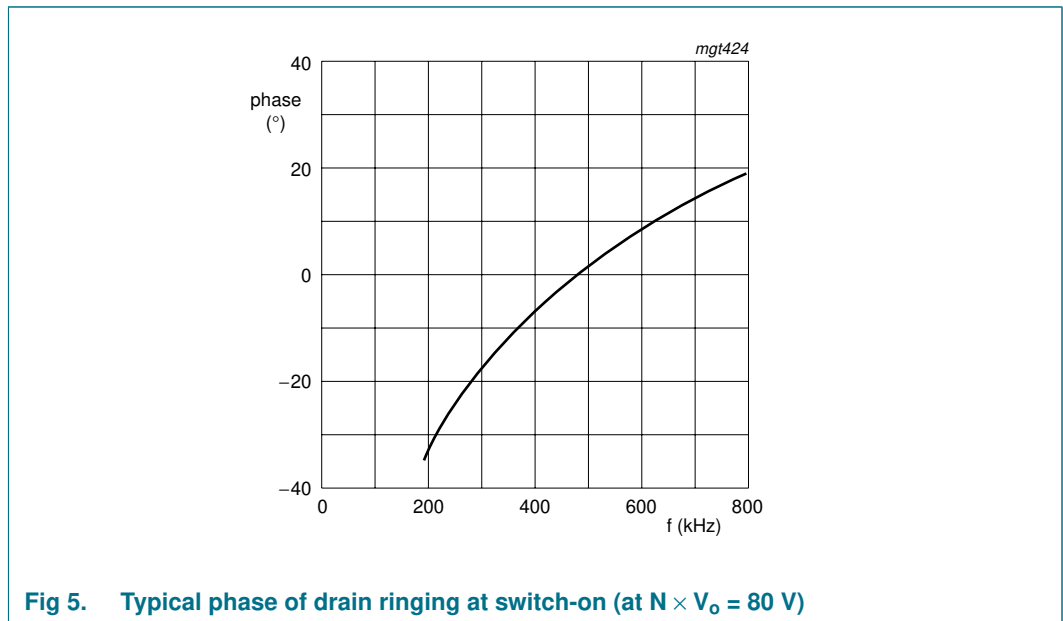

Fig 5. Typical phase of drain ringing at switch-on (at $N \times V_o = 80$ V)

8.5 Demagnetization

The system operates in discontinuous conduction mode all the time. As long as the secondary stroke has not ended, the oscillator will not start a new primary stroke. During the first $t_{sup(xfmr_ring)}$ seconds, demagnetization recognition is suppressed. This suppression may be necessary in applications where the transformer has a large leakage inductance and at low output voltages.

8.6 Minimum and maximum duty factor

The minimum duty factor of the switched mode power supply is 0 %. The maximum duty factor is set to 75 % (typical value at 100 kHz oscillation frequency).

8.7 OverCurrent Protection (OCP)

The cycle-by-cycle peak drain current limit circuit uses the external source resistor R_1 to measure the current. The circuit is activated after the leading edge blanking time t_{leb} . The protection circuit limits the source voltage to $V_{SOURCE(max)}$ and thus limits the primary peak current.

8.8 Short circuit winding protection

The short circuit winding protection circuit is also activated after the leading edge blanking time. If the source voltage exceeds the short circuit winding protection voltage V_{swp} , the IC stops switching. Only a power-on reset will restart normal operation. The short circuit winding protection also protects in case of a secondary diode short circuit.

8.9 OverTemperature Protection (OTP)

An accurate temperature protection is provided in the device. When the junction temperature exceeds the thermal shutdown temperature, the IC stops switching. During thermal protection, the IC current is lowered to the start-up current. The IC continues normal operation as soon as the overtemperature situation has disappeared.

8.10 OverVoltage Protection (OVP)

Overvoltage protection can be achieved in the application by pulling pin REG above its normal operation level. The current primary stroke is terminated immediately. No new primary stroke is started until the voltage on pin REG drops to its normal operation level. Pin REG has an internal clamp. The current feed into this pin must be limited.

8.11 Characteristics of complete LED power supply

8.11.1 Input

The input voltage range comprises the universal AC mains from 80 V to 276 V.

8.11.2 Accuracy

The accuracy of the complete converter, functioning as a voltage source with primary sensing, is approximately 8 % (mainly dependent on the transformer coupling). The accuracy with secondary sensing is defined by the accuracy of the external components. For safety requirements in case of opto coupler feedback loss, the primary sensing remains active when an overvoltage circuit is connected.

8.11.3 Efficiency

An efficiency over 80 % at maximum output power can be achieved for a complete converter designed for universal mains.

8.11.4 Ripple

A minimum ripple is obtained in a system designed for a maximum duty factor of 50 % under normal operating conditions and a minimized dead time. The magnitude of the ripple in the output voltage is determined by the frequency and duty factor of the converter, the output current level, and the value and ESR of the output capacitor.

8.11.5 Output

The SSL152x family can handle a wide range of output power levels up to 15 W through the selection of RDson.

9. Limiting values

Table 4. Limiting values

In accordance with the Absolute Maximum Rating System (IEC 60134). All voltages are measured with respect to ground; positive currents flow into the device; pins V_{CC} and RC are not allowed to be current driven and pins REG and AUX are not allowed to be voltage driven.

Symbol	Parameter	Conditions	Min	Max	Unit
Voltages					
V_{CC}	supply voltage	continuous	-0.4	+40	V
V_{RC}	voltage on pin RC	oscillator input voltage	-0.4	+3	V
V_{SOURCE}	voltage on pin SOURCE	DMOS power transistor	-0.4	+5	V
V_{DRAIN}	voltage on pin DRAIN	DMOS power transistor; $T_j > 0\text{ }^\circ\text{C}$	-0.4	+650	V
Currents					
I_{REG}	current on pin REG		-	6	mA
I_{AUX}	current on pin AUX		-10	+5	mA
I_{source}	source current	SSL1522T	-1	+1	A
		SSL1523P	-2	+2	A
I_{DRAIN}	current on pin DRAIN	SSL1522T	-1	+1	A
		SSL1523P	-2	+2	A
General					
P_{tot}	total power dissipation	DIP8 package; $T_{amb} < 45\text{ }^\circ\text{C}$	-	1.0	W
		SO14 package; $T_{amb} < 50\text{ }^\circ\text{C}$	-	1.0	W
T_{stg}	storage temperature		-55	+150	$^\circ\text{C}$
T_{amb}	ambient temperature		-40	+85	$^\circ\text{C}$
T_j	junction temperature		-40	+145	$^\circ\text{C}$
V_{esd}	electrostatic discharge voltage	human body model [1]	-	± 2500	V
		machine model [2]	-	± 200	V

[1] Human body model: equivalent to discharging a 100 pF capacitor through a 1.5 k Ω series resistor. All pins are 2500 V maximum, except pin DRAIN, which is 1000 V maximum.

[2] Machine model: equivalent to discharging a 200 pF capacitor through a 0.75 μH coil and a 10 Ω series resistor.

10. Thermal characteristics

Table 5. Thermal characteristics

Symbol	Parameter	Conditions	Typ	Unit
$R_{th(j-a)}$	thermal resistance from junction to ambient	in free air [1]		
		DIP8 package	100	K/W
		SO14 package	91	K/W

[1] Thermal resistance $R_{th(j-a)}$ can be lower when the GND pins are connected to sufficient copper area on the printed-circuit board. See the SSL152x application notes for details.

11. Characteristics

Table 6. Characteristics

Measurement data valid at $T_{amb} = 25\text{ }^\circ\text{C}$; no overtemperature; all voltages are measured with respect to ground; currents are positive when flowing into the IC; unless otherwise specified.

Symbol	Parameter	Conditions	Min	Typ	Max	Unit
Supply						
$I_{CC(oper)}$	operating supply current	normal operation	-	1.3	1.9	mA
$I_{CC(startup)}$	start-up supply current	start-up	-	180	400	μA
I_{CC}	supply current	$V_{DRAIN} > 60\text{ V}$	-6	-4	-3	mA
$V_{CC(startup)}$	start-up supply voltage		9	9.5	10	V
$V_{CC(stop)}$	stop supply voltage	undervoltage lockout	7.0	7.5	8.0	V
I_{DRAIN}	current on pin DRAIN	$V_{DRAIN} > 60\text{ V}$				
		no auxiliary supply	-	1.5	2	mA
		with auxiliary supply	-	30	125	μA
Pulse width modulator						
δ_{min}	minimum duty factor		-	0	-	%
δ_{max}	maximum duty cycle	$f = 100\text{ kHz}$	-	75	-	%
SOPS						
$V_{det(demag)}$	demagnetization detection voltage		50	100	150	mV
$t_{sup(xfmr_ring)}$	transformer ringing suppression time		1.0	1.5	2.0	μs
RC oscillator						
$V_{RC(min)}$	minimum voltage on pin RC		60	75	90	mV
$V_{RC(max)}$	maximum voltage on pin RC		2.4	2.5	2.6	V
t_{ch}	charge time		-	1	-	μs
f_{osc}	oscillator frequency		10	100	200	kHz
Duty factor regulator: pin REG						
V_{REG}	voltage on pin REG		2.4	2.5	2.6	V
G_v	voltage gain		-	20	-	dB
$V_{clamp(REG)}$	clamp voltage on pin REG	$I_{REG} = 6\text{ mA}$	-	-	7.5	V
Valley switching						
$(\Delta V/\Delta t)_{vrec}$	valley recognition voltage change with time		-102	-	+102	$\text{V}/\mu\text{s}$
f_{ring}	ringing frequency	$N \times V_o = 100\text{ V}$	200	550	800	kHz
$t_{d(vrec-swon)}$	valley recognition to switch-on delay time		-	150	-	ns
Current and short-circuit winding protection						
$V_{SOURCE(max)}$	maximum voltage on pin SOURCE	$\Delta V/\Delta t = 0.1\text{ V}/\mu\text{s}$	0.47	0.50	0.53	V
t_d	delay time	$\Delta V/\Delta t = 0.5\text{ V}/\mu\text{s}$	-	160	185	ns
V_{swp}	short-winding protection voltage	$\Delta V/\Delta t = 0.5\text{ V}/\mu\text{s}$	0.7	0.75	0.8	V
t_{leb}	leading edge blanking time		250	350	450	ns

Table 6. Characteristics ...continued

Measurement data valid at $T_{amb} = 25\text{ °C}$; no overtemperature; all voltages are measured with respect to ground; currents are positive when flowing into the IC; unless otherwise specified.

Symbol	Parameter	Conditions	Min	Typ	Max	Unit	
FET output stage							
$I_{L(DRAIN)}$	leakage current on pin DRAIN	$V_{DRAIN} = 650\text{ V}$	-	-	125	μA	
$V_{BR(DRAIN)}$	breakdown voltage on pin DRAIN	$T_j > 0\text{ °C}$	650	-	-	V	
R_{DSon}	drain-source on-state resistance	SSL1522T; $I_{source} = -0.25\text{ A}$					
		$T_j = 25\text{ °C}$	-	12	13.8	Ω	
		$T_j = 100\text{ °C}$	-	17	19.6	Ω	
		SSL1523P; $I_{source} = -0.50\text{ A}$					
		$T_j = 25\text{ °C}$	-	6.5	7.5	Ω	
		$T_j = 100\text{ °C}$	-	9.0	10.0	Ω	
$t_f(DRAIN)$	fall time on pin DRAIN	$V_i = 300\text{ V}$; no external capacitor at drain	-	75	-	ns	
Temperature protection							
T_{prot}	protection temperature		150	160	170	$^{\circ}\text{C}$	
$T_{prot(hys)}$	hysteresis of protection temperature		-	2	-	$^{\circ}\text{C}$	

13. Package outline

DIP8: plastic dual in-line package; 8 leads (300 mil)

SOT97-1

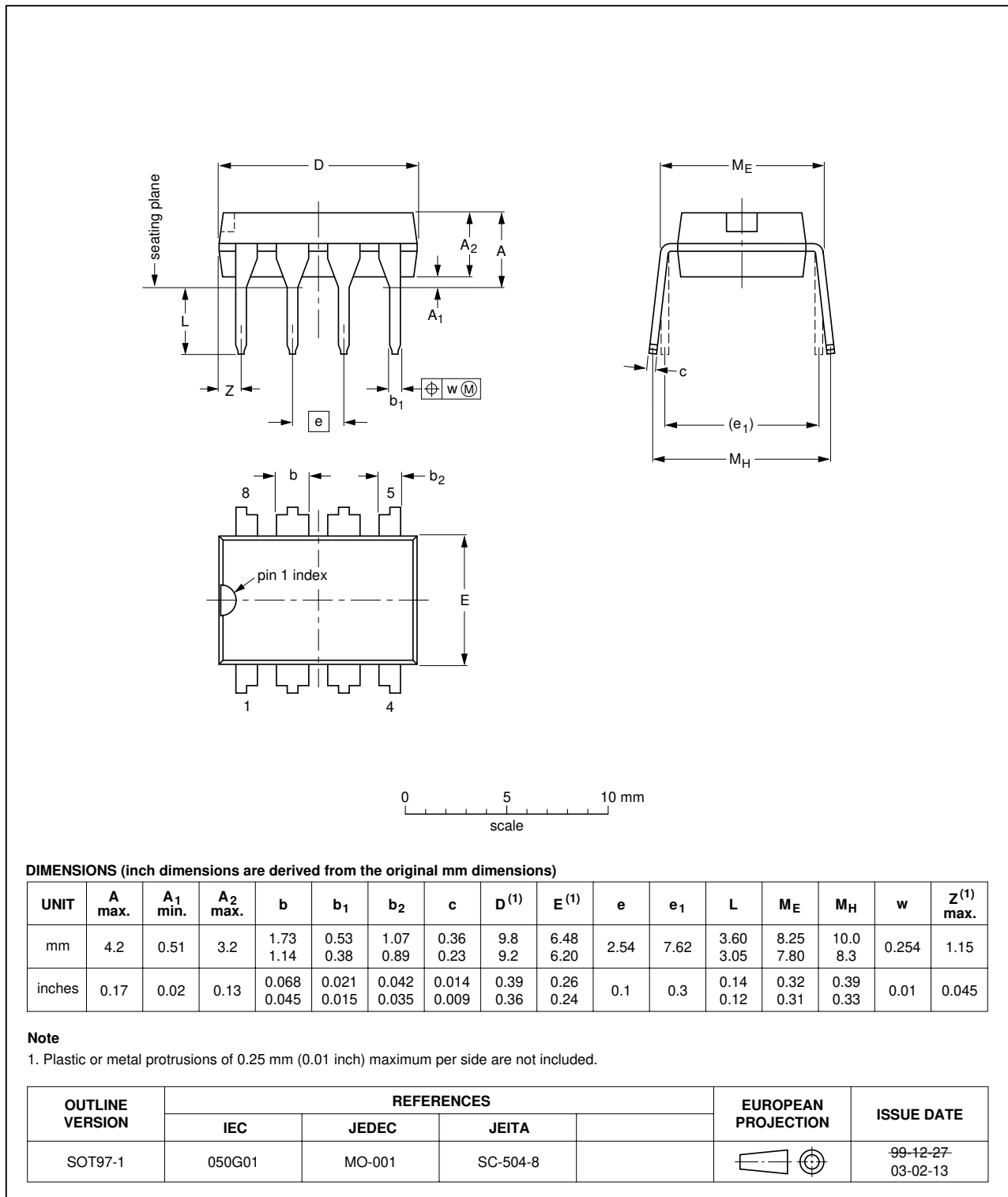

Fig 7. Package outline SOT97-1 (DIP8)

SO14: plastic small outline package; 14 leads; body width 3.9 mm

SOT108-1

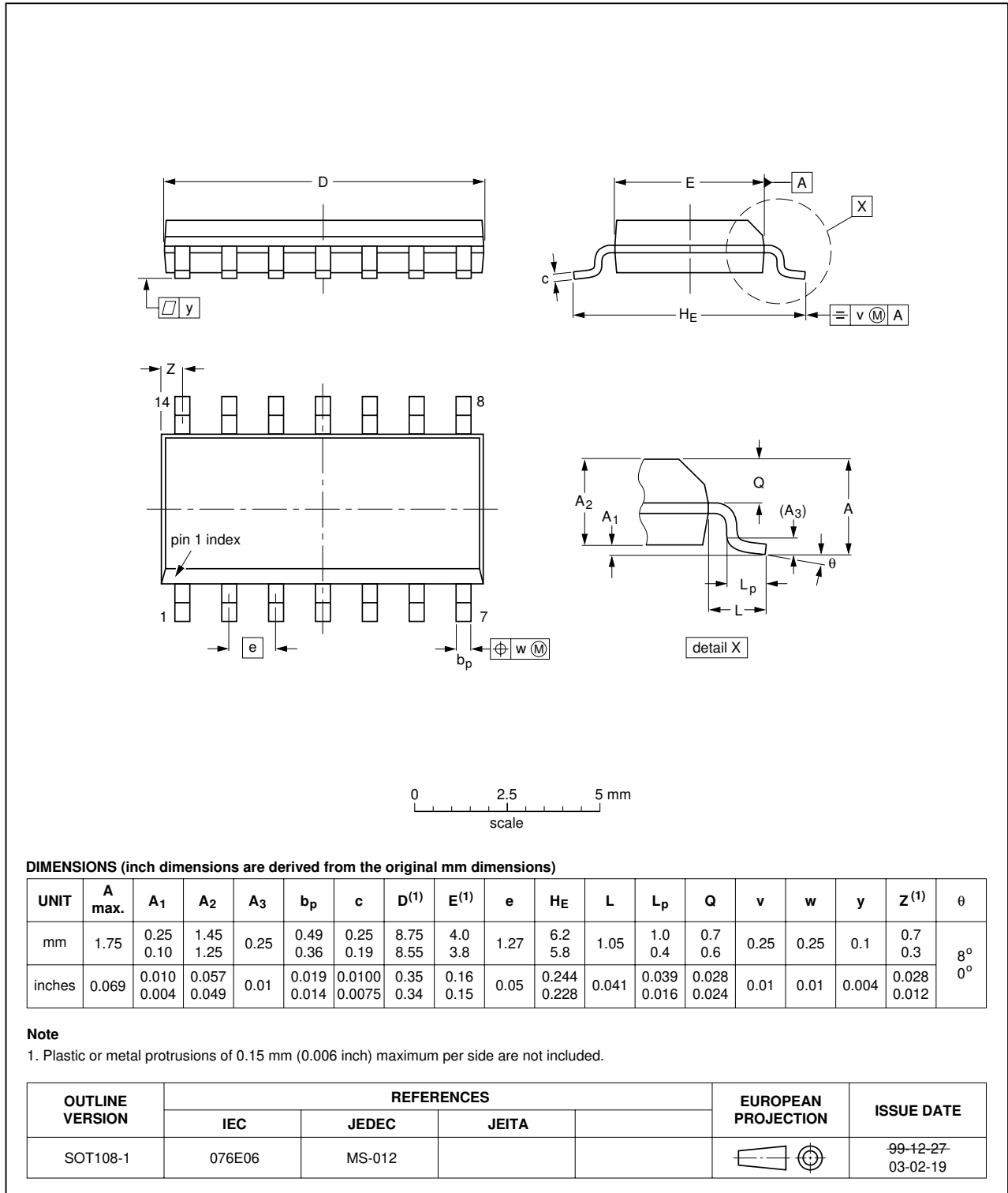

Fig 8. Package outline SOT108-1 (SO14)

14. Abbreviations

Table 7. Abbreviations

Acronym	Description
BiCMOS	Bipolar Complementary Metal Oxide Semiconductor
DMOS	Diffusion Metal Oxide Semiconductor
ESR	Equivalent Series Resistance
EZ-HV SOI	Easy High Voltage Silicon-On-Insulator
FET	Field-Effect Transistor
SMPS	Switched Mode Power Supply
SOPS	Self Oscillating Power Supply

15. Revision history

Table 8. Revision history

Document ID	Release date	Data sheet status	Change notice	Doc. number	Supersedes
SSL152X_2	20090310	Product data sheet	-	-	SSL152X_1
Modifications:					<ul style="list-style-type: none"> The minimum value of T_{amb} has changed in Table 1 and Table 4. The minimum value of T_j has changed in Table 4.
SSL152X_1	20080915	Product data sheet	-	-	-

16. Legal information

16.1 Data sheet status

Document status ^{[1][2]}	Product status ^[3]	Definition
Objective [short] data sheet	Development	This document contains data from the objective specification for product development.
Preliminary [short] data sheet	Qualification	This document contains data from the preliminary specification.
Product [short] data sheet	Production	This document contains the product specification.

[1] Please consult the most recently issued document before initiating or completing a design.

[2] The term 'short data sheet' is explained in section "Definitions".

[3] The product status of device(s) described in this document may have changed since this document was published and may differ in case of multiple devices. The latest product status information is available on the Internet at URL <http://www.nxp.com>.

16.2 Definitions

Draft — The document is a draft version only. The content is still under internal review and subject to formal approval, which may result in modifications or additions. NXP Semiconductors does not give any representations or warranties as to the accuracy or completeness of information included herein and shall have no liability for the consequences of use of such information.

Short data sheet — A short data sheet is an extract from a full data sheet with the same product type number(s) and title. A short data sheet is intended for quick reference only and should not be relied upon to contain detailed and full information. For detailed and full information see the relevant full data sheet, which is available on request via the local NXP Semiconductors sales office. In case of any inconsistency or conflict with the short data sheet, the full data sheet shall prevail.

16.3 Disclaimers

General — Information in this document is believed to be accurate and reliable. However, NXP Semiconductors does not give any representations or warranties, expressed or implied, as to the accuracy or completeness of such information and shall have no liability for the consequences of use of such information.

Right to make changes — NXP Semiconductors reserves the right to make changes to information published in this document, including without limitation specifications and product descriptions, at any time and without notice. This document supersedes and replaces all information supplied prior to the publication hereof.

Suitability for use — NXP Semiconductors products are not designed, authorized or warranted to be suitable for use in medical, military, aircraft, space or life support equipment, nor in applications where failure or malfunction of an NXP Semiconductors product can reasonably be expected to result in personal injury, death or severe property or environmental

damage. NXP Semiconductors accepts no liability for inclusion and/or use of NXP Semiconductors products in such equipment or applications and therefore such inclusion and/or use is at the customer's own risk.

Applications — Applications that are described herein for any of these products are for illustrative purposes only. NXP Semiconductors makes no representation or warranty that such applications will be suitable for the specified use without further testing or modification.

Limiting values — Stress above one or more limiting values (as defined in the Absolute Maximum Ratings System of IEC 60134) may cause permanent damage to the device. Limiting values are stress ratings only and operation of the device at these or any other conditions above those given in the Characteristics sections of this document is not implied. Exposure to limiting values for extended periods may affect device reliability.

Terms and conditions of sale — NXP Semiconductors products are sold subject to the general terms and conditions of commercial sale, as published at <http://www.nxp.com/profile/terms>, including those pertaining to warranty, intellectual property rights infringement and limitation of liability, unless explicitly otherwise agreed to in writing by NXP Semiconductors. In case of any inconsistency or conflict between information in this document and such terms and conditions, the latter will prevail.

No offer to sell or license — Nothing in this document may be interpreted or construed as an offer to sell products that is open for acceptance or the grant, conveyance or implication of any license under any copyrights, patents or other industrial or intellectual property rights.

Export control — This document as well as the item(s) described herein may be subject to export control regulations. Export might require a prior authorization from national authorities.

Quick reference data — The Quick reference data is an extract of the product data given in the Limiting values and Characteristics sections of this document, and as such is not complete, exhaustive or legally binding.

16.4 Trademarks

Notice: All referenced brands, product names, service names and trademarks are the property of their respective owners.

17. Contact information

For more information, please visit: <http://www.nxp.com>

For sales office addresses, please send an email to: salesaddresses@nxp.com

18. Contents

1 General description 1

2 Features 1

3 Applications 2

4 Quick reference data 2

5 Ordering information 2

6 Block diagram 3

7 Pinning information 4

7.1 Pinning 4

7.2 Pin description 4

8 Functional description 5

8.1 Start-up and undervoltage lockout 5

8.2 Oscillator 5

8.3 Duty factor control 5

8.4 Valley switching 6

8.5 Demagnetization 7

8.6 Minimum and maximum duty factor 7

8.7 OverCurrent Protection (OCP) 7

8.8 Short circuit winding protection 7

8.9 OverTemperature Protection (OTP) 8

8.10 OverVoltage Protection (OVP) 8

8.11 Characteristics of complete LED power supply 8

8.11.1 Input 8

8.11.2 Accuracy 8

8.11.3 Efficiency 8

8.11.4 Ripple 8

8.11.5 Output 8

9 Limiting values 9

10 Thermal characteristics 9

11 Characteristics 10

12 Application information 12

13 Package outline 13

14 Abbreviations 15

15 Revision history 15

16 Legal information 16

16.1 Data sheet status 16

16.2 Definitions 16

16.3 Disclaimers 16

16.4 Trademarks 16

17 Contact information 16

18 Contents 17

Please be aware that important notices concerning this document and the product(s) described herein, have been included in section 'Legal information'.



© NXP B.V. 2009.

All rights reserved.

For more information, please visit: <http://www.nxp.com>
 For sales office addresses, please send an email to: salesaddresses@nxp.com

Date of release: 10 March 2009
 Document identifier: SSL152X_2