



Chipsmall Limited consists of a professional team with an average of over 10 year of expertise in the distribution of electronic components. Based in Hongkong, we have already established firm and mutual-benefit business relationships with customers from,Europe,America and south Asia,supplying obsolete and hard-to-find components to meet their specific needs.

With the principle of “Quality Parts,Customers Priority,Honest Operation,and Considerate Service”,our business mainly focus on the distribution of electronic components. Line cards we deal with include Microchip,ALPS,ROHM,Xilinx,Pulse,ON,Everlight and Freescale. Main products comprise IC,Modules,Potentiometer,IC Socket,Relay,Connector.Our parts cover such applications as commercial,industrial, and automotives areas.

We are looking forward to setting up business relationship with you and hope to provide you with the best service and solution. Let us make a better world for our industry!



Contact us

Tel: +86-755-8981 8866 Fax: +86-755-8427 6832

Email & Skype: info@chipsmall.com Web: www.chipsmall.com

Address: A1208, Overseas Decoration Building, #122 Zhenhua RD., Futian, Shenzhen, China





SSL5511T

Greenchip controller for LED lighting with DIM pin

Rev. 2 — 30 June 2014

Product data sheet

1. General description

The SSL5511T is an offline dimmable controller IC, intended to drive dimmable LEDs in general lighting applications, like remote-controlled luminaires and smart lamps.

The main benefits of this IC include:

- Dim level control with either an analog or a digital control input
- Selectable modes for high power factor or low ripple, allowing a wide LED power range
- Large dimming range
- Single stage topology for small PCB footprint
- Ease of design-in
- Integrated start-up JFET
- Low electronic Bill Of Material (BOM)
- Various converter topologies supported

The IC drives an external switch for easy power scaling. It has been designed to start up directly from the High-Voltage (HV) supply by an internal high-voltage current source. Flyback, buck and buck-boost circuit topologies are supported. Primary side sensing provides accurate output current control.

The IC can detect analog signals (according to IEC60929 annex E) or digital control signals and translate them to a continuous LED current in multiple ways. It can operate in three switching modes at two switching frequency ranges. It offers tradeoffs between the output current ripple, the mains current Total Harmonic Distortion (THD) and the application size. The IC incorporates all required protection features.



2. Features and benefits

- LED controller IC for driving strings of LEDs or high-voltage LEDs from rectified mains
- High-efficiency switch mode buck, flyback or buck-boost controller driving an external power FET
 - ◆ Two maximum switching frequencies for highest efficiency or smallest application size
 - ◆ Zero current switching at switch turn-on
 - ◆ Zero voltage or valley switching at switch turn-on
 - ◆ Selectable low THD or low LED current ripple modes
- Analog IEC60929 input or digital control input for dimming
- Continuous (analog) regulation of LED current in both the dimming control modes
- Dim curve selection based on the control input type
- No binning on LED forward voltage required
- LED current accuracy within $\pm 4\%$ across variations in components and conditions
- Built-in Protections:
 - ◆ UnderVoltage LockOut (UVLO)
 - ◆ Leading Edge Blanking (LEB)
 - ◆ OverCurrent Protection (OCP)
 - ◆ Internal OverTemperature Protection (OTP)
 - ◆ Brownout protection
 - ◆ Output Short Protection (OSP)
 - ◆ Output open OverVoltage Protection (OVP)
 - ◆ Mains synchronization loss protection
- Low component count LED driver solution
- Compatible with wall switches with built-in indication light during standby()
- IC lifetime matches or surpasses LED lamp lifetime

3. Applications

- Compact mains connected, remote-controlled LED lamps with accurate, dimmable current output for single or universal mains voltages, including 100 V (AC), 120 V (AC) and 230 V (AC). External components determine the power level. The power level ranges from 4 W to over 25 W. Applications fit in common form factors like PAR, GU10, A19, and the candle form factor.

4. Quick reference data

Table 1. Quick reference data

Symbol	Parameter	Conditions	Min	Typ	Max	Unit
V_{CC}	supply voltage		8.8	-	32	V
f_{sw}	switching frequency	low-frequency mode; undimmed				
		50 Hz mains	55	60	65	kHz
		60 Hz mains	66	72	78	kHz
		high-frequency mode; undimmed				
		50 Hz mains	84	91	98	kHz
		60 Hz mains	101	109	117	kHz
I_{CC}	supply current	normal operation	-	2.25	-	mA
$V_{I(DRAIN)}$	input voltage on pin DRAIN	not repetitive	-	-	700	V
$V_{O(PWRDRV)}$	output voltage on pin PWRDRV	high level	-	10.7	-	V

5. Ordering information

Table 2. Ordering information

Type number	Package		Version
	Name	Description	
SSL5511T	SO8	plastic small package outline body; 8 leads; body width 3.9 mm	SOT96-1

6. Block diagram

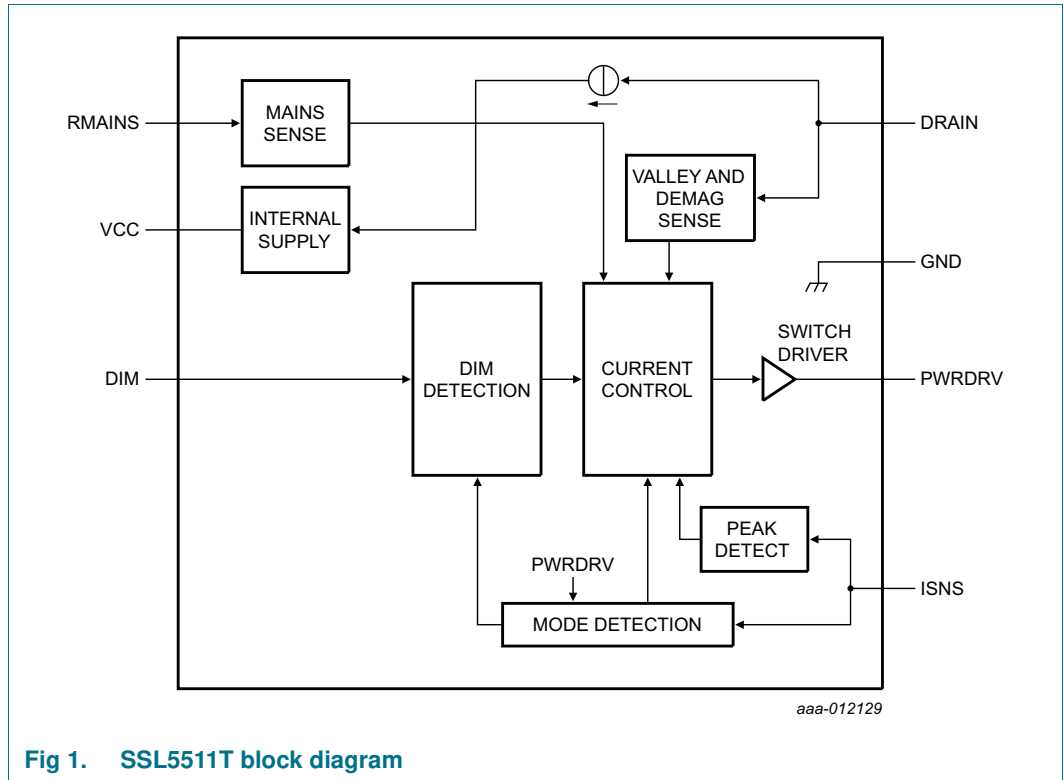

Fig 1. SSL5511T block diagram

7. Pinning information

7.1 Pinning

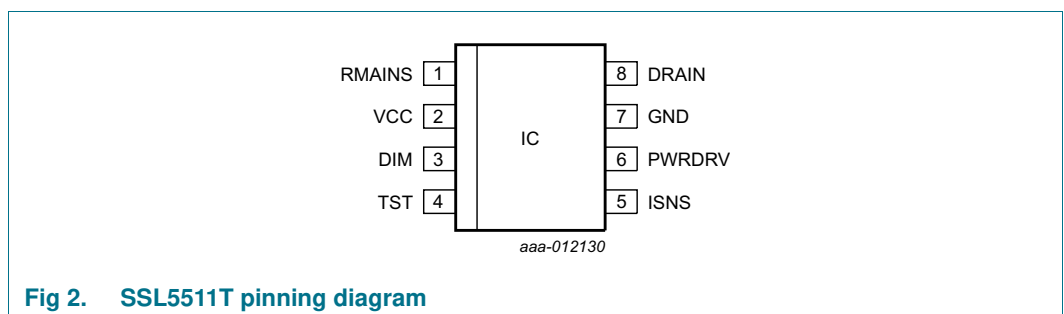

Fig 2. SSL5511T pinning diagram

7.2 Pin description

Table 3. Pin description

Symbol	Pin	Description
RMAINS	1	mains detection input
VCC	2	IC supply input/output
DIM	3	dim-level control input
TST	4	IC test pin, to be connected to ground in application
ISNS	5	peak current sense input
PWRDRV	6	external MOSFET gate driver output
GND	7	ground
DRAIN	8	external MOSFET drain sense input

8. Functional description

8.1 Pin functionality

8.1.1 Pin RMAINS

The RMAINS pin takes in a current representing the rectified mains voltage via the external RMAINS resistors. The low ohmic input results in current always flowing, causing the voltage on the RMAINS pin to remain below the maximum $V_{i(RMAINS)}$ at any time. The information about the mains voltage is used to shape the output current waveform in LTHD modes. It is also used for internal timing synchronizations, making it essential for the low-ripple applications. Some filtering may be required outside the IC to eliminate incoming noise.

If the pin does not receive a rectified mains signal, the mains synchronization loss protection is triggered.

8.1.2 Pin VCC

At power-up, the VCC pin and its capacitor are charged using the internal HV current source from the DRAIN pin. Once V_{CC} has reached $V_{CC(startup)}$, switching starts and V_{CC} supply is generated from the auxiliary winding. If V_{CC} exceeds $V_{ovp(VCC)}$ due to, for example, a disconnected output, OVP is triggered. If V_{CC} drops to $V_{CC(low)}$, the internal HV current source is enabled. If V_{CC} drops to below $V_{CC(stop)}$, UVLO protection is triggered.

Do not use the VCC pin to power additional circuitry outside the IC because no additional current budget is guaranteed. An additional V_{CC} load can affect product performance.

To support wall switches that include an indicator light, a predetermined current (I_{CC}) is pulled from the supply during a limited window of the VCC voltage (see condition 2 of I_{CC} in [Table 7](#)).

8.1.3 Pin DIM

The DIM pin is the dimming level control pin. It also acts as the on/off control pin. It accepts both an analog voltage signal and a digital control signal as input. The type of input signal is automatically detected and the input is then translated into a target output current level (see [Section 8.2.6](#)).

8.1.4 Pin ISNS

The ISNS pin senses the voltage across the sense resistor, R_{SNS} , generated by the inductor current flowing through the external MOSFET and this resistor (see [Figure 3](#)).

Optionally, a mode definition resistor is present between the pin and the current sense resistor. At start-up, the mode resistor is measured using a current which is sourced out of the pin.

8.1.5 Pin PWRDRV

The SSL5511T is equipped with a driver that controls an external MOSFET. The voltage on the driver output pin is increased towards the maximum $V_{O(PWRDRV)}$ to open the switch during the first cycle (t_0 to t_1 ; see [Figure 4](#)). It is pulled to ground from the start of the secondary stroke until the next cycle starts (t_1 to t_{00}). During the transition from low to high and back, the switching slope is controlled, limiting the high-frequency radiation.

8.1.6 Pin DRAIN

The DRAIN pin is used to derive energy to charge the VCC pin at start-up and after switching is stopped because of a triggered protection. The signal at the DRAIN pin is also used to detect demagnetization and to determine the valley of the ringing voltage for starting the primary stroke.

8.2 Converter operation

8.2.1 Available modes

The SSL5511T incorporates various built-in operation modes which can be selected in the application using a maximum of two external resistors. At start-up, the value of these resistors is detected and the corresponding operation mode is set.

The mode resistor at the PWRDRV (R_{TF}) is connected to ground. The mode resistor at the ISNS pin (R_{CTL}) is connected between the pin and the external MOSFET source (see [Figure 3](#)).

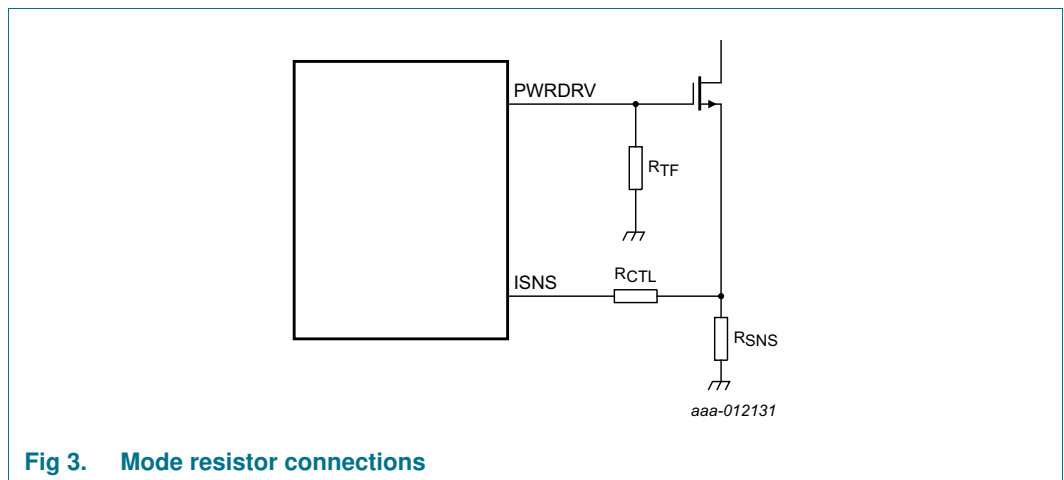

Fig 3. Mode resistor connections

Table 4 gives an overview of the available modes.

Table 4. Available modes

Parameter	How to set	Options	Mode resistor value
topology and frequency	R _{TF} on pin PWRDRV	flyback or buck-boost; HF mode	∞
		buck; HF mode	56 kΩ
		buck; LF mode	33 kΩ
		flyback or buck-boost; LF mode	15 kΩ
control mode	R _{CTL} on pin ISNS	low ripple (PF < 0.7)	0 kΩ to 0.5 kΩ or 3.3 kΩ
		eco-LTHD (PF ~ 0.75)	1.5 kΩ
		LTHD (PF > 0.9)	5.6 kΩ

8.2.2 Switching scheme

The converter in the SSL5511T is a Discontinuous Conduction Mode (DCM), peak current controlled system. When the output current control system requires a new switching cycle and the inductor current is zero, the external MOSFET is turned on at the next detected valley (see Section 8.2.3). The inductor current increases until a maximum, defined by the regulation loop, is reached and the MOSFET is switched off. The inductor current reduces again. When the inductor current reaches zero, it is detected at the DRAIN pin. The detection enables the control system to regulate to an accurate average value of the LED current.

The maximum switching frequency can be set at two rates (see Section 8.2.1).

Three options are available which determine how the controller adjusts the maximum inductor peak current over the mains cycle. The result is either an optimal input current shape (optimized power factor and THD), a minimal LED current ripple, or an intermediate solution (eco-LTHD mode).

8.2.3 Valley detection

A new cycle is started when the primary switch is switched on (see Figure 4). At a certain time (t₁), the switch is turned off and the secondary stroke starts. After the secondary stroke (t₃), the drain voltage shows oscillation or ringing. Circuitry at the DRAIN pin senses when the voltage on the drain of the switch has reached its lowest value (valley) during each oscillation. When the control loop requires the next cycle, it is started the next time a valley occurs. As a result, the capacitive switching losses reduce significantly. For successful valley detection, the frequency and amplitude of the drain voltage ringing must cause the slope of the ringing voltage to exceed the detection limit (dV/dt)_{vrec} for at least t_{d(vrec-swon)}.

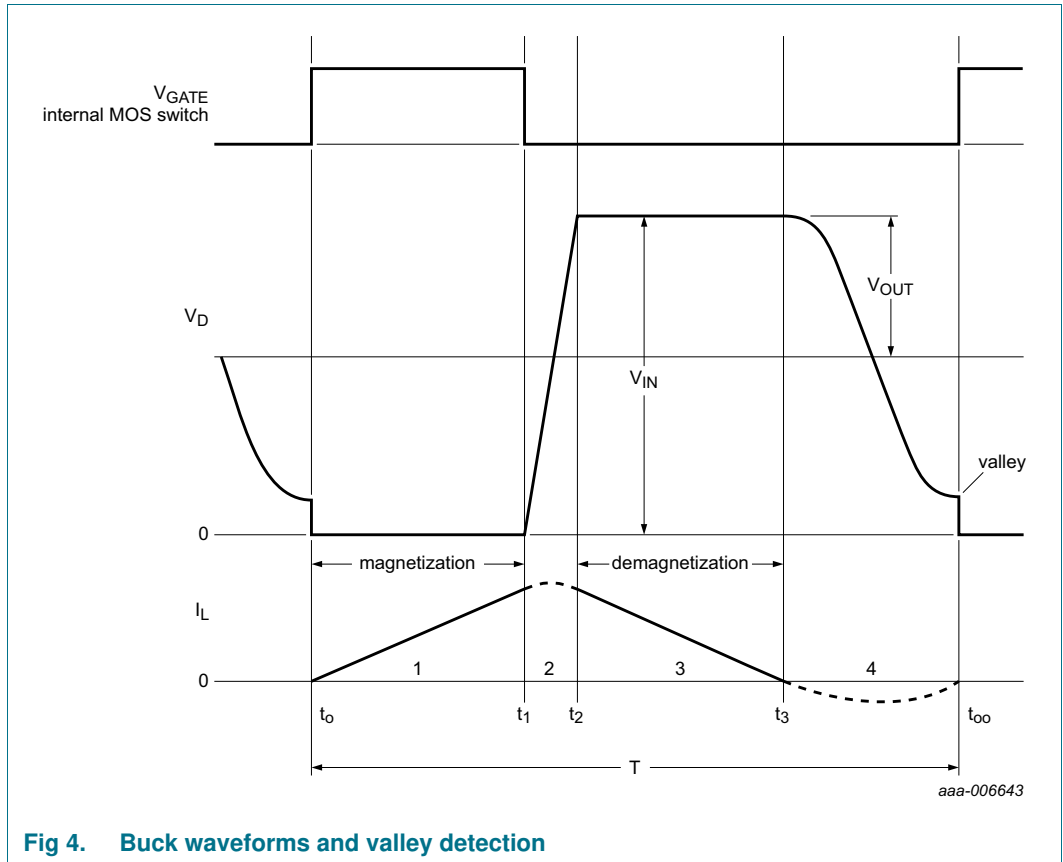

Fig 4. Buck waveforms and valley detection

8.2.4 Output current settings

The IC regulates the output LED current with great accuracy over line, load and component variations. The user can set the full-scale (100 %) value of the LED current. Choose a current sense resistor value according to [Equation 1](#):

$$I_{LED} = \frac{V_{reg}}{R_{SNS}} \times N \tag{1}$$

Where:

- V_{reg} is the set point of the internal regulation loop: 117 mV for LTHD buck-boost/flyback, 234 mV for LTHD buck and low ripple buck-boost/flyback, and 469 mV for low-ripple buck
- R_{SNS} is the sense resistor on pin ISNS (see [Figure 3](#))
- N is the transformer ratio

The IC regulates the output current by controlling the current sense threshold voltage V_{th(ISNS)}, the number of switching cycles per (half-)mains period, and, if necessary, the switching frequency, depending on the mode of operation.

8.2.5 Preventing Continuous Conduction Mode (CCM)

To enable application design without having to include margins to ensure DCM operation, a CCM-prevention feature has been built in. The IC monitors the time gap between the end of the secondary stroke and the start of the next cycle. If this time becomes shorter than a predetermined idle time of about 1.8 μs , the controller reduces the switching frequency.

8.2.6 Dimming support

The SSL5511T accepts one of two different types of control signals on the DIM pin, either an analog voltage signal or a digital control signal. The type of the dimming control is detected during start-up. If digital switching occurs on the DIM pin, or if a voltage above the analog dimming input range ($V_{\text{ctrl(A)DIM}}$) is present on the pin, digital dimming control is detected. If a voltage within the analog range ($V_{\text{ctrl(A)DIM}}$) is present on the pin, then analog dimming control is detected. If the input remains low (below the analog dimming range), the target output current level is set to zero, and standby mode is entered. Dim mode selection is then postponed until one of the above detection conditions is met. Once the dimming type is detected, it is set fixed until power-down. During operation in either analog or digital dimming mode, the measurement of the DIM pin is done once in every full mains cycle. For both dimming control types, the output current regulation remains analog.

- Analog Input Dimming Control (AIDC):

In this mode, an input voltage within the analog range ($V_{\text{ctrl(A)DIM}}$) is accepted on the DIM pin and translated to a target output current level. [Figure 5](#) shows the plotting of the dimming percentage of the output current against the input voltage. The smooth tail of the curve matches human eye light sensitivity. The minimum output current level as a ratio of the full-scale current is $I_{\text{LEDlow}}/I_{\text{LED100}}$. If the input voltage drops to below the analog range by more than the built-in hysteresis ($V_{\text{hys(low)DIM}}$), the output current is set to zero. The IC enters standby mode. Some filtering may be required outside the IC to eliminate incoming noise.

- Digital Input Dimming Control (DIDC):

A digital signal of a frequency within the range $f_{i(\text{DIM})}$, and levels satisfying the thresholds $V_{\text{th(L)DIM}}$ and $V_{\text{th(H)DIM}}$ are accepted and translated to a target LED current level. The dimming percentage of the output current equals the duty cycle of the input signal (expressed as a percentage; see [Figure 6](#)). The minimum output current level as a ratio of the full-scale current is $I_{\text{LEDlow}}/I_{\text{LED100}}$. If the input signal is low for longer than $t_{\text{det(stb)DIM}}$ in the measurement window, the output current is set to zero. The IC enters standby mode.

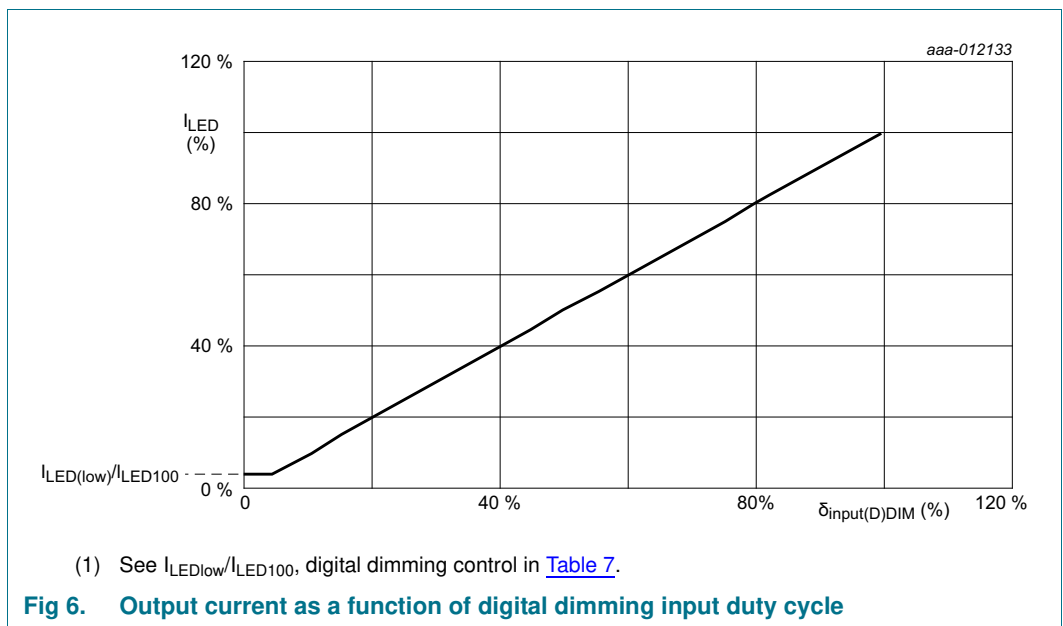
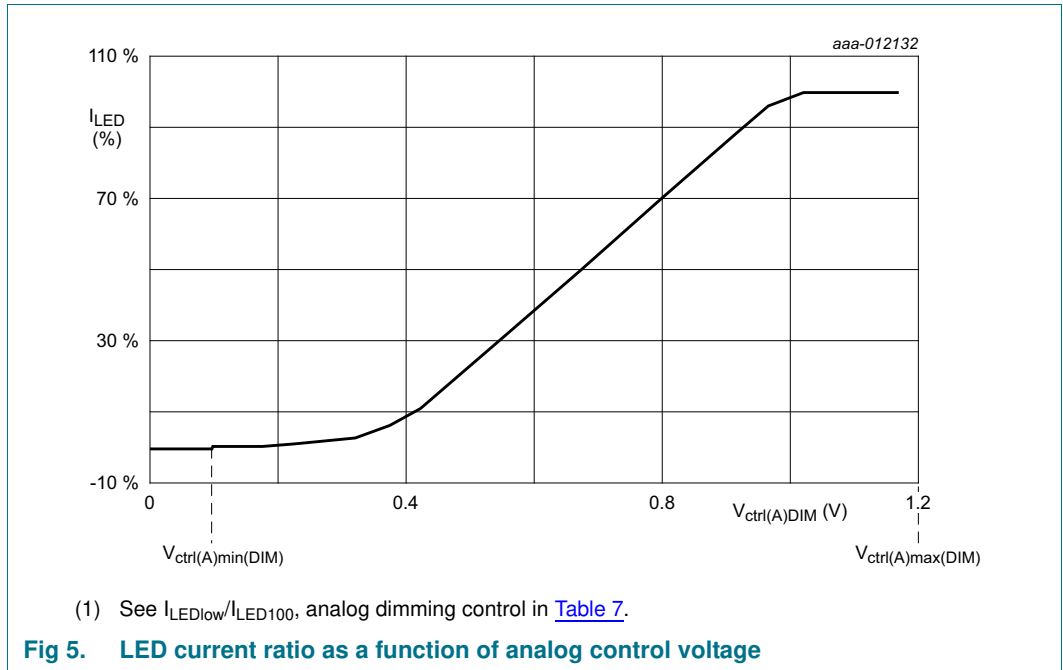

8.3 Protections

The IC incorporates the following protections:

- UnderVoltage LockOut (UVLO)
- OverCurrent Protection (OCP)
- Brownout Protection
- Output Short Protection (OSP)
- Output open OverVoltage Protection (OVP)
- Internal OverTemperature Protection (OTP)
- Mains synchronization loss protection
- Leading Edge Blanking (LEB)

Output open OVP is a latched protection. Power-off cycling is required to exit the latched state. All other protections are not latched and lead to a safe restart of the converter.

8.3.1 UnderVoltage LockOut (UVLO)

When the voltage on the VCC pin drops to below the value of $V_{CC(stop)}$, the IC stops switching. The internal HV current source is enabled. Once V_{CC} has increased to $V_{CC(startup)}$, the IC restarts a minimum of 1 s back-off time.

8.3.2 OverCurrent Protection (OCP)

The SSL5511T contains a highly accurate peak current detector. It triggers when the voltage at pin ISNS reaches $V_{th(ISNS)}$. The circuit is activated after the leading edge blanking time (t_{leb}). There is a propagation delay between the peak current detection and the switch actually switching off. Due to this delay, the actual peak current is slightly higher than the peak current level set by the current sense resistor. The control loop compensates for this difference ensuring output current accuracy.

8.3.3 Brownout protection

The brownout protection is designed to limit the switch-on time in case of low input voltage. Because of the built-in peak current control, the input current otherwise slowly increases while no power is transferred to the output in a flyback configuration. The SSL5511T includes a maximum on-time of the switch $t_{on(high)}$.

8.3.4 Output short protection (OSP)

During the secondary stroke (switch-off time), if a valley is not detected within the off-time limit ($t_{off(high)}$), the output voltage is typically less than the minimum limit allowed in the application. This condition can occur either during start-up or due to a short. A timer is started when $t_{off(high)}$ is detected. It is only stopped if a valid valley-detection occurs in one of the subsequent cycles. If no valley is detected for $t_{det(sc)}$, it is concluded that a real short-circuit exists and not a temporary start-up situation. The IC enters standby mode and tries to restart after a minimum of 9 s back-off time.

8.3.5 Output open OverVoltage Protection (OVP)

The result of an output open situation is that no power is delivered to the output, causing V_{CC} to exceed $V_{CC(max)}$. Upon detection of this event, the IC enters the standby mode. As long as mains voltage is present, the IC does not restart.

8.3.6 Internal OverTemperature Protection (OTP)

When the internal OTP function is triggered, the converter stops operating. This function is triggered at $T_{th(act)otp}$. The Overtemperature protection is an auto-restart protection. The IC restarts when the IC temperature drops to below $T_{th(rel)otp}$.

8.3.7 Mains synchronization loss protection

When the input current at the RMAINS pin fails to cross the "zero crossing detection" value of $I_{i(RMAINS)}$, no mains cycles are detected. If this situation persists for a time $t_{d(mld)}$, the IC stops switching. Once a valid mains signal is available again, the IC restarts.

8.3.8 Leading Edge Blanking (LEB)

A blanking time is implemented after switch-on to prevent premature detection of inductor peak current. At the opening of the MOSFET switch, a short current spike can occur because of the capacitive discharge of voltage over the drain and source. During the leading edge blanking time (t_{leb}), detection is disabled. So spikes are disregarded.

9. Limiting values

Table 5. Limiting values

In accordance with the Absolute Maximum Rating System (IEC 60134).

Symbol	Parameter	Conditions	Min	Max	Unit
General					
P_{tot}	total power dissipation	SO8 package	-	0.6	W
T_{amb}	ambient temperature		-40	+125	°C
T_{j}	junction temperature		-40	+190	°C
T_{stg}	storage temperature		-55	+150	°C
SR	slew rate	pin DRAIN	-10	+10	V/ns
Pin voltages and currents					
V_{CC}	supply voltage		-0.4	+34	V
$V_{\text{i(RMAINS)}}$	input voltage on pin RMAINS	current limited	-0.4	+5.2	V
$I_{\text{i(RMAINS)}}$	input current on pin RMAINS	at $V_{\text{RMAINS}} = 5.2 \text{ V}$	0	2.5	mA
$V_{\text{i(ISNS)}}$	input voltage on pin ISNS		-0.4	+5.2	V
$V_{\text{i(DRAIN)}}$	input voltage on pin DRAIN	during mains surge; not repetitive	-0.4	+700	V
V_{ESD}	electrostatic discharge voltage	human body model [1]			
		all pins except pin DRAIN	-2000	+2000	V
		pin DRAIN	-1000	+1000	V
		charged device model [2]	-500	+500	V

[1] Human body model: equivalent to discharging a 100 pF capacitor through a 1.5 k Ω series resistor.

[2] Charged device model: equivalent to charging the IC up to 1 kV and the subsequent discharging of each pin down to 0 V over a 1 Ω resistor.

10. Thermal characteristics

Table 6. Thermal characteristics

Symbol	Parameter	Conditions	Typ	Unit
$R_{\text{th(j-a)}}$	thermal resistance from junction to ambient	in free air; PCB: 2 cm \times 3 cm; 2-layer; 35 μm Cu/layer	159	K/W
		in free air; PCB: JEDEC 2s2p	89	K/W
$\Psi_{\text{j-top}}$	thermal characterization parameter from junction to top of package	top package temperature measured at the warmest top of the case point	0.49	K/W

11. Characteristics

Table 7. Characteristics

Symbol	Parameter	Conditions	Min	Typ	Max	Unit
High voltage						
$V_{I(DRAIN)}$	input voltage on pin DRAIN	[1]	-	-	675	V
$I_{i(DRAIN)}$	input current on pin DRAIN	JFET on strong; $V_{DRAIN} = 675\text{ V};$ $V_{CC} = 17\text{ V}$	4	5.5	7	mA
		JFET off; $V_{DRAIN} = 675\text{ V};$ $V_{CC} = 20\text{ V}$	-	-	15	μA
		JFET on weak; $V_{DRAIN} = 675\text{ V}; V_{CC} < 4\text{ V}$	500	550	600	μA
Supply						
$V_{CC(startup)}$	start-up supply voltage		17.5	18.5	19.5	V
$V_{CC(low)}$	low supply voltage	pin VCC	11.2	11.8	12.4	V
$V_{CC(stop)}$	stop supply voltage		8.8	9.3	9.8	V
$V_{CC(hys)}$	hysteresis of supply voltage	between $V_{startup}$ and V_{stop}	8.5	9.1	9.7	V
$V_{ovp(VCC)}$	overvoltage protection voltage on pin VCC		28	30	32	V
I_{CC}	supply current	pin DRAIN; $V_{CC} < 4\text{ V};$ standby mode	-	0.1	0.2	mA
		pin DRAIN; $4\text{ V} < V_{CC} < V_{CC(low)};$ standby mode	1	1.25	1.5	mA
		pin DRAIN; $V_{CC} > V_{CC(low)};$ standby mode	-	0.2	-	mA
		pin VCC; normal operation, excluding drive currents to PWRDRV	-	2.25	-	mA
Current regulator and protection						
f_{sw}	switching frequency	low-frequency mode; undimmed				
		50 Hz mains	55	60	65	kHz
		60 Hz mains	66	72	78	kHz
		high-frequency mode; undimmed				
$V_{th(high)ISNS}$	high threshold voltage on pin ISNS	at peak current	1.195	1.24	1.285	V
		(eco-)LTHD mode; at peak current	0.75	0.78	0.81	V
$V_{th(low)ISNS}$	low threshold voltage on pin ISNS	low-ripple mode	0.33	0.35	0.37	V
			-	600	-	ns
t_{leb}	leading edge blanking time		-	600	-	ns

Table 7. Characteristics ...continued

Symbol	Parameter	Conditions	Min	Typ	Max	Unit
Valley detection						
$(\Delta V/\Delta t)_{vrec}$	valley recognition voltage change with time negative slope	voltage ringing on pin DRAIN	-26	-16	-6	V/ μ s
$t_{d(vrec-swon)}$	valley recognition to switch-on delay time		-	100	-	ns
Brownout protection						
$t_{on(high)}$	high on-time	low-frequency mode				
		50 Hz mains	13.2	14.4	15.6	μ s
		60 Hz mains	11.0	12.0	13.0	μ s
		high-frequency mode				
		50 Hz mains	8.8	9.6	10.4	μ s
		60 Hz mains	8.3	9.0	9.7	μ s
Output short protection						
$t_{off(high)}$	high off-time		32	40	48	μ s
$t_{det(sc)}$	short-circuit detection time	50 Hz mains	10	-	20	ms
		60 Hz mains	8.3	-	16.7	ms
Temperature protections						
$T_{th(act)otp}$	overtemperature protection activation threshold temperature	on-chip	160	175	190	$^{\circ}$ C
$T_{th(rel)otp}$	overtemperature protection release threshold temperature	on-chip	90	102	114	$^{\circ}$ C
Pin PWRDRV						
$V_{o(PWRDRV)}$	output voltage on pin PWRDRV	high level				
		$V_{VCC} > V_{CC(low)}$	-	10.7	-	V
		$V_{VCC} = V_{CC(stop)}$	-	8.5	-	V
$I_{source(PWRDRV)}$	source current on pin PWRDRV	20 μ s maximum; $V_{PWRDRV} = 2$ V	-	360	-	mA
$I_{sink(PWRDRV)}$	sink current on pin PWRDRV	20 μ s maximum; $V_{PWRDRV} = 10$ V	-	900	-	mA
		20 μ s maximum; $V_{PWRDRV} = 2$ V	-	260	-	mA
Pin DIM						
$V_{ctrl(A)DIM}$	analog control voltage on pin DIM		0.1	-	1.2	V
$V_{hys(low)DIM}$	low hysteresis voltage on pin DIM	analog dimming control	-	-20	-	mV
$V_{th(L)DIM}$	LOW-level threshold voltage on pin DIM	digital dimming control	0.30	0.40	0.50	V
$V_{th(H)DIM}$	HIGH-level threshold voltage on pin DIM	digital dimming control	1.25	1.50	1.75	V
$f_{i(DIM)}$	input frequency on pin DIM	digital dimming control	0.1	-	10	kHz
$I_{offset(DIM)}$	offset current on pin DIM		-7	-11	-15	μ A

Table 7. Characteristics ...continued

Symbol	Parameter	Conditions	Min	Typ	Max	Unit
$I_{LED(low)}/I_{LED100}$	low LED current ratio	analog dimming control [2]	-	0.008	-	
		digital dimming control; $f_{i(DIM)} < 3$ kHz [2]	-	0.001	-	
		digital dimming control; 3 kHz $< f_{i(DIM)} < 10$ kHz [2]	0.001	-	0.004	
		digital dimming control; $f_{i(DIM)} = 10$ kHz [2]	-	0.004	-	
$t_{det(stb)DIM}$	standby detection time on pin DIM	digital dimming control	-	10	-	ms
Pin RMAINS						
$I_{i(RMAINS)}$	input current on pin RMAINS	at top of mains sine wave	324	360	396	μ A
		for zero cross detection	18	22.5	27	μ A
$t_{d(mld)}$	mains loss detection delay time	50 Hz mains	-	60	-	ms
		60 Hz mains	-	50	-	ms
$I_{sink(RMAINS)}$	sink current on pin RMAINS	$V_{i(RMAINS)} = 4$ V	400	-	-	μ A

[1] The peak voltage on pin DRAIN occurs each switching cycle, based 25,000 hours device lifetime.

[2] Actual LED current values are lower due to the IC supply current.

12. Application information

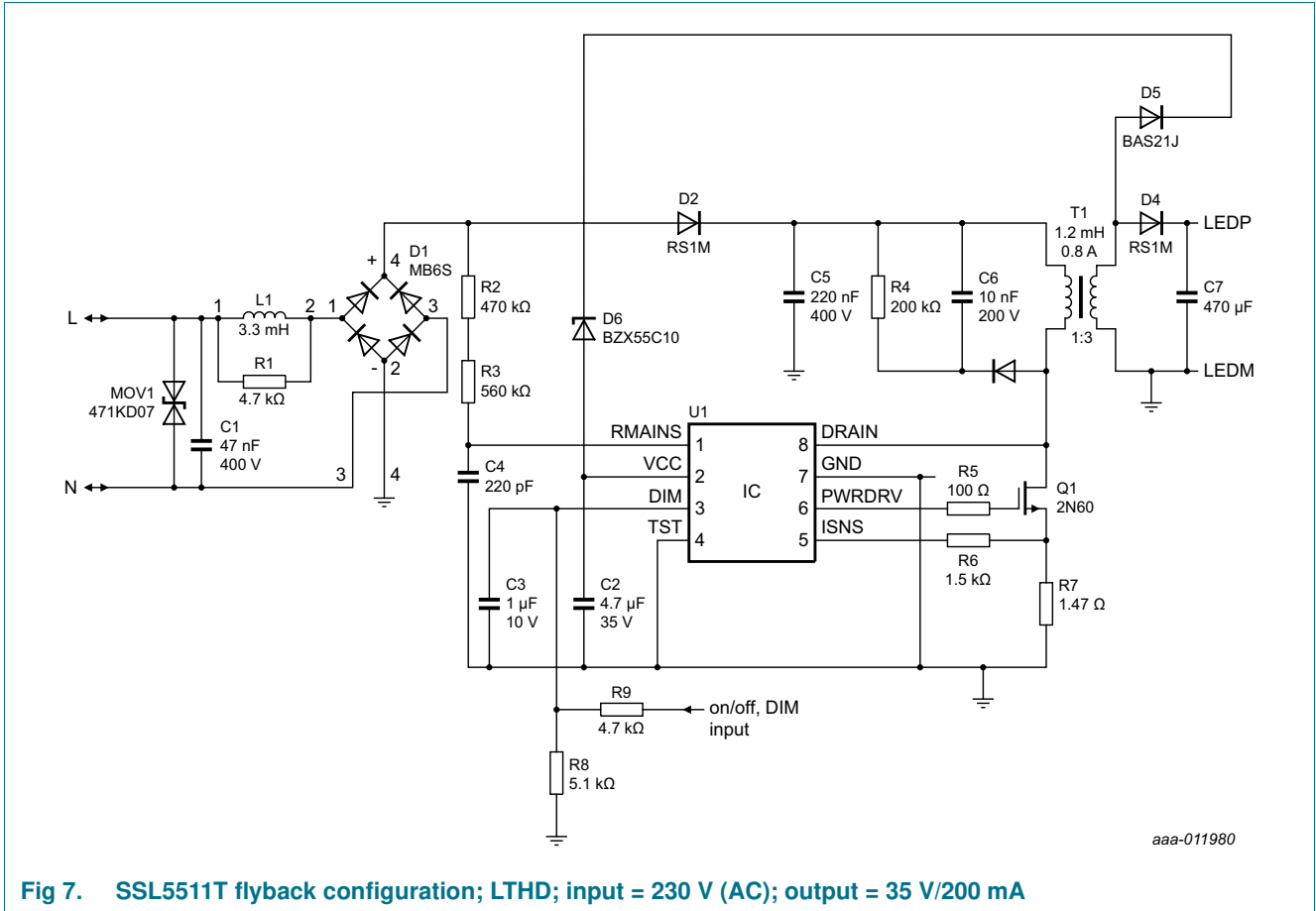

Fig 7. SSL5511T flyback configuration; LTHD; input = 230 V (AC); output = 35 V/200 mA

13. Package outline

SO8: plastic small outline package; 8 leads; body width 3.9 mm

SOT96-1

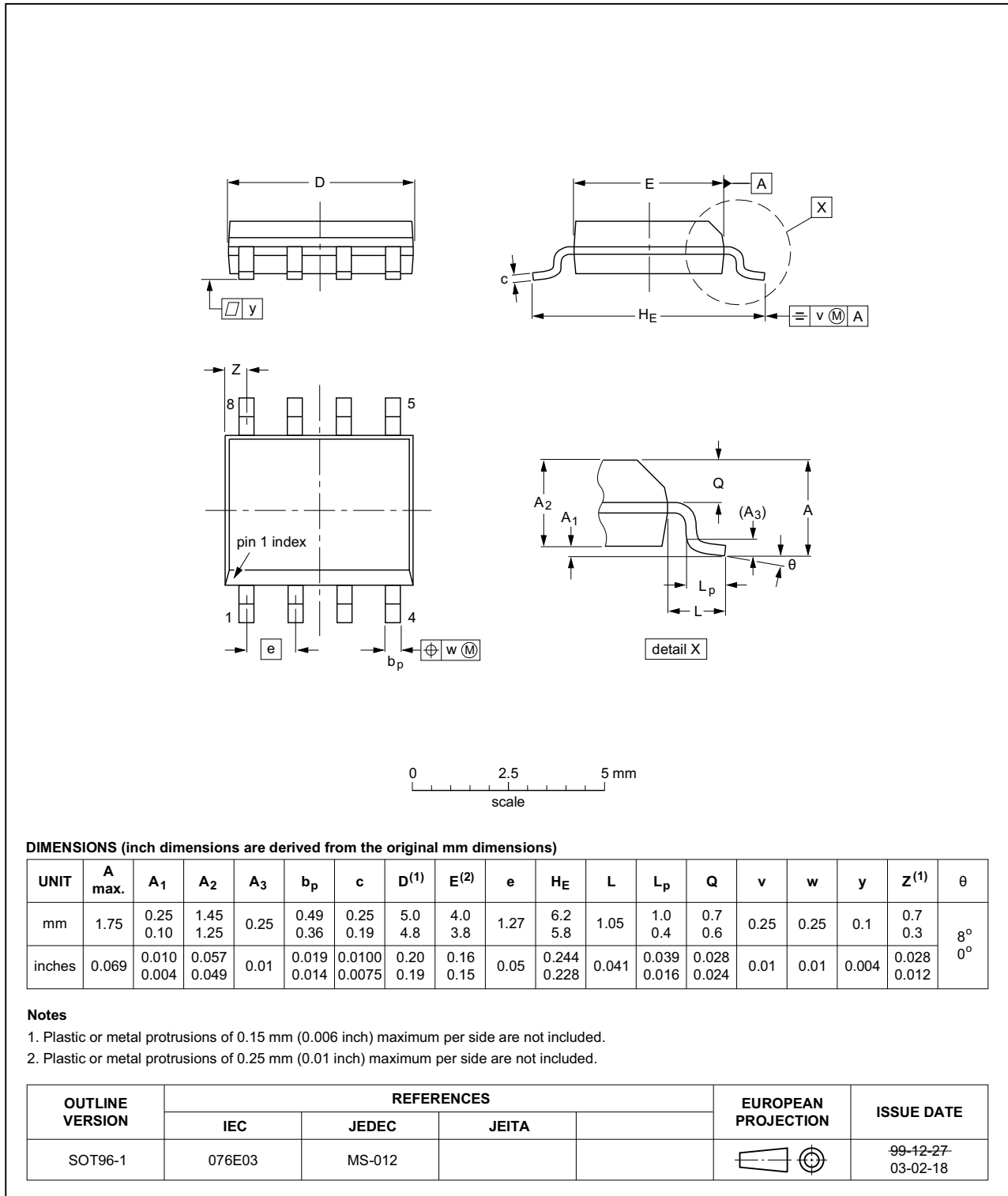

Fig 8. Package outline SOT96-1 (SO8)

14. Revision history

Table 8. Revision history

Document ID	Release date	Data sheet status	Change notice	Supersedes
SSL5511T v.2	20140630	Product data sheet	-	SSL5511T v.1
Modifications:	<ul style="list-style-type: none">• Data sheet status has changed from Preliminary to Product.• Text and graphics updated throughout the document.			
SSL5511T v.1	20140527	Preliminary data sheet	-	-

15. Legal information

15.1 Data sheet status

Document status ^{[1][2]}	Product status ^[3]	Definition
Objective [short] data sheet	Development	This document contains data from the objective specification for product development.
Preliminary [short] data sheet	Qualification	This document contains data from the preliminary specification.
Product [short] data sheet	Production	This document contains the product specification.

[1] Please consult the most recently issued document before initiating or completing a design.

[2] The term 'short data sheet' is explained in section "Definitions".

[3] The product status of device(s) described in this document may have changed since this document was published and may differ in case of multiple devices. The latest product status information is available on the Internet at URL <http://www.nxp.com>.

15.2 Definitions

Draft — The document is a draft version only. The content is still under internal review and subject to formal approval, which may result in modifications or additions. NXP Semiconductors does not give any representations or warranties as to the accuracy or completeness of information included herein and shall have no liability for the consequences of use of such information.

Short data sheet — A short data sheet is an extract from a full data sheet with the same product type number(s) and title. A short data sheet is intended for quick reference only and should not be relied upon to contain detailed and full information. For detailed and full information see the relevant full data sheet, which is available on request via the local NXP Semiconductors sales office. In case of any inconsistency or conflict with the short data sheet, the full data sheet shall prevail.

Product specification — The information and data provided in a Product data sheet shall define the specification of the product as agreed between NXP Semiconductors and its customer, unless NXP Semiconductors and customer have explicitly agreed otherwise in writing. In no event however, shall an agreement be valid in which the NXP Semiconductors product is deemed to offer functions and qualities beyond those described in the Product data sheet.

15.3 Disclaimers

Limited warranty and liability — Information in this document is believed to be accurate and reliable. However, NXP Semiconductors does not give any representations or warranties, expressed or implied, as to the accuracy or completeness of such information and shall have no liability for the consequences of use of such information. NXP Semiconductors takes no responsibility for the content in this document if provided by an information source outside of NXP Semiconductors.

In no event shall NXP Semiconductors be liable for any indirect, incidental, punitive, special or consequential damages (including - without limitation - lost profits, lost savings, business interruption, costs related to the removal or replacement of any products or rework charges) whether or not such damages are based on tort (including negligence), warranty, breach of contract or any other legal theory.

Notwithstanding any damages that customer might incur for any reason whatsoever, NXP Semiconductors' aggregate and cumulative liability towards customer for the products described herein shall be limited in accordance with the *Terms and conditions of commercial sale* of NXP Semiconductors.

Right to make changes — NXP Semiconductors reserves the right to make changes to information published in this document, including without limitation specifications and product descriptions, at any time and without notice. This document supersedes and replaces all information supplied prior to the publication hereof.

Suitability for use — NXP Semiconductors products are not designed, authorized or warranted to be suitable for use in life support, life-critical or safety-critical systems or equipment, nor in applications where failure or malfunction of an NXP Semiconductors product can reasonably be expected to result in personal injury, death or severe property or environmental damage. NXP Semiconductors and its suppliers accept no liability for inclusion and/or use of NXP Semiconductors products in such equipment or applications and therefore such inclusion and/or use is at the customer's own risk.

Applications — Applications that are described herein for any of these products are for illustrative purposes only. NXP Semiconductors makes no representation or warranty that such applications will be suitable for the specified use without further testing or modification.

Customers are responsible for the design and operation of their applications and products using NXP Semiconductors products, and NXP Semiconductors accepts no liability for any assistance with applications or customer product design. It is customer's sole responsibility to determine whether the NXP Semiconductors product is suitable and fit for the customer's applications and products planned, as well as for the planned application and use of customer's third party customer(s). Customers should provide appropriate design and operating safeguards to minimize the risks associated with their applications and products.

NXP Semiconductors does not accept any liability related to any default, damage, costs or problem which is based on any weakness or default in the customer's applications or products, or the application or use by customer's third party customer(s). Customer is responsible for doing all necessary testing for the customer's applications and products using NXP Semiconductors products in order to avoid a default of the applications and the products or of the application or use by customer's third party customer(s). NXP does not accept any liability in this respect.

Limiting values — Stress above one or more limiting values (as defined in the Absolute Maximum Ratings System of IEC 60134) will cause permanent damage to the device. Limiting values are stress ratings only and (proper) operation of the device at these or any other conditions above those given in the Recommended operating conditions section (if present) or the Characteristics sections of this document is not warranted. Constant or repeated exposure to limiting values will permanently and irreversibly affect the quality and reliability of the device.

Terms and conditions of commercial sale — NXP Semiconductors products are sold subject to the general terms and conditions of commercial sale, as published at <http://www.nxp.com/profile/terms>, unless otherwise agreed in a valid written individual agreement. In case an individual agreement is concluded only the terms and conditions of the respective agreement shall apply. NXP Semiconductors hereby expressly objects to applying the customer's general terms and conditions with regard to the purchase of NXP Semiconductors products by customer.

No offer to sell or license — Nothing in this document may be interpreted or construed as an offer to sell products that is open for acceptance or the grant, conveyance or implication of any license under any copyrights, patents or other industrial or intellectual property rights.

Export control — This document as well as the item(s) described herein may be subject to export control regulations. Export might require a prior authorization from competent authorities.

Quick reference data — The Quick reference data is an extract of the product data given in the Limiting values and Characteristics sections of this document, and as such is not complete, exhaustive or legally binding.

Non-automotive qualified products — Unless this data sheet expressly states that this specific NXP Semiconductors product is automotive qualified, the product is not suitable for automotive use. It is neither qualified nor tested in accordance with automotive testing or application requirements. NXP Semiconductors accepts no liability for inclusion and/or use of non-automotive qualified products in automotive equipment or applications.

In the event that customer uses the product for design-in and use in automotive applications to automotive specifications and standards, customer (a) shall use the product without NXP Semiconductors' warranty of the product for such automotive applications, use and specifications, and (b)

whenever customer uses the product for automotive applications beyond NXP Semiconductors' specifications such use shall be solely at customer's own risk, and (c) customer fully indemnifies NXP Semiconductors for any liability, damages or failed product claims resulting from customer design and use of the product for automotive applications beyond NXP Semiconductors' standard warranty and NXP Semiconductors' product specifications.

Translations — A non-English (translated) version of a document is for reference only. The English version shall prevail in case of any discrepancy between the translated and English versions.

15.4 Trademarks

Notice: All referenced brands, product names, service names and trademarks are the property of their respective owners.

GreenChip — is a trademark of NXP Semiconductors N.V.

16. Contact information

For more information, please visit: <http://www.nxp.com>

For sales office addresses, please send an email to: salesaddresses@nxp.com

17. Contents

1	General description	1	16	Contact information	21
2	Features and benefits	2	17	Contents	22
3	Applications	2			
4	Quick reference data	3			
5	Ordering information	3			
6	Block diagram	4			
7	Pinning information	4			
7.1	Pinning	4			
7.2	Pin description	5			
8	Functional description	5			
8.1	Pin functionality	5			
8.1.1	Pin RMAINS	5			
8.1.2	Pin VCC	5			
8.1.3	Pin DIM	5			
8.1.4	Pin ISNS	6			
8.1.5	Pin PWRDRV	6			
8.1.6	Pin DRAIN	6			
8.2	Converter operation	6			
8.2.1	Available modes	6			
8.2.2	Switching scheme	7			
8.2.3	Valley detection	7			
8.2.4	Output current settings	8			
8.2.5	Preventing Continuous Conduction Mode (CCM)	9			
8.2.6	Dimming support	9			
8.3	Protections	11			
8.3.1	UnderVoltage LockOut (UVLO)	11			
8.3.2	OverCurrent Protection (OCP)	11			
8.3.3	Brownout protection	11			
8.3.4	Output short protection (OSP)	11			
8.3.5	Output open OverVoltage Protection (OVP) ..	11			
8.3.6	Internal OverTemperature Protection (OTP) ..	12			
8.3.7	Mains synchronization loss protection	12			
8.3.8	Leading Edge Blanking (LEB)	12			
9	Limiting values	13			
10	Thermal characteristics	13			
11	Characteristics	14			
12	Application information	17			
13	Package outline	18			
14	Revision history	19			
15	Legal information	20			
15.1	Data sheet status	20			
15.2	Definitions	20			
15.3	Disclaimers	20			
15.4	Trademarks	21			

Please be aware that important notices concerning this document and the product(s) described herein, have been included in section 'Legal information'.

© NXP Semiconductors N.V. 2014.

All rights reserved.

For more information, please visit: <http://www.nxp.com>

For sales office addresses, please send an email to: salesaddresses@nxp.com

Date of release: 30 June 2014

Document identifier: SSL5511T