



Chipsmall Limited consists of a professional team with an average of over 10 year of expertise in the distribution of electronic components. Based in Hongkong, we have already established firm and mutual-benefit business relationships with customers from,Europe,America and south Asia,supplying obsolete and hard-to-find components to meet their specific needs.

With the principle of "Quality Parts,Customers Priority,Honest Operation,and Considerate Service",our business mainly focus on the distribution of electronic components. Line cards we deal with include Microchip,ALPS,ROHM,Xilinx,Pulse,ON,Everlight and Freescale. Main products comprise IC,Modules,Potentiometer,IC Socket,Relay,Connector.Our parts cover such applications as commercial,industrial, and automotives areas.

We are looking forward to setting up business relationship with you and hope to provide you with the best service and solution. Let us make a better world for our industry!



Contact us

Tel: +86-755-8981 8866 Fax: +86-755-8427 6832

Email & Skype: info@chipsmall.com Web: www.chipsmall.com

Address: A1208, Overseas Decoration Building, #122 Zhenhua RD., Futian, Shenzhen, China



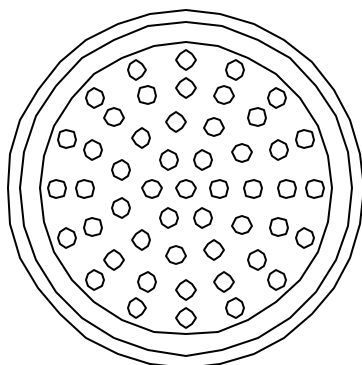
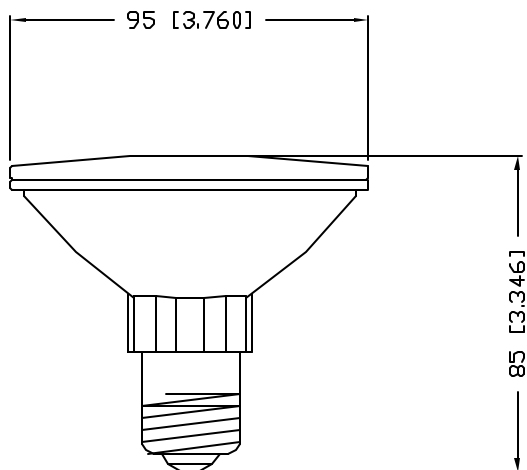

ELECTRO-OPTICAL CHARACTERISTICS $T_A=25^{\circ}\text{C}$ $V_f=120\text{VAC}$

| PARAMETER | MIN | TYP | MAX | UNITS |
|--------------------------|-------------|-----|-----|--------------------|
| PEAK WAVELENGTH | | 470 | | nm |
| FORWARD VOLTAGE | | 120 | | VAC |
| POWER DISSIPATION | | 2.4 | | W |
| LUMINOUS FLUX | | 15 | | lm |
| VIEWING ANGLE | | 15 | | 2x theta |
| OPERATING, STORAGE TEMP. | -20 | | +70 | $^{\circ}\text{C}$ |
| EMITTED COLOR: | BLUE | | | |
| EPOXY LENS FINISH: | WATER CLEAR | | | |

*UNLESS OTHERWISE SPECIFIED TOLERANCES PER DECIMAL PRECISION ARE: X=±1 (±0.039), X.X=±0.5 (±0.020), X.XX=±0.25 (±0.010), X.XXX=±0.127 (±0.005). LEAD SIZE=±0.05 (±0.002), LEAD LENGTH=±0.75 (±0.030). MIN= +DECIMAL PRECISION -0.00 MAX= +0.00 -DECIMAL PRECISION

| | | | | |
|--|---------------------------------|---|---|---|
| REV. | PART NUMBER SSP-50PAR307U110 | CONFIDENTIAL INFORMATION THE INFORMATION CONTAINED IN THIS DOCUMENT IS THE PROPERTY OF SUNBRITE LEDS. EXCEPT AS SPECIFICALLY AUTHORIZED IN WRITING BY SUNBRITE LEDS, THE HOLDER OF THIS DOCUMENT SHALL KEEP ALL INFORMATION CONTAINED HEREIN CONFIDENTIAL AND SHALL PROTECT SAME IN WHOLE OR IN PART FROM DISCLOSURE AND DISSEMINATION TO ALL THIRD PARTIES. |  | 286 E. HELEN ROAD PALATINE, IL 60067-6976 PHONE: +1.847.348.3116 FAX: +1.847.359.2867 WEB: www.sunbriteleds.com |
| 50 LED, PAR 30, REPLACEMENT LAMP, 470nm BLUE LED, WATER CLEAR LENS. | | RELIABILITY NOTE OUR MANY YEARS OF EXPERIENCE DATA ACCUMULATION INDICATE THAT SOLDER HEAT IS A MAJOR CAUSE OF EARLY AND FUTURE FAILURE. PLEASE PAY ATTENTION TO YOUR SOLDERING PROCESS. | DRAWN: JD | CHECKED: APPROVED: DATE: 7.28.04 PAGE: 1 OF 1 |