



Chipsmall Limited consists of a professional team with an average of over 10 year of expertise in the distribution of electronic components. Based in Hongkong, we have already established firm and mutual-benefit business relationships with customers from,Europe,America and south Asia,supplying obsolete and hard-to-find components to meet their specific needs.

With the principle of “Quality Parts,Customers Priority,Honest Operation,and Considerate Service”,our business mainly focus on the distribution of electronic components. Line cards we deal with include Microchip,ALPS,ROHM,Xilinx,Pulse,ON,Everlight and Freescale. Main products comprise IC,Modules,Potentiometer,IC Socket,Relay,Connector.Our parts cover such applications as commercial,industrial, and automotives areas.

We are looking forward to setting up business relationship with you and hope to provide you with the best service and solution. Let us make a better world for our industry!



Contact us

Tel: +86-755-8981 8866 Fax: +86-755-8427 6832

Email & Skype: info@chipsmall.com Web: www.chipsmall.com

Address: A1208, Overseas Decoration Building, #122 Zhenhua RD., Futian, Shenzhen, China





The SST12LF01 is a 2.4 GHz Front-End Module (FEM) that combines a high-performance Low-Noise Amplifier (LNA) and a Power Amplifier (PA). Designed in compliance with IEEE 802.11 b/g/n applications and based on GaAs PHEMT/HBT technology, the SST12LF01 operates within the frequency range of 2.4- 2.55 GHz at a very low DC-current consumption. The Transmitter chain has excellent linearity, typically <3% added EVM up to 19 dBm output power, which is essential for 54 Mbps 802.11g operation while meeting 802.11g spectrum mask at 23 dBm. The SST12LF01 is offered in a 24-contact WQFN package.

Features

- **Gain:**
 - Typically 12 dB gain across 2.4–2.5 GHz for Receiver (RX) chain.
 - Typically 29 dB gain across 2.4–2.5 GHz over temperature 0°C to +80°C for Transmitter (TX) chain.
- **Low-Noise Figure**
 - Typical 1.45 dB across 2.4–2.55 GHz
- **50 Ω Input/Output matched along RX chain.**
- **Rx IIP3**
 - >1 dbm across 2.4–2.55 GHz
- **High linear output power:**
 - >26.5 dBm P1dB
 - Meets 802.11g OFDM ACPR requirement up to 23 dBm
 - ~3% added EVM up to 19 dBm for 54 Mbps 802.11g signal
 - Meets 802.11b ACPR requirement up to 24 dBm
- **High power-added efficiency/Low operating current for both 802.11g/b applications**
 - ~22%/210 mA @ P_{OUT} = 22 dBm for 802.11g
 - ~26%/240 mA @ P_{OUT} = 23.5 dBm for 802.11b
- **Low idle current**
 - ~70 mA I_{CO}
- **Low shut-down current (Typical 2.5 μA)**
- **Built-in, Ultra-low I_{REF} power-up/down control**
 - I_{REF} <4 mA
- **High-speed power-up/down**
 - Turn on/off time (10%- 90%) <100 ns
 - Typical power-up/down delay with driver delay included <200 ns
- **High temperature stability**
 - ~1 dB gain/power variation between 0°C to +85°C
- **Simple input/output matching**
- **Single positive power supply**
- **Packages available**
 - 24-contact WQFN – 4mm x 4mm
- **All devices are RoHS compliant**

Applications

- WLAN
- Bluetooth
- Wireless Network



Product Description

The SST12LF01 is a 2.4 GHz Front-End Module (FEM) that combines a high-performance Low-Noise Amplifier (LNA) and a Power Amplifier (PA).

Designed in compliance with IEEE 802.11 b/g/n applications and based on GaAs PHEMT/HBT technology, the SST12LF01 operates within the frequency range of 2.4–2.55 GHz at a very low DC-current consumption. There are two components to the FEM: the Receiver (RX) chain and the Transmitter (TX) chain.

The RX chain consist of a cost effective Low-Noise Amplifier (LNA) cell which requires no external RF-matching components. This device is based on the 0.5m GaAs PHEMT technology, and complies with 802.11 b/g/n applications.

The LNA provides high-performance, low-noise, and moderate gain operation within the 2.4–2.55 GHz frequency band. Across this frequency band, the LNA typically provides 12 dB gain and 1.45 dB noise figure.

This LNA cell is designed with a self DC-biasing scheme, which maintains low DC current consumption, nominally at 11 mA, during operation. Optimum performance is achieved with only a single power supply and no external bias resistors or networks are required. The input and output ports are singled-ended 50 Ohm matched. RF ports are also DC isolated requiring no dc blocking capacitors or matching components to reduce system board Bill of Materials (BOM) cost.

The TX chain includes a high-efficiency PA based on InGaP/GaAs HBT technology. The PA typically provides 30 dB gain with 22% power-added efficiency at $P_{OUT} = 22$ dBm for 802.11g and 27% power-added efficiency at $P_{OUT} = 24$ dBm for 802.11b.

The Transmitter chain has excellent linearity, typically <4% added EVM up to 20 dBm output power, which is essential for 54 Mbps 802.11g operation while meeting 802.11g spectrum mask at 23 dBm.

The SST12LF01 is offered in 24-contact WQFN package. See Figure 2 for pin assignments and Table 1 for pin descriptions.



Functional Blocks

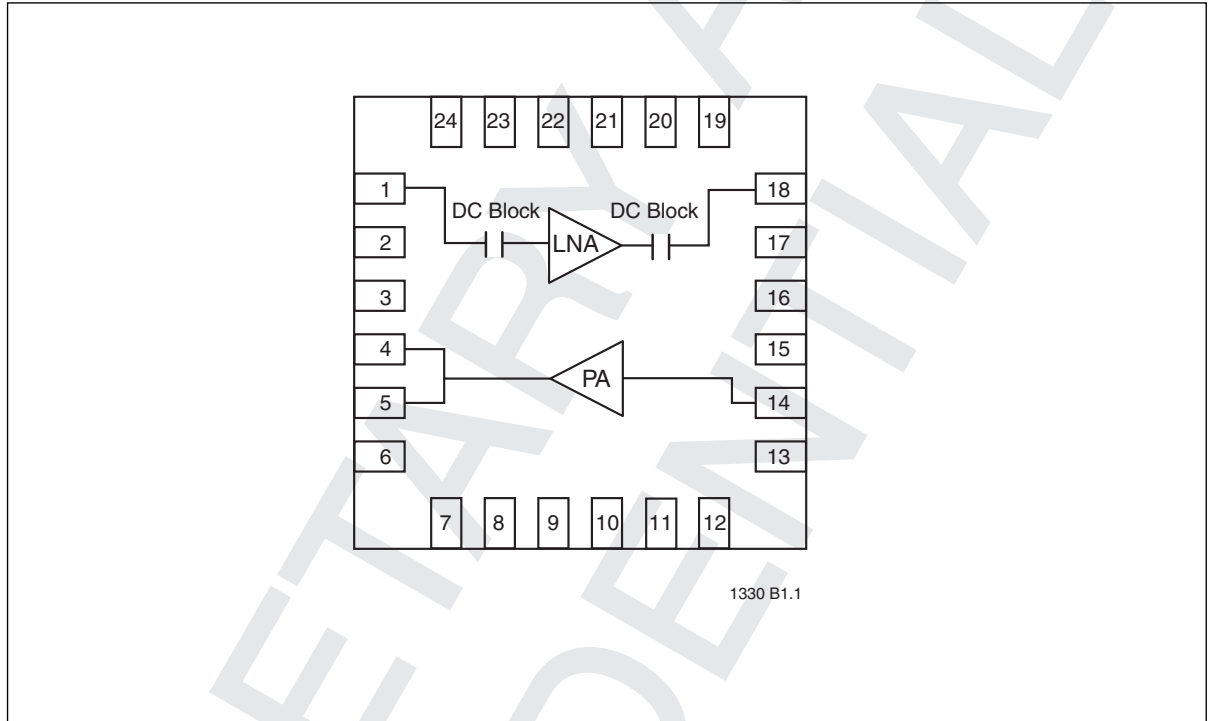

Figure 1: Functional Block Diagram



Pin Assignments

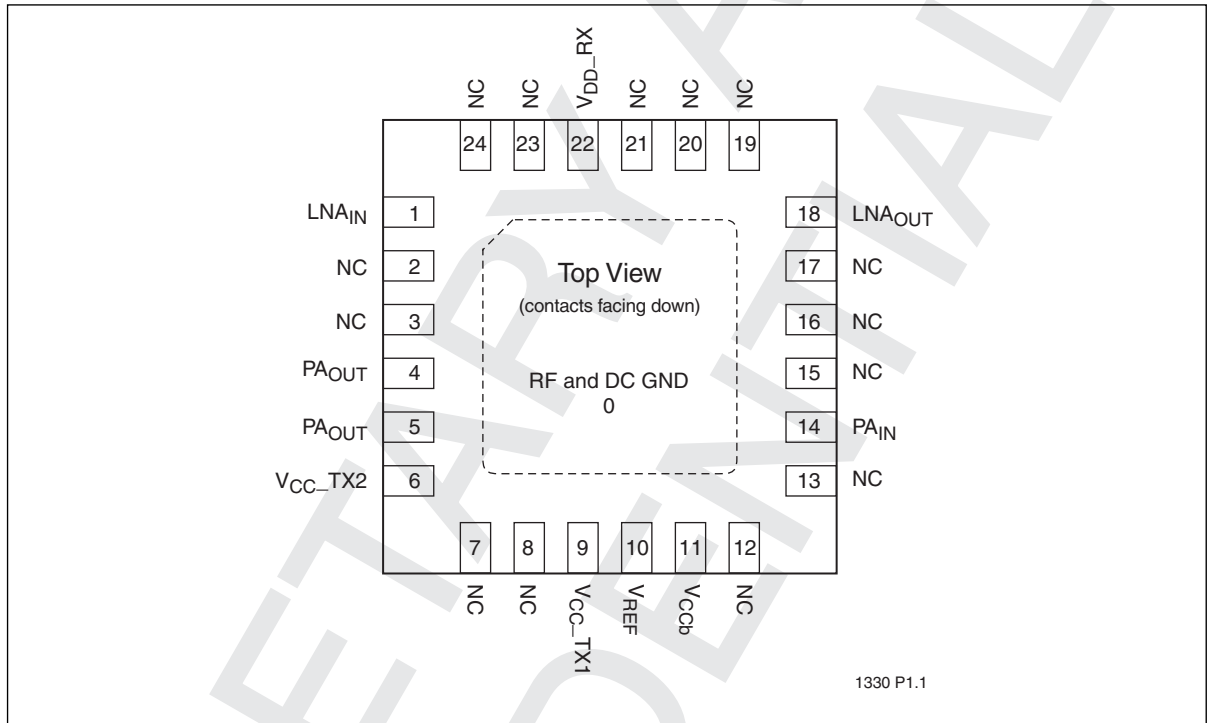

Figure 2: Pin Assignments for 24-contact WQFN



Pin Descriptions

Table 1: Pin Description

Symbol	Pin No.	Pin Name	Type ¹	Function
LNA _{IN}	1		I	LNA RF Input
NC	2	No Connection		Unconnected pin
NC	3	No Connection		Unconnected pin
PA _{OUT}	4		O	PA RF output
PA _{OUT}	5		O	PA RF output
V _{CC_TX2}	6	Power Supply	PWR	PA power supply, 2 nd stage
NC	7	No Connection		Unconnected pin
NC	8	No Connection		Unconnected pin
V _{CC_TX1}	9	Power Supply	PWR	PA power supply, 1 st stage
V _{REF}	10		PWR	PA-enable and current control
V _{CCb}	11	Power Supply	PWR	PA power supply, bias circuit
NC	12	No Connection		Unconnected pin
NC	13	No Connection		Unconnected pin
PA _{IN}	14		I	PA RF input
NC	15	No Connection		Unconnected pin
NC	16	No Connection		Unconnected pin
NC	17	No Connection		Unconnected pin
LNA _{OUT}	18		O	LNA RF Output
NC	19	No Connection		Unconnected pin
NC	20	No Connection		Unconnected pin
NC	21	No Connection		Unconnected pin
V _{DD_RX}	22	Power Supply	PWR	LNA power supply
NC	23	No Connection		Unconnected pin
NC	24	No Connection		Unconnected pin

1. I=Input, O=Output

T1.0 75040



Electrical Specifications

The AC and DC specifications for the power amplifier interface signals. Refer to Table 3 for the DC voltage and current specifications. Refer to Figures 3 through 14 for the RF performance.

Absolute Maximum Stress Ratings (Applied conditions greater than those listed under “Absolute Maximum Stress Ratings” may cause permanent damage to the device. This is a stress rating only and functional operation of the device at these conditions or conditions greater than those defined in the operational sections of this data sheet is not implied. Exposure to absolute maximum stress rating conditions may affect device reliability.)

Input power to pins 1 (LNA)	0 dBm
Input power to pins 14 (PA)	-5 dBm
Average output power pins 4 and 5 (P _{OUT}) ¹	24 dBm
Average output power pin 18 (P _{OUT}) ¹	9 dBm
Supply Voltage at pins 6, 9, and 11 (V _{CC})	-0.3V to +4.6V
Supply Voltage at pin 22 (V _{DD})	-0.3V to +4.6V
Reference voltage to pin 10 (V _{REF})	-0.3V to +3.6V
DC supply current to pin 10 (I _{DD})	14 mA
DC supply current to pin 6, 9, and 11 (I _{CC})	300 mA
Operating Temperature (T _A)	-40°C to +85°C
Storage Temperature (T _{STG})	-40°C to +120°C
Maximum Junction Temperature (T _J)	+150°C
Surface Mount Solder Reflow Temperature	260°C for 10 seconds

1. Never measure with CW source. Pulsed single-tone source with <50% duty cycle is recommended. Exceeding the maximum rating of average output power could cause permanent damage to the device.

Table 2: Operating Range

Range	Ambient Temp	V _{CC} / V _{DD}
Commercial	-0 to 80°C	2.9–4.2V

T2.1 75040

Table 3: DC Electrical Characteristics

Symbol	Parameter	Min.	Typ	Max.	Unit
V _{CC}	Supply Voltage at pins 6, 9, 11, and 22		3.3	4.2	V
I _{CC}	Supply Current at pin 22		10		mA
	for 802.11g, 22 dBm at pins 6, 9, and 11		210		mA
	for 802.11b, 23.5 dBm at pins 6, 9, and 11		260		mA
I _{CQ}	Idle current for 802.11g to meet EVM<4% @ 20 dBm		75		mA
I _{OFF}	Shut down current		2.5		µA
V _{REF} ¹	Reference Voltage at pin10 with R _{REG} = 0Ω resistor		2.7		V
	Reference Voltage at pin 10 with R _{REG} = 120Ω resistor	2.7	2.9	3.1	V
	Reference Voltage at pin 10 with R _{REG} = 220Ω resistor	2.9	3.1	3.3	V

T3.1 75040

1. V_{REF} and V_{REG} are defined in Figure 15. Three combinations of resistor values and applied voltages of V_{REG} are suggested in Table 3.



Table 4: AC Electrical Characteristics for RX Chain

Symbol	Parameter	Min.	Typ	Max.	Unit
F _{L-U}	Frequency range	2400		2550	MHz
G	Small signal gain	10	12		dB
NF	Noise Figure		1.45		dB
IIP3	2.4–2.55 GHz	1	3		dBm

T4.1 75040

Table 5: AC Electrical Characteristics for TX Chain

Symbol	Parameter	Min.	Typ	Max.	Unit
F _{L-U}	Frequency range	2400		2485	MHz
P _{OUT}	Output power @ PIN = -6 dBm 11b signals	23			dBm
	@ PIN = -9 dBm 11g signals	20			dBm
G	Small signal gain	28	29	33	dB
G _{VAR1}	Gain variation over band (2400~2485 MHz)			±0.5	dB
G _{VAR2}	Gain ripple over channel (20 MHz)		0.2		dB
ACPR	Meet 11b spectrum mask	23			dBm
	Meet 11g OFDM 54 Mbps spectrum mask	22			dBm
Added EVM	@ 20 dBm output with 11g OFDM 54 Mbps signal		4		%
2f, 3f, 4f, 5f	Harmonics at 22 dBm, without external filters			-40	dBc

T5.1 75040



Typical Performance Characteristics

Test Conditions: $V_{DD} = 3.0V$, $T_A = 25^\circ C$, unless otherwise specified

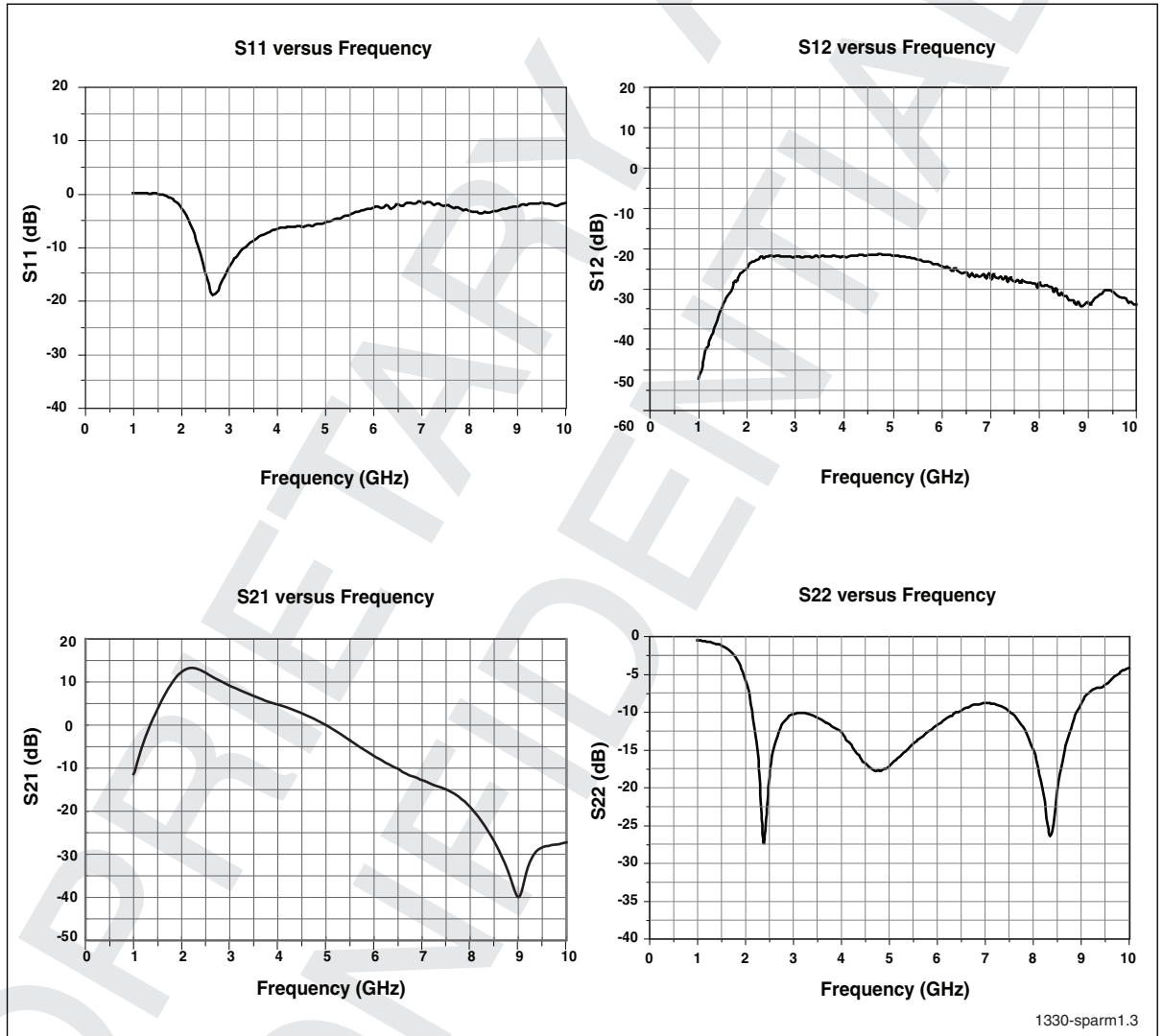

Figure 3: S-Parameters, RX Chain

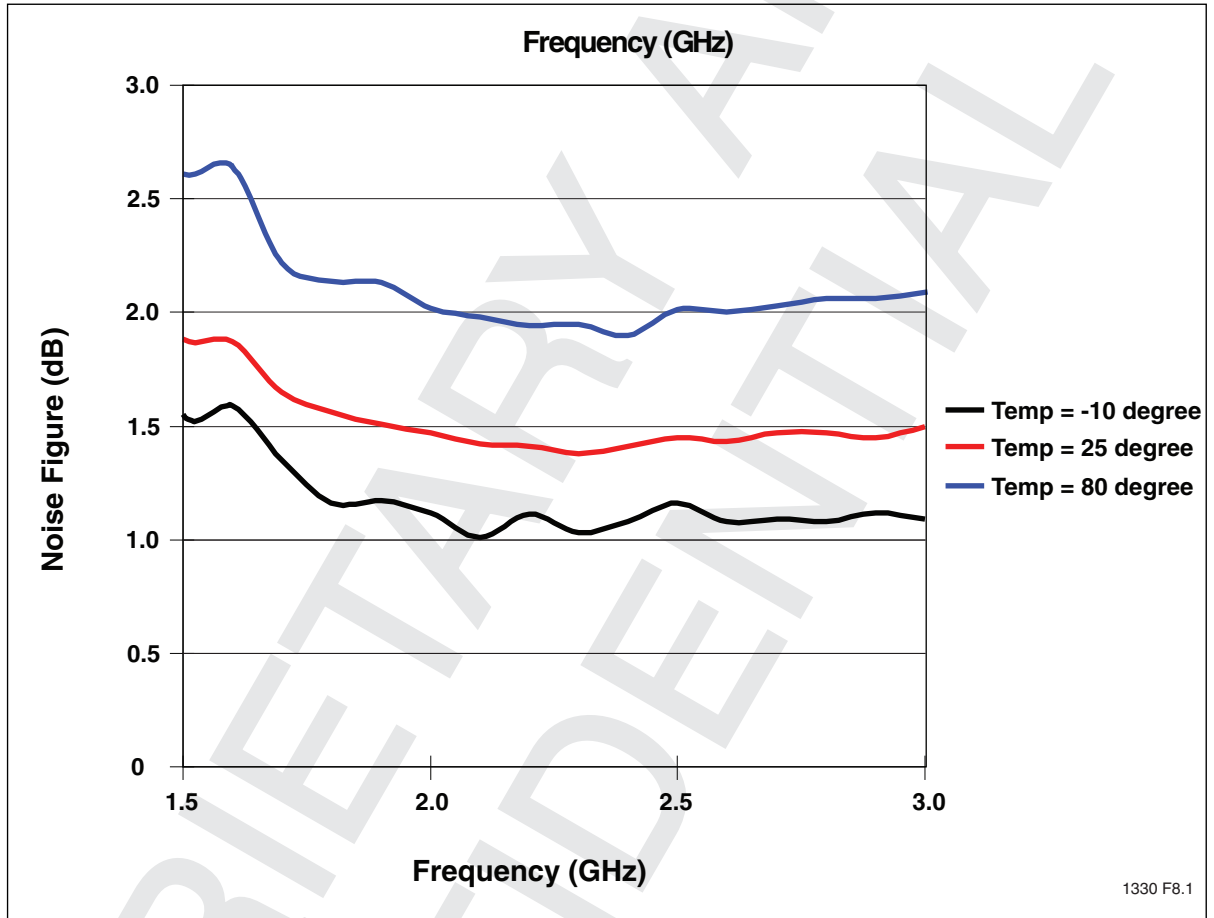

Figure 4: Noise Figure versus Frequency, RX Chain

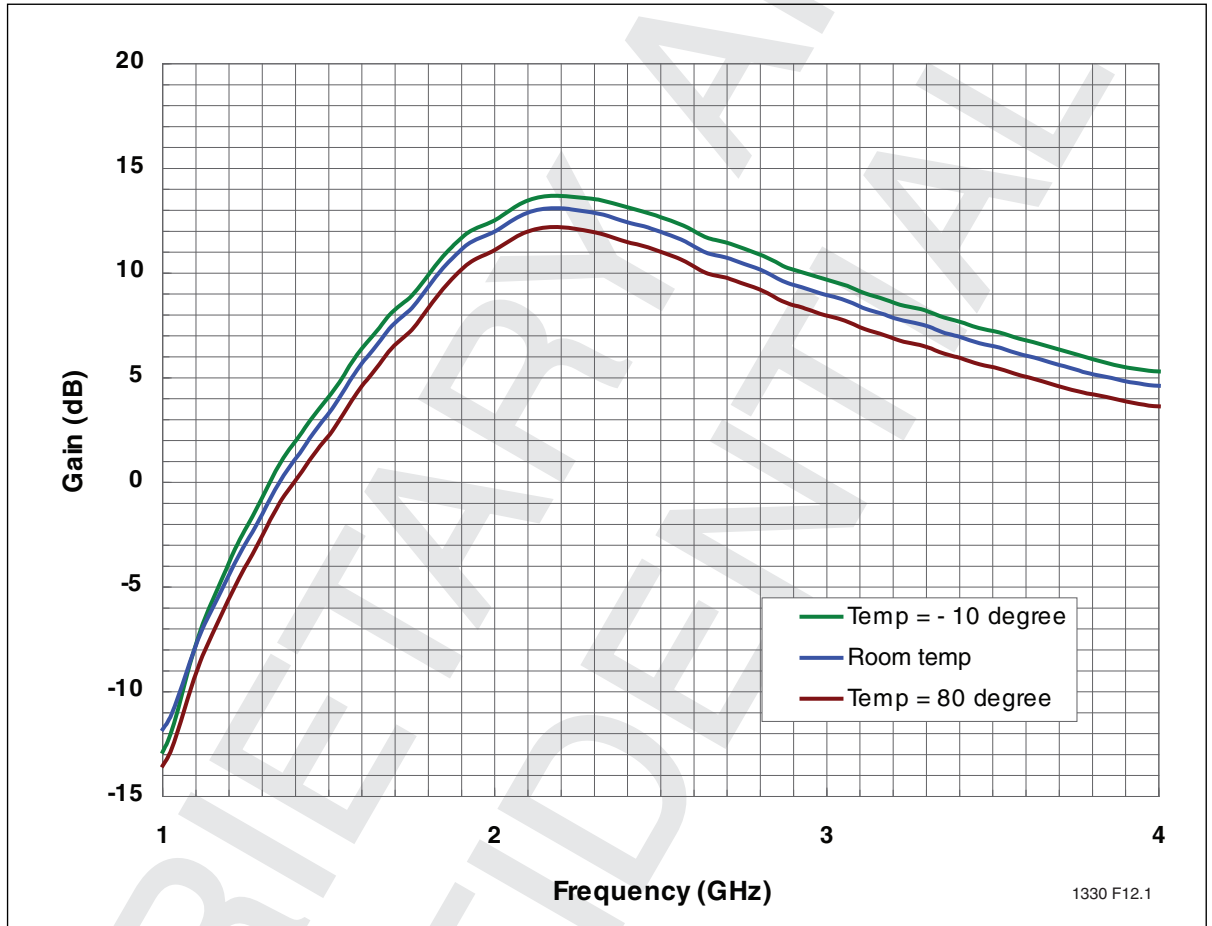

Figure 5: Frequency Response of Gain (S21) over three Temperatures

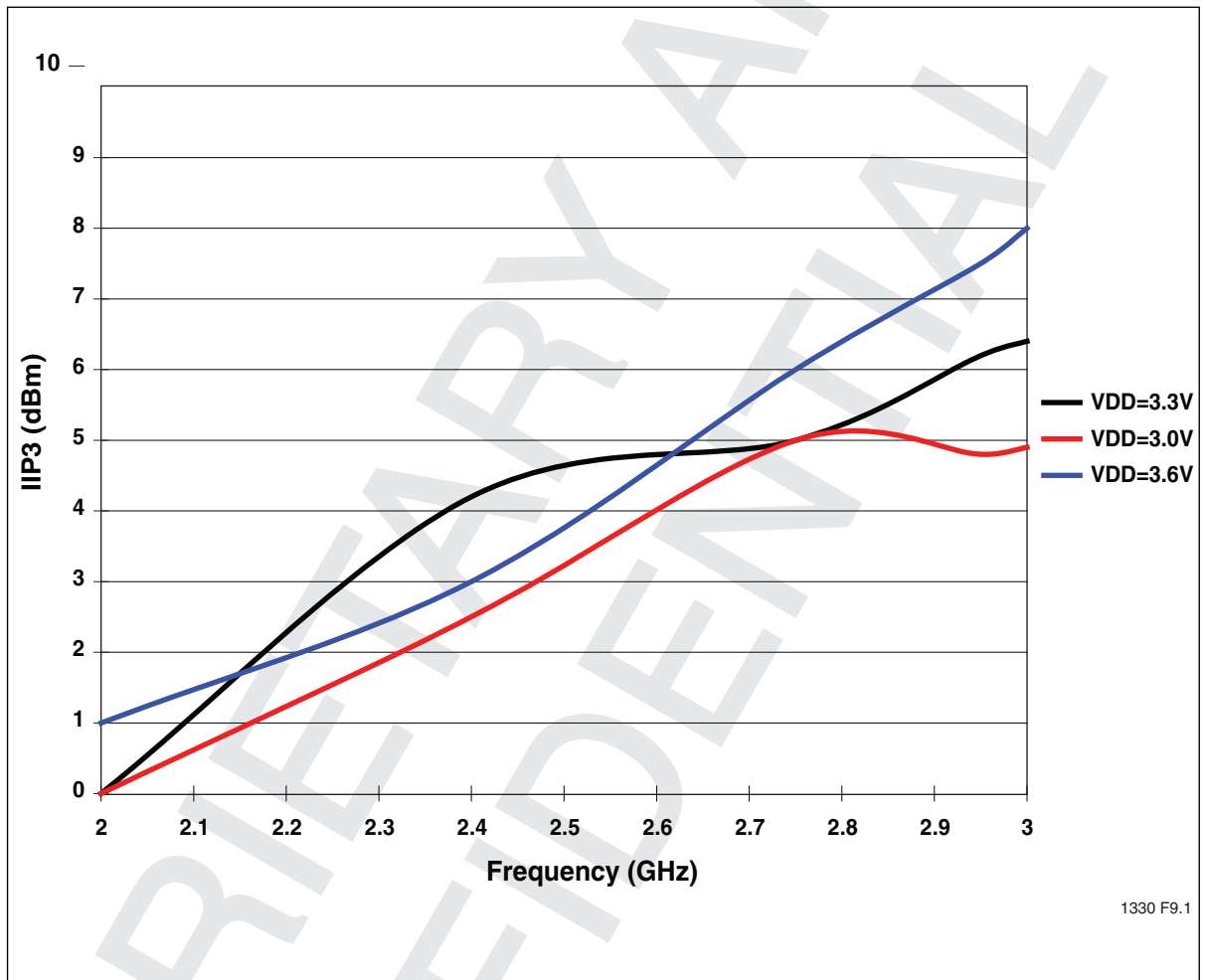

Figure 6: Input IP3 versus Frequency, RX Chain

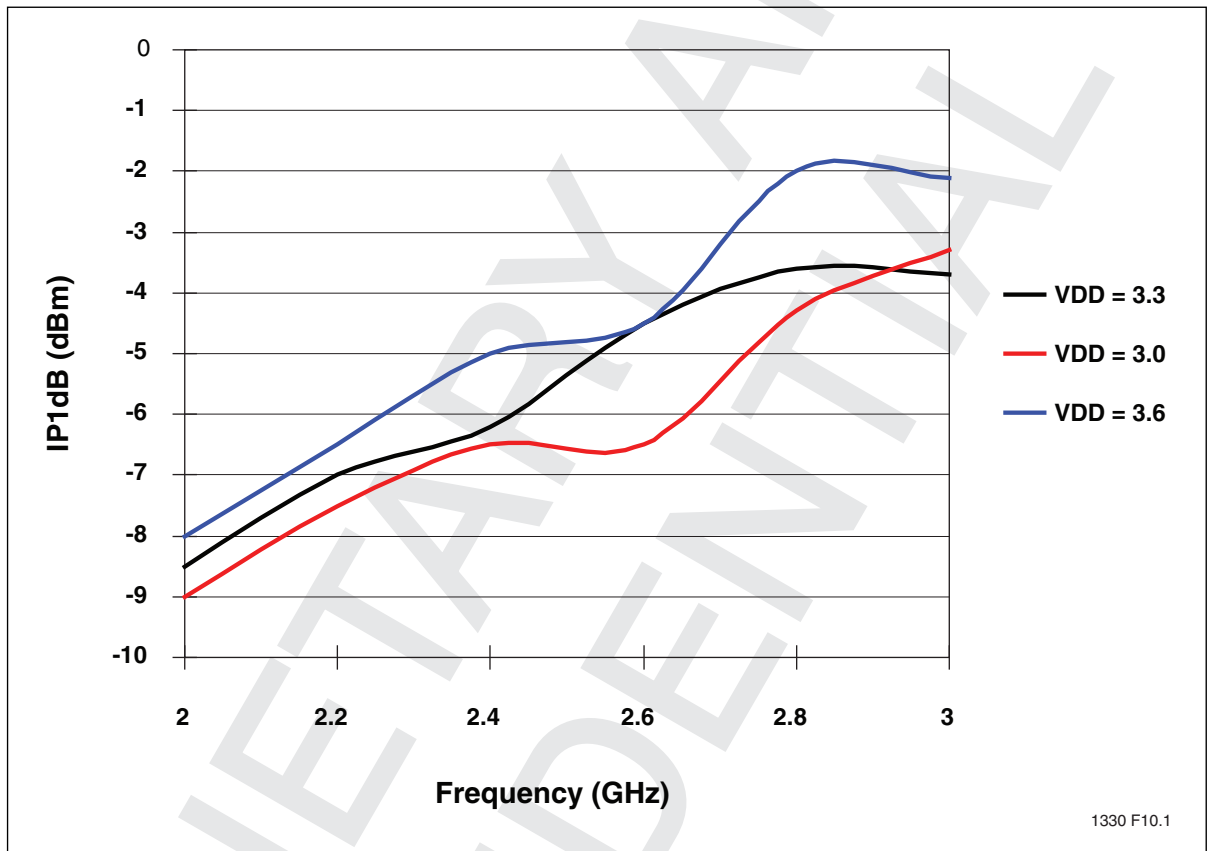

Figure 7: Input P1dB versus Frequency, RX Chain



Test Conditions: $V_{CC} = 3.3V$, $T_A = 25^\circ C$, unless otherwise specified

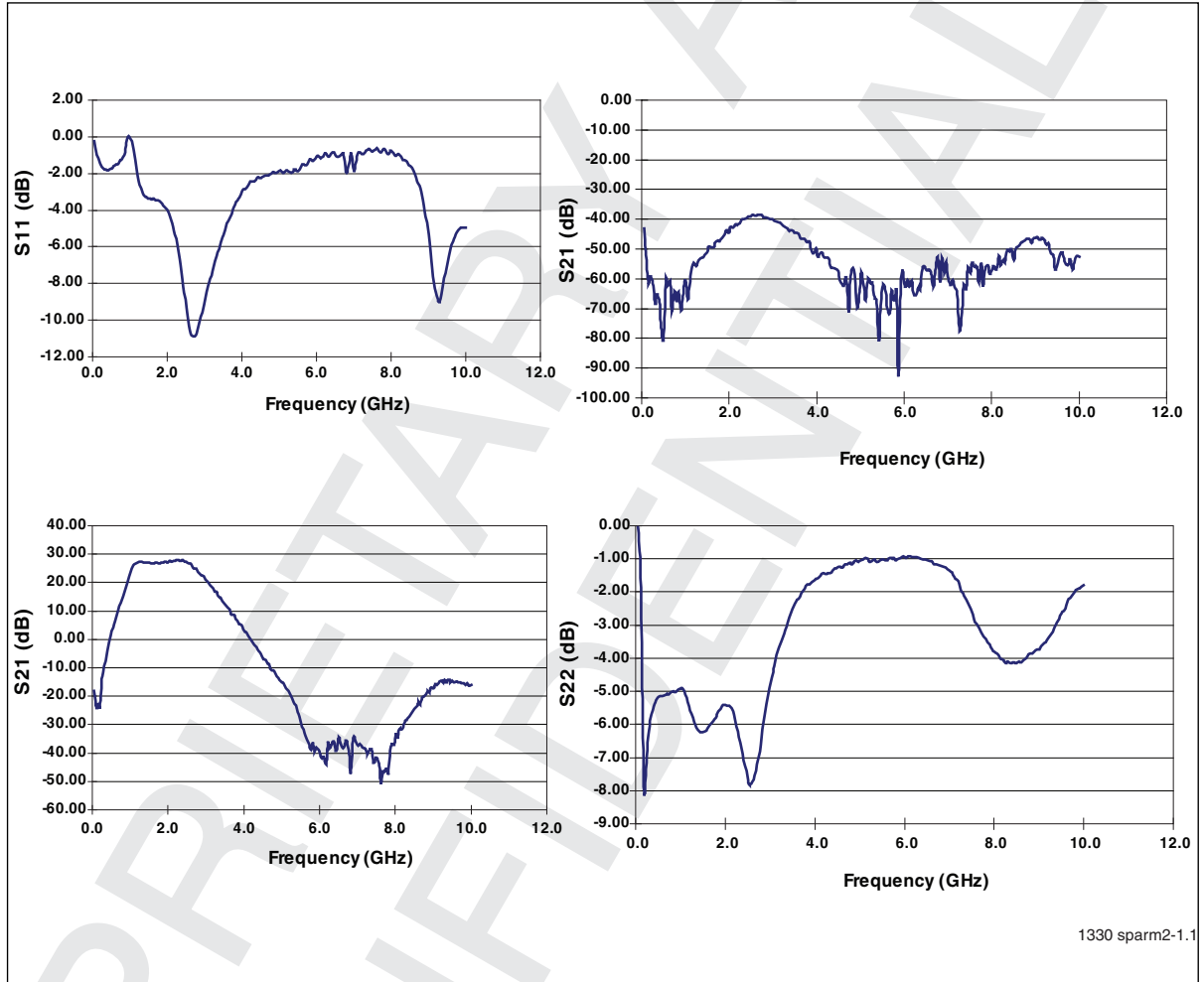

Figure 8: S-Parameters, TX Chain



Typical Performance Characteristics

Test Conditions: $f = 2.447 \text{ GHz}$, $V_{CC} = 3.3\text{V}$, $V_{REF} = 2.85\text{V}$ at room temperature
 $I_{CQ} = 70 \text{ mA}$

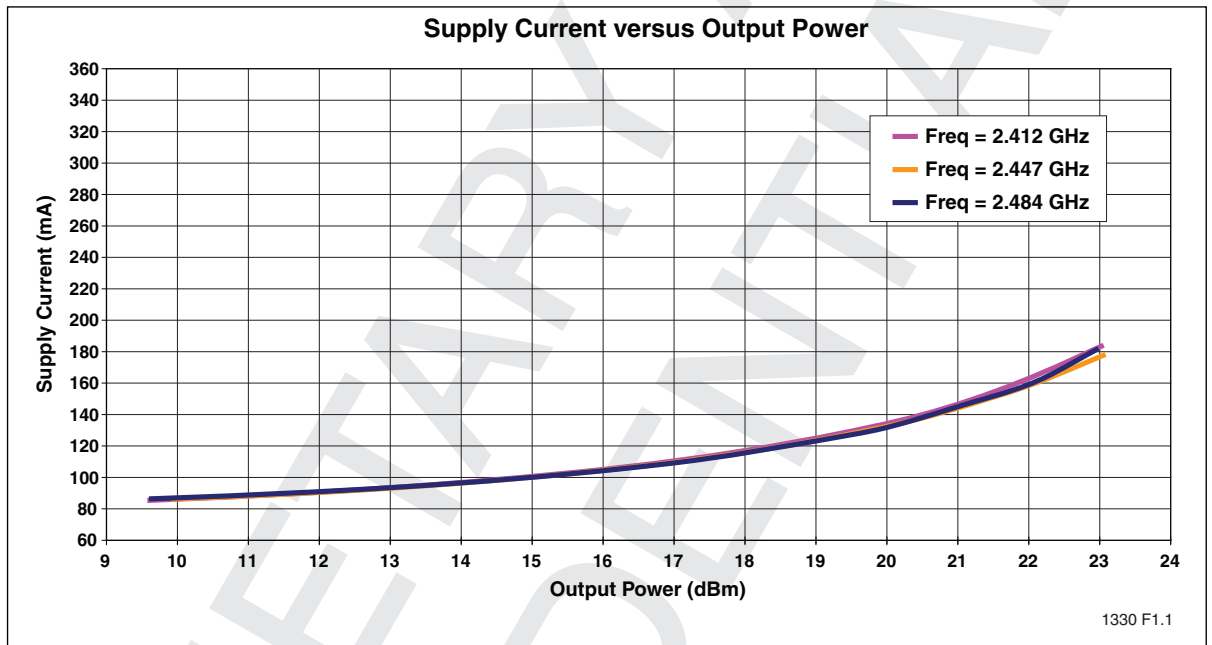

Figure 9: Supply Current versus Output Power

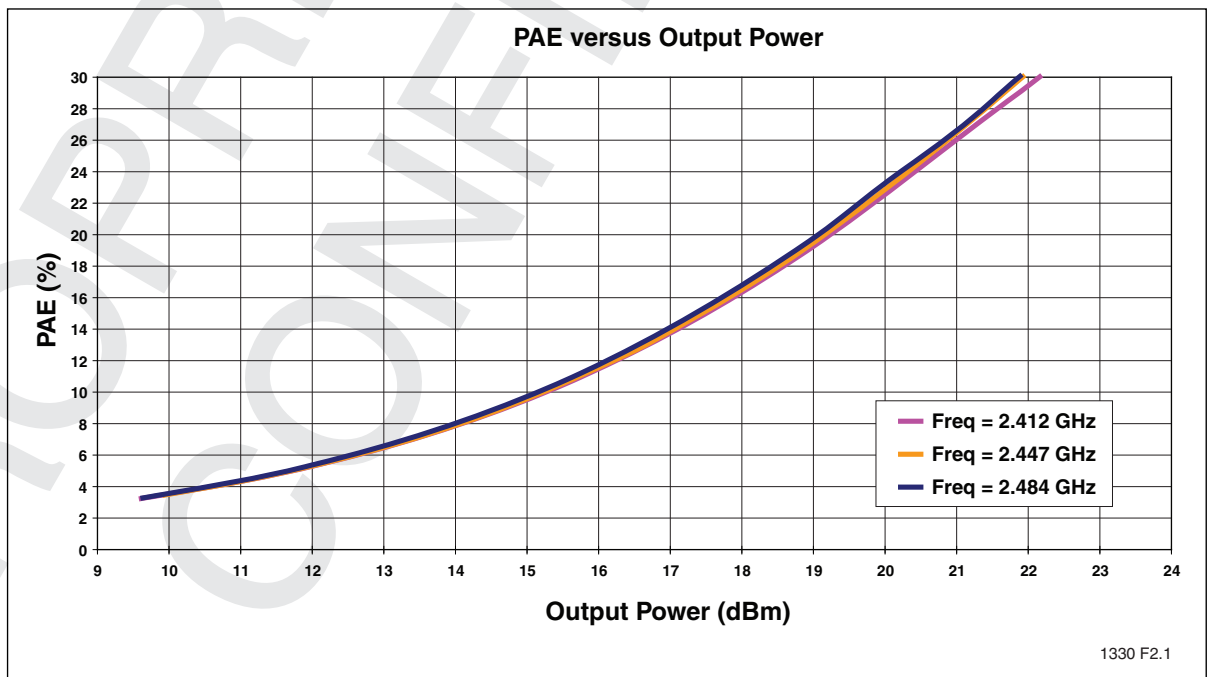

Figure 10: Power Added Efficiency (PAE) versus Output Power

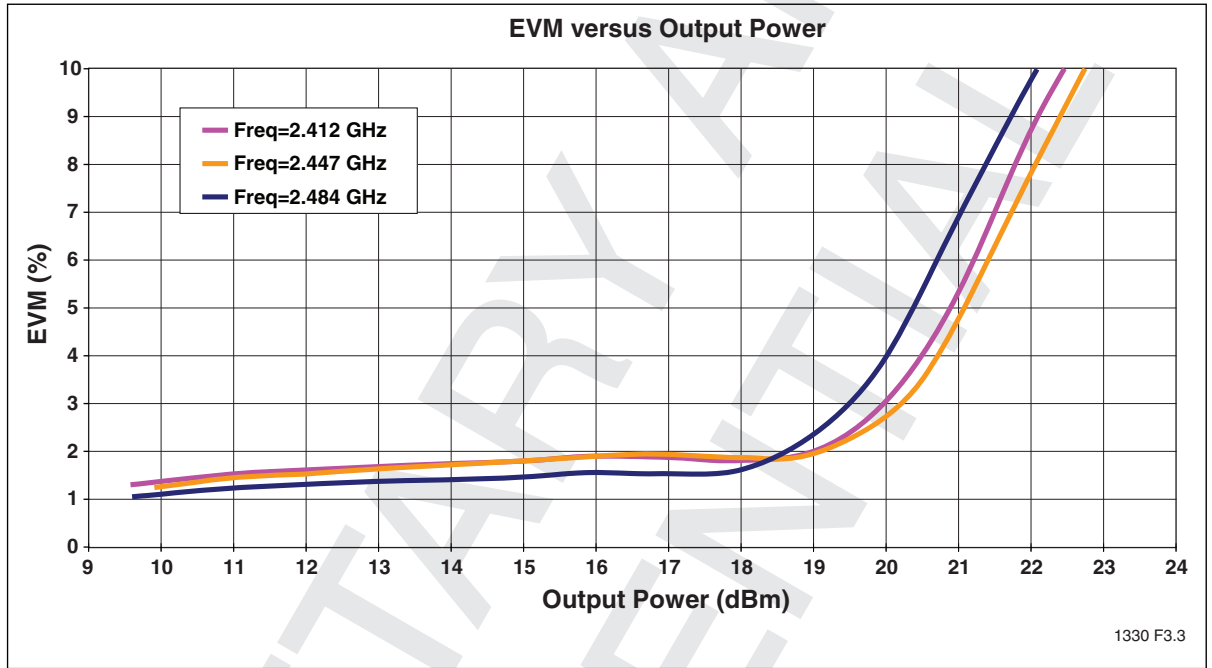

Figure 11: EVM versus Output Power, measured with Equalizer Channel Estimation set to “sequence plus data”

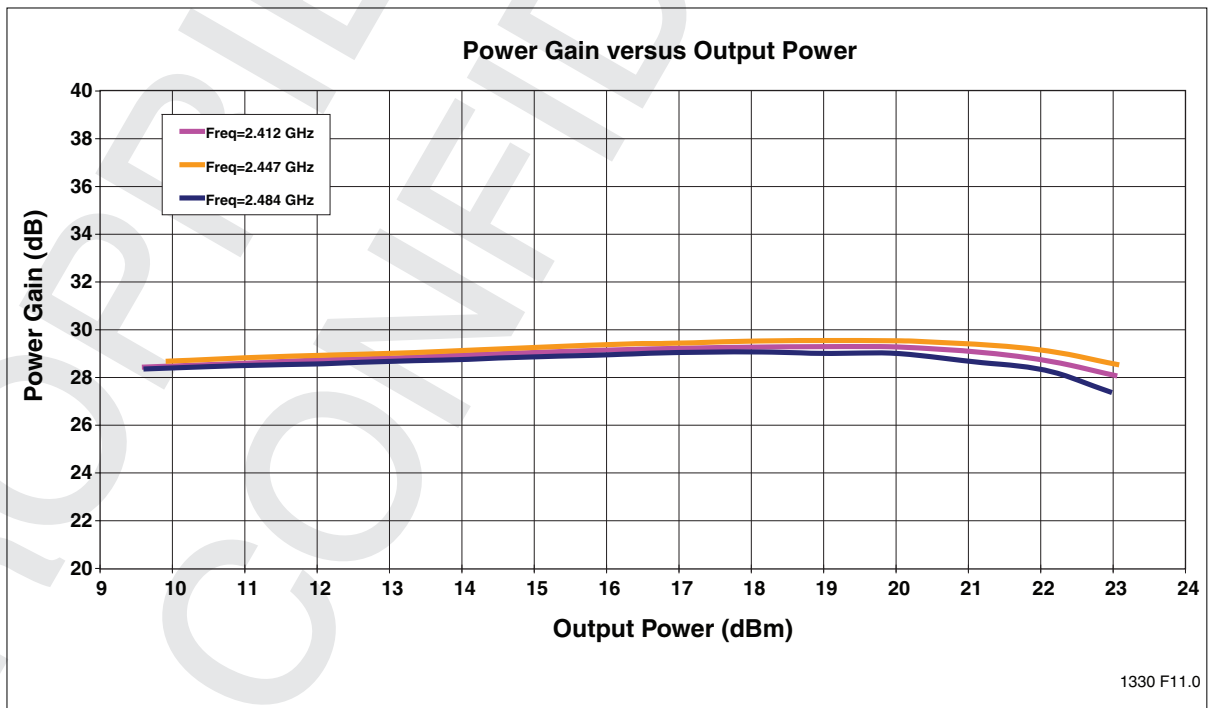

Figure 12: Power Gain versus Output Power



Test Conditions: $V_{CC} = 3.3V$, $T_A = 25^\circ C$, 54 Mbps 802.11g OFDM signal

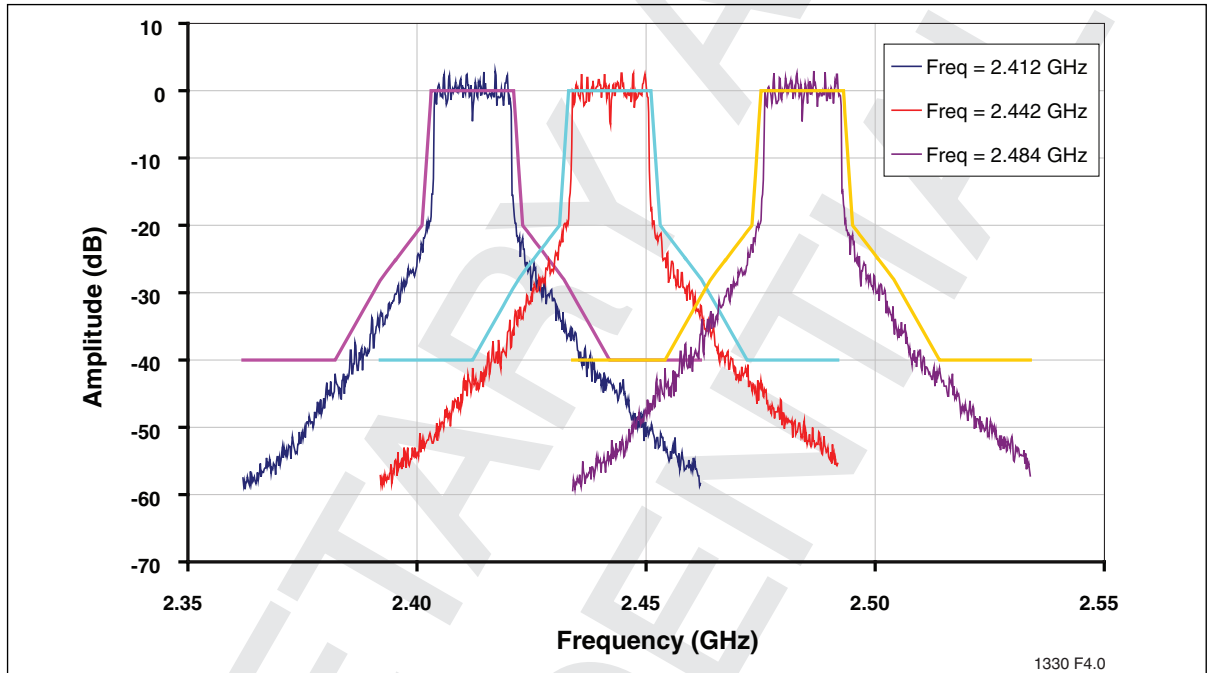

Figure 13:802.11g Spectrum Mask at 23 dBm

Test Conditions: $V_{CC} = 3.3V$, $T_A = 25^\circ C$, 1 Mbps 802.11b signal

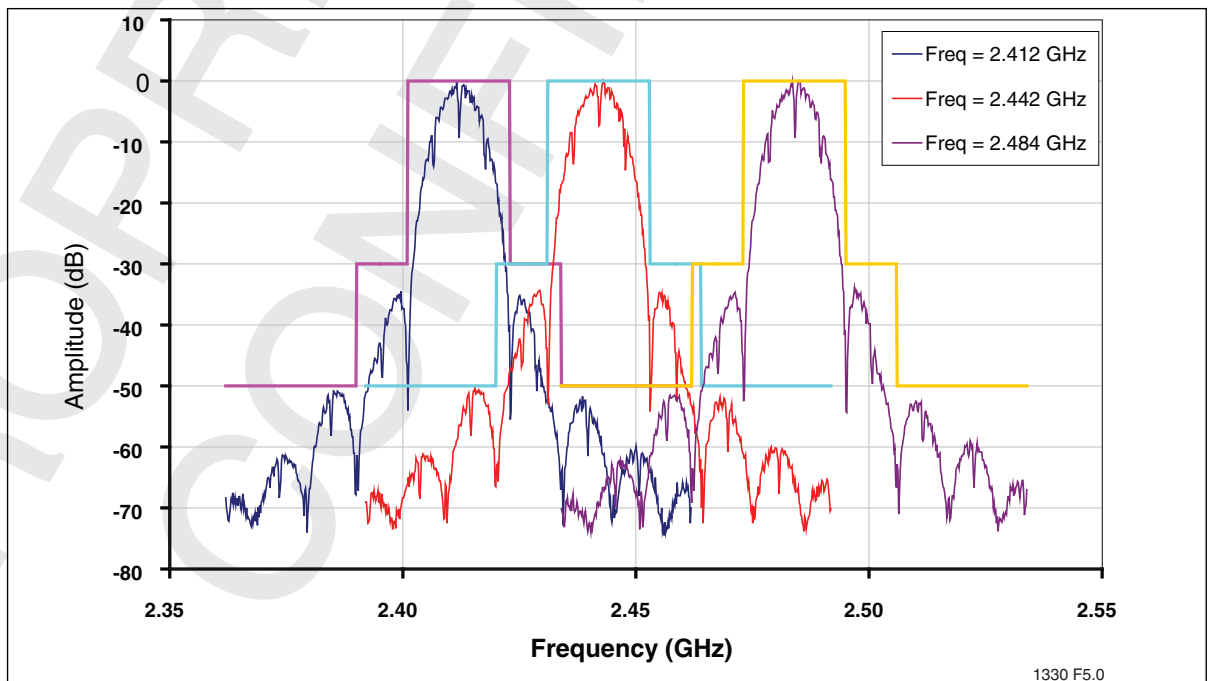

Figure 14:802.11b Spectrum Mask at 23 dBm

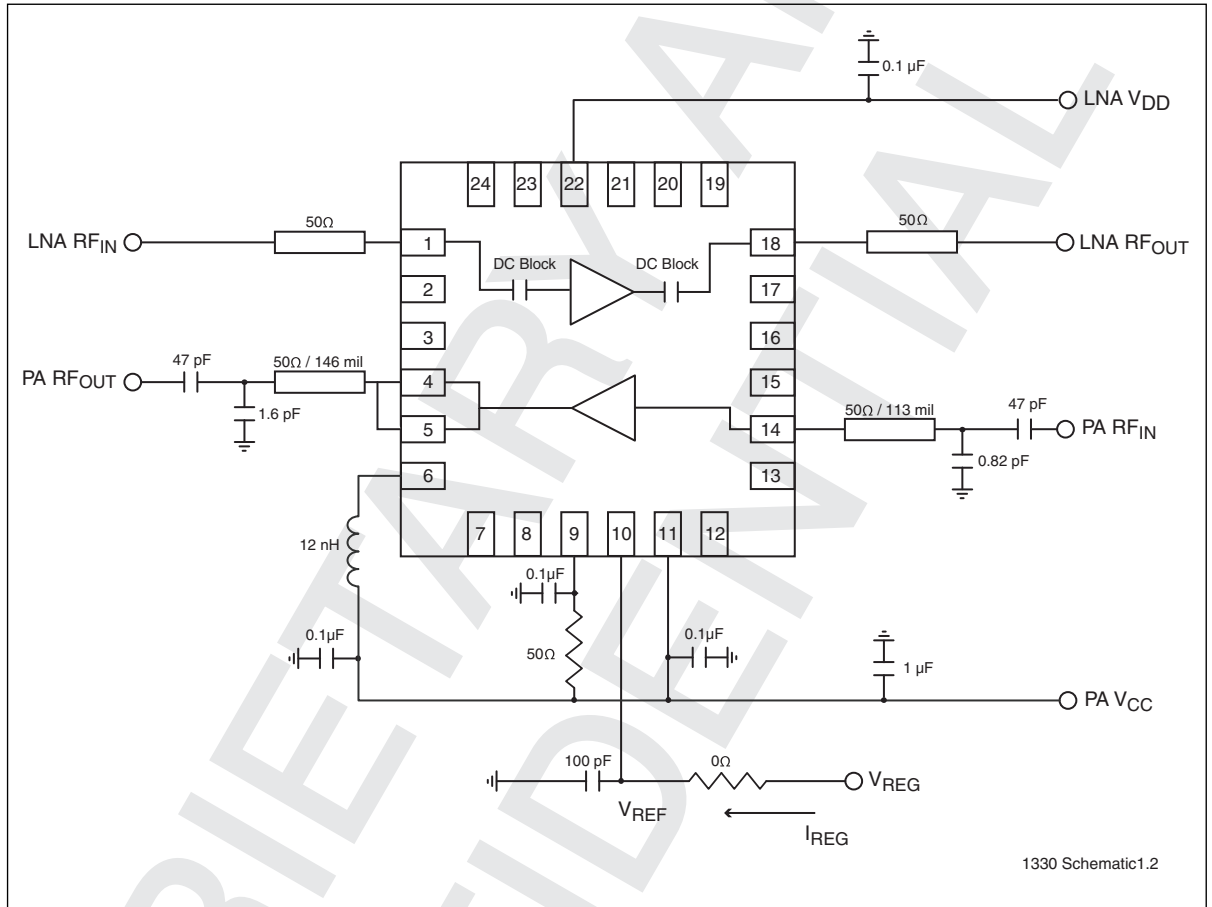
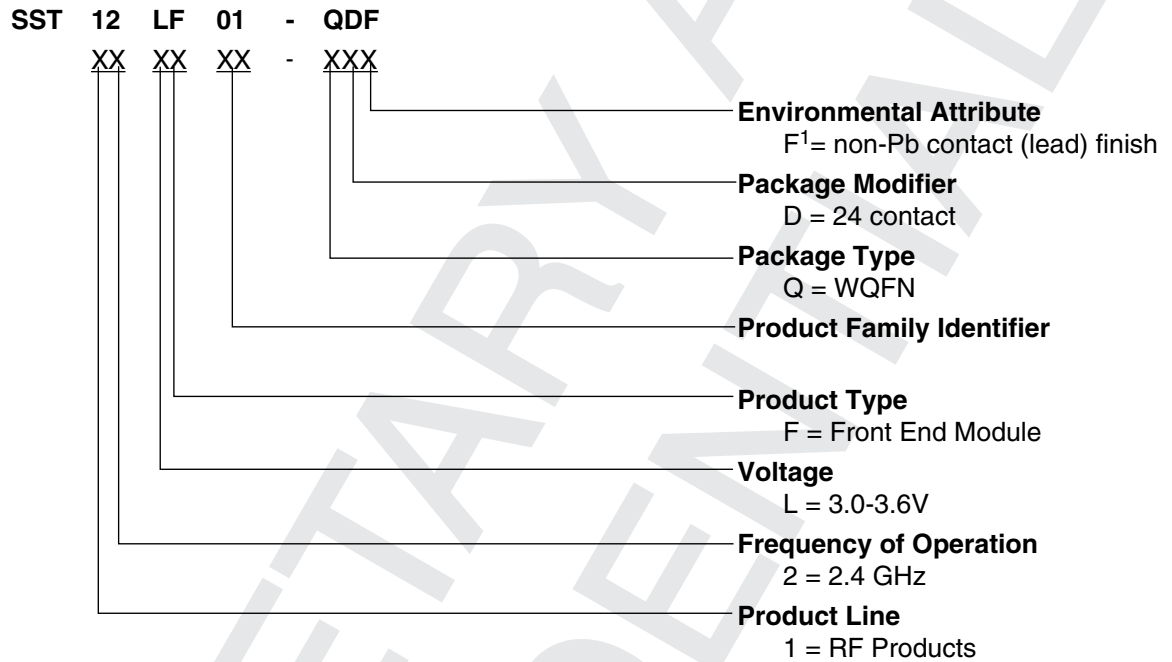

Figure 15: Typical Schematic



Product Ordering Information



1. Environmental suffix "F" denotes non-Pb solder. SST non-Pb solder devices are "RoHS Compliant".

Valid combinations for SST12LF01

SST12LF01-QDF

SST12LF01 Evaluation Kits

SST12LF01-QDF-K

Note: Valid combinations are those products in mass production or will be in mass production. Consult your SST sales representative to confirm availability of valid combinations and to determine availability of new combinations.



Packaging Diagrams

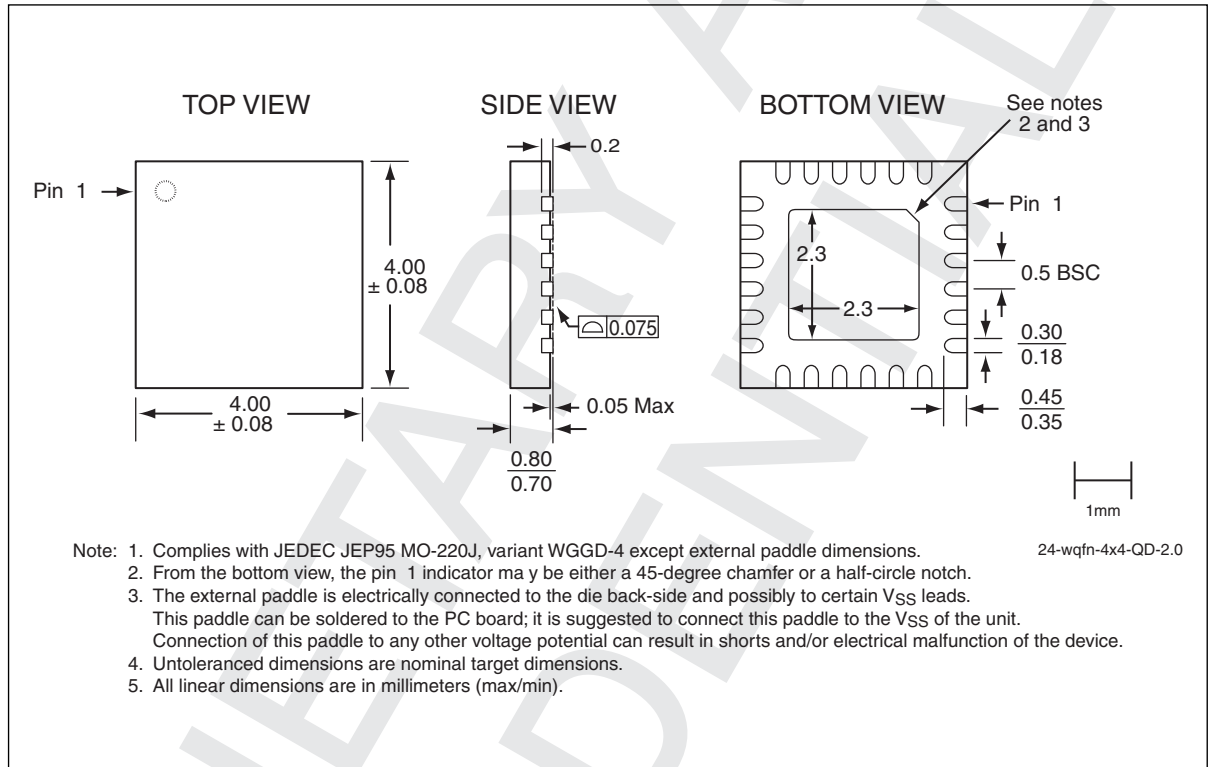

Figure 16: 24-contact Very-very-thin Quad Flat No-lead (WQFN)
SST Package Code: QD

**Table 6:** Revision History

Revision	Description	Date
00	<ul style="list-style-type: none"> Initial release of data sheet 	Sep 2006
01	<ul style="list-style-type: none"> Updated pins 9 and 11 in Figure 2 on page 4 Updated pin 6, 9, and 11 in Table 1 on page 5 Updated Figure 11 on page 15 Updated Figure 15 on page 17 	Jan 2007
02	<ul style="list-style-type: none"> Updated “Product Ordering Information” on page 18 	Sep 2007
03	<ul style="list-style-type: none"> Revised Product Description on page 1 Changed signal gain value 14 dB globally Changed low-noise figure to 1.45 dB globally Edited high temperature stability feature, page 1 Change low idle current to 75 mA, page 1 Edited Table 2, DC Electrical Characteristics; Table 3, AC Electrical Characteristics RX Chain; Table 4, AC Electrical Characteristics TX Chain Replaced Figures 3 through 11 with up-to-date graphs on pages 7 through 13 Added Figure 5 on page 8 Added Figure 12 on page 15 Edited Figure 15 on page 17 	Jun 2008
04	<ul style="list-style-type: none"> Revised RX chain gain value from 14 to 12 in “Features” and “Product Description” on page 2 and Table 4 on page 7. Updated Figures 3 and 5. 	Nov 2008
05	<ul style="list-style-type: none"> Updated contact information 	Feb 2009
06	<ul style="list-style-type: none"> Updated document status to “Data Sheet” Revised IPE values in Features on page 1 and Table 4 on page 7 Changed definition of “F” environmental attribute in “Product Ordering Information” on page 18 	Nov 2010
A	<ul style="list-style-type: none"> Removed products with an “E” environmental attribute from “Product Ordering Information” on page 18 Revised Figure 1 on page 3 and the caption of Applied new document format Released document under letter revision system Updated Spec number from S71330 to DS75040 	Dec 2011



A Microchip Technology Company

2.4 GHz Front-End Module SST12LF01

Data Sheet

ISBN:978-1-61341-864-2

© 2011 Silicon Storage Technology, Inc—a Microchip Technology Company. All rights reserved.

SST, Silicon Storage Technology, the SST logo, SuperFlash, MTP, and FlashFlex are registered trademarks of Silicon Storage Technology, Inc. MPF, SQI, Serial Quad I/O, and Z-Scale are trademarks of Silicon Storage Technology, Inc. All other trademarks and registered trademarks mentioned herein are the property of their respective owners.

Specifications are subject to change without notice. Refer to www.microchip.com for the most recent documentation. For the most current package drawings, please see the Packaging Specification located at <http://www.microchip.com/packaging>.

Memory sizes denote raw storage capacity; actual usable capacity may be less.

SST makes no warranty for the use of its products other than those expressly contained in the Standard Terms and Conditions of Sale.

For sales office locations and information, please see www.microchip.com.

Silicon Storage Technology, Inc.
A Microchip Technology Company
www.microchip.com
