



Chipsmall Limited consists of a professional team with an average of over 10 year of expertise in the distribution of electronic components. Based in Hongkong, we have already established firm and mutual-benefit business relationships with customers from,Europe,America and south Asia,supplying obsolete and hard-to-find components to meet their specific needs.

With the principle of “Quality Parts,Customers Priority,Honest Operation,and Considerate Service”,our business mainly focus on the distribution of electronic components. Line cards we deal with include Microchip,ALPS,ROHM,Xilinx,Pulse,ON,Everlight and Freescale. Main products comprise IC,Modules,Potentiometer,IC Socket,Relay,Connector.Our parts cover such applications as commercial,industrial, and automotives areas.

We are looking forward to setting up business relationship with you and hope to provide you with the best service and solution. Let us make a better world for our industry!



Contact us

Tel: +86-755-8981 8866 Fax: +86-755-8427 6832

Email & Skype: info@chipsmall.com Web: www.chipsmall.com

Address: A1208, Overseas Decoration Building, #122 Zhenhua RD., Futian, Shenzhen, China



SST12LP20 is a RF-matched power amplifier module based on the highly-reliable InGaP/GaAs HBT technology. This amplifier includes DC blocks and provides both input and output match to 50Ω. Operating over the 2.4–2.5 GHz frequency band, the amplifier typically provides 30 dB gain with 28% power-added efficiency at 21 dBm. SST12LP20 has excellent linearity with typically 18 dBm at 3% EVM for 54 Mbps 802.11g modulation, while meeting 802.11g spectrum mask at 21 dBm. It requires only two external bias components, and features easy board-level usage, along with high-speed power-up/down control through a single combined reference voltage pin. SST12LP20 is offered in an 8-contact USON package.

Features

- **High gain:**
 - Typically 30 dB gain across 2.4–2.5 GHz over temperature 0°C to +85°C and 29 dB gain from -40°C to 0°C
- **High linear output power:**
 - >24 dBm P1dB
 - Single-tone measurement. Please refer to “Absolute Maximum Stress Ratings” on page 5
 - Meets 802.11g OFDM ACPR requirement up to 21 dBm
 - ~3% added EVM up to 18 dBm for 54 Mbps 802.11g signal 802.11n HT20 ACPR requirement up to 18 dBm
 - Meets 802.11b ACPR requirement up to 21 dBm
- **High power-added efficiency/Low operating current for 802.11b/g/n applications**
 - ~28%/138 mA @ P_{OUT} = 21 dBm for 802.11b/g
- **Single-pin low I_{REF} power-up/down control**
 - I_{REF} <2 mA
- **Low idle current**
 - ~78 mA I_{CQ}
- **High-speed power-up/down**
 - Turn on/off time (10%- 90%) <100 ns
 - Typical power-up/down delay with driver delay included <200 ns
- **Low shut-down current (~2 μA)**
- **Small variation over temperature**
 - ~1 dB gain/power variation between 0°C to +85°C
- **Excellent on-chip power detection**
 - >15 dB dynamic range, dB-wise Linear Temperature stable and load insensitive
- **Input port matched to 50Ω internally**
- **Both input and output ports are DC decoupled.**
- **Packages available**
 - 8-contact USON – 2mm x 2mm x 0.55mm
- **All non-Pb (lead-free) devices are RoHS compliant**

Applications

- **WLAN (IEEE 802.11b/g/n)**
- **Home RF**
- **Cordless phones**
- **2.4 GHz ISM wireless equipment**

Product Description

SST12LP20 is a versatile power amplifier based on the highly-reliable InGaP/GaAs HBT technology. The device's input and output ports are matched to 50Ω internally. Both input and output ports are DC-decoupled and do not require DC-blocking capacitors. This helps reduce the system board's Bill of Materials (BOM) cost.

The SST12LP20 is a 2.4 GHz high-efficiency Power Amplifier designed in compliance with IEEE 802.11b/g/n applications. It typically provides 30 dB gain with 28% power-added efficiency (PAE) @ $P_{OUT} = 21$ dBm for 802.11b/g.

The SST12LP20 has excellent linearity, typically ~3% added EVM at 18 dBm output power which is essential for 54 Mbps 802.11g operation while meeting 802.11g spectrum mask at 21 dBm and 802.11b spectrum mask at 21 dBm.

The SST12LP20 also features easy board-level usage along with high-speed power-up/down control through a single combined reference voltage pin. Ultra-low reference current (total $I_{REF} \sim 2$ mA) makes the SST12LP20 controllable by an on/off switching signal directly from the baseband chip. These features, coupled with low operating current, make the SST12LP20 ideal for the final stage power amplification in battery-powered 802.11b/g/n WLAN transmitter applications.

The SST12LP20 has an excellent on-chip, single-ended power detector, which features wide-range (>15 dB) with dB-wise linear. The excellent on-chip power detector provides a reliable solution to board-level power control.

The SST12LP20 is offered in 8-contact USON package. See Figure 2 for pin assignments and Table 1 for pin descriptions.

Functional Blocks

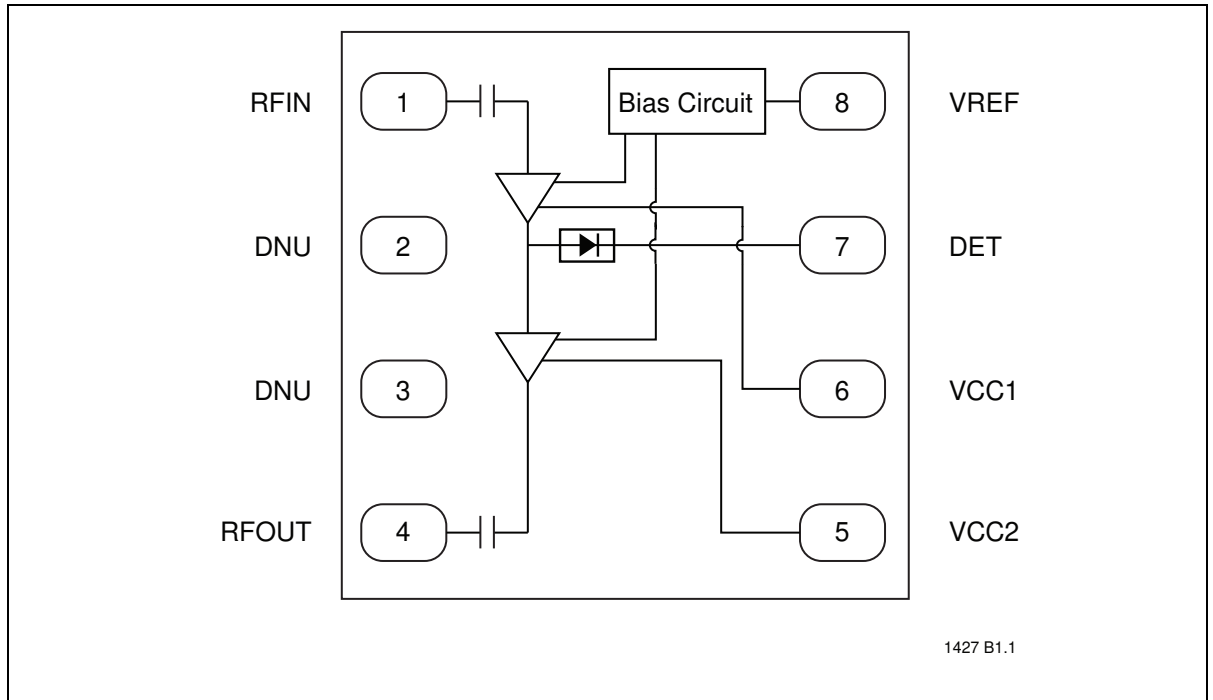

Figure 1: Functional Block Diagram

Pin Assignments

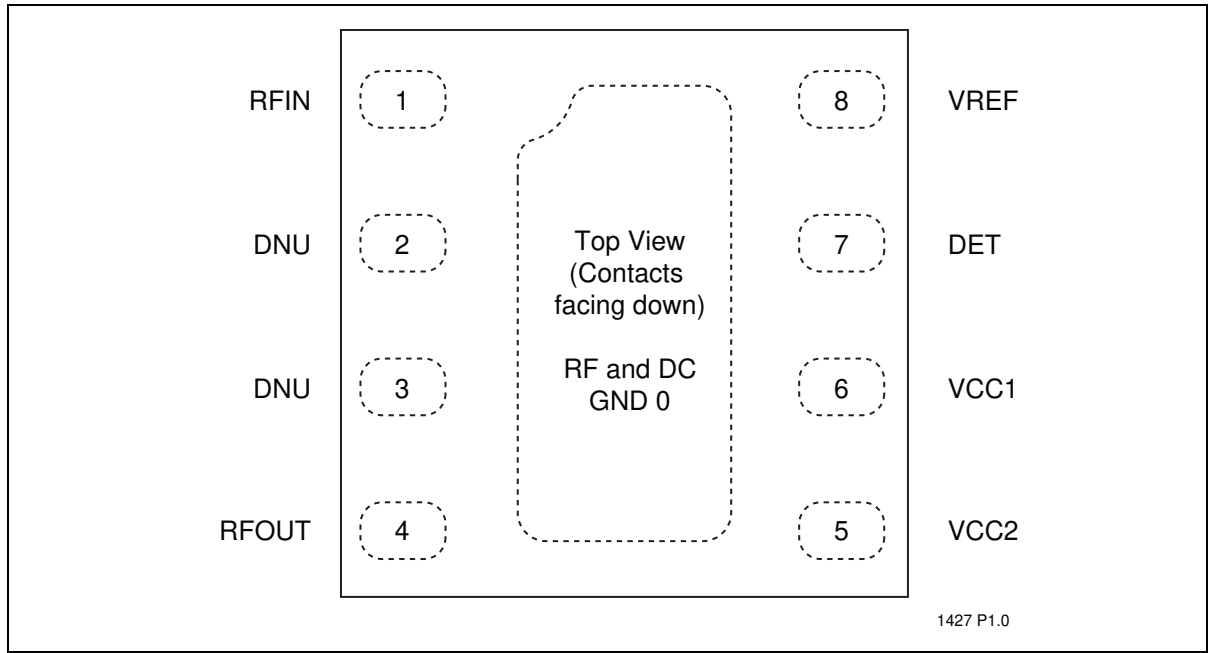

Figure 2: Pin Assignments for 8-contact USON

Pin Descriptions

Table 1: Pin Description

Symbol	Pin No.	Pin Name	Type ¹	Function
GND	0	Ground		Low inductance ground pad
RFIN	1		I	RF input, DC decoupled
DNU	2	Do Not Use		Do not use or connect
DNU	3	Do Not Use		Do not use or connect
RFOUT	4		O	RF output, DC decoupled
VCC2	5	Power Supply	PWR	Power Supply, 2 nd stage
VCC1	6	Power Supply	PWR	Power Supply, 1 st stage
DET	7		O	On-chip power detector
VREF	8		PWR	1 st and 2 nd stage idle current control

1. I=Input, O=Output

T1.0 75049

Electrical Specifications

The RF and DC specifications for the power amplifier interface signals. Refer to Table 3 for the DC voltage and current specifications, Table 4 for RF specifications, and Figures 3 through 8 for the RF performance.

Absolute Maximum Stress Ratings (Applied conditions greater than those listed under “Absolute Maximum Stress Ratings” may cause permanent damage to the device. This is a stress rating only and functional operation of the device at these conditions or conditions greater than those defined in the operational sections of this data sheet is not implied. Exposure beyond absolute maximum stress rating conditions may affect device reliability.)

Input power to pin 1 (P_{IN})	+5 dBm
Average output power from pin 4 (P_{OUT}) ¹	+25.5 dBm
Supply Voltage at pins 5 and 6 (V_{CC})	-0.3V to +4.8V
Reference voltage to pin 8 (V_{REF})	-0.3V to +4.0V
DC supply current (I_{CC}) ²	350 mA
Operating Temperature (T_A)	-40°C to +85°C
Storage Temperature (T_{STG})	-40°C to +120°C
Maximum Junction Temperature (T_J)	+150°C
Surface Mount Solder Reflow Temperature	260°C for 10 seconds

- Never measure with CW source. Pulsed single-tone source with <50% duty cycle is recommended. Exceeding the maximum rating of average output power could cause permanent damage to the device.
- Measured with 100% duty cycle 54 Mbps 802.11g OFDM Signal

Table 2: Operating Range

Range	Ambient Temp	V_{DD}
Industrial	-40°C to +85°C	3.3V

T2.1 75049

Table 3: DC Electrical Characteristics at 25°C

Symbol	Parameter	Min.	Typ	Max.	Unit
V_{CC}	Supply Voltage at pins 5 and 6	3.0	3.3	4.2	V
I_{CQ}	Idle current to meet EVM ~3% @ 18 dBm Output Power, 802.11g OFDM 54 Mbps signal		75		mA
V_{REG}	Reference Voltage for pin 8	3.05	3.10	3.15	V
I_{CC}	Current consumption to meet 802.11g OFDM 54 Mbps spectrum mask @ 21 dBm		140		mA
	Current consumption to meet 802.11b DSSS 54 Mbps spectrum mask @ 21 dBm		140		mA
	Current consumption to meet EVM ~3% @ 18 dBm Output Power with 802.11g OFDM 54 Mbps signal		110		mA

T3.1 75049

Table 4: RF Characteristics at 25°C

Symbol	Parameter	Min.	Typ	Max.	Unit
F _{L-U}	Frequency range	2412		2484	MHz
G	Small signal gain	28	30		dB
G _{VAR1}	Gain variation over band (2412–2484 MHz)			±0.5	dB
G _{VAR2}	Gain ripple over channel (20 MHz)		0.2		dB
2f, 3f, 4f, 5f	Harmonics at 22 dBm, without external filters		-25		dBc
EVM	Added EVM @ 18 dBm output with 802.11g OFDM 54 Mbps signal		3		%
P _{OUT}	Output Power to meet 802.11g OFDM 54 Mbps spectrum mask	20	21		dBm
	Output Power to meet 802.11b DSSS 1 Mbps spectrum mask	20	21		dBm
	Output Power to meet 802.11n HT20 65 Mbps spectrum mask	18	20		dBm

T4.2 75049

Typical Performance Characteristics

Test Conditions: $V_{CC} = 3.3V$, $T_A = 25^\circ C$, unless otherwise specified

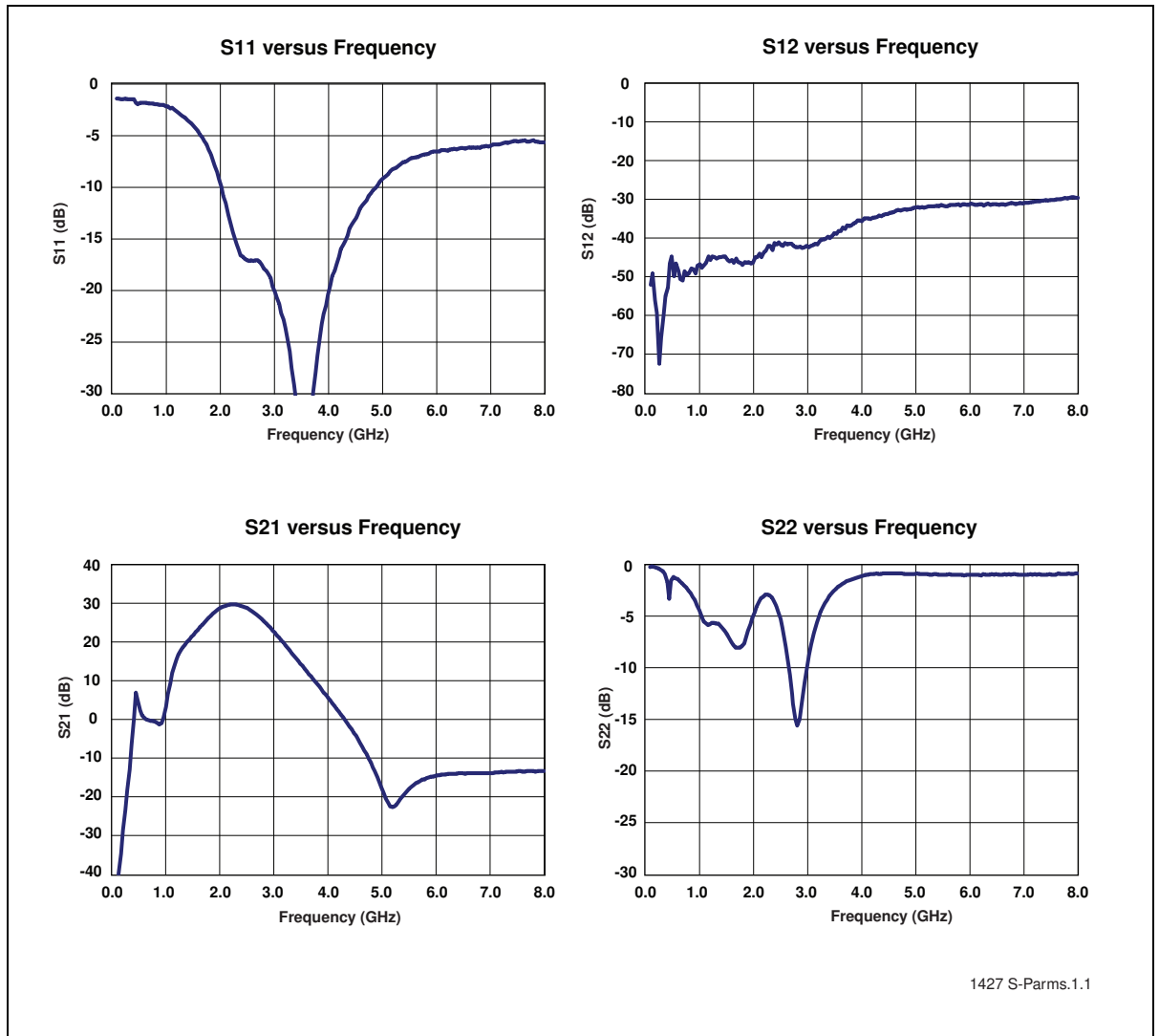

Figure 3: S-Parameters

Typical Performance Characteristics

Test Conditions: $V_{CC} = 3.3V$, $T_A = 25^\circ C$, 54 Mbps 802.11g OFDM Signal

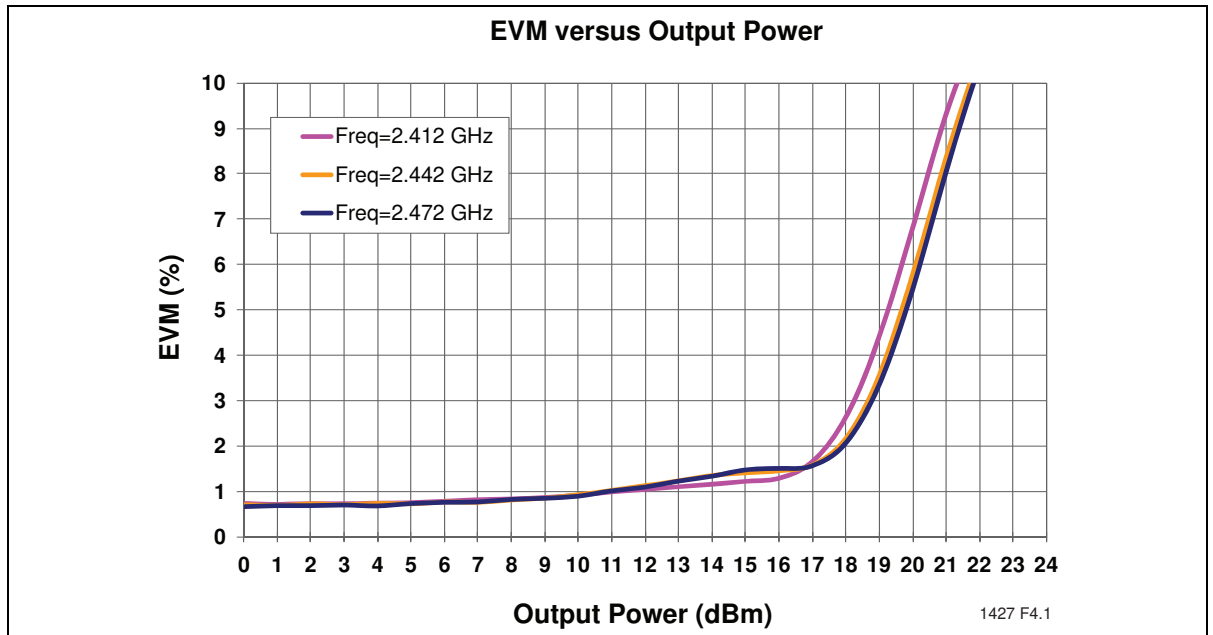

Figure 4: EVM versus Output Power measured with Equalizer Channel Estimation set to "Sequence Only"

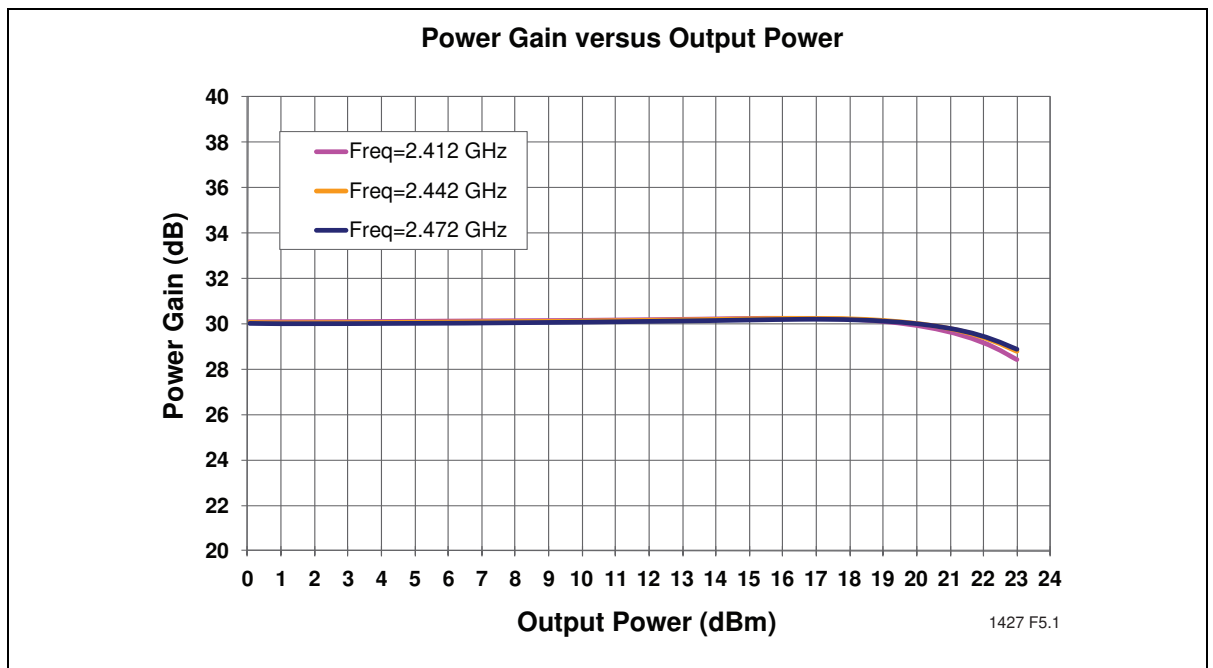

Figure 5: Power Gain versus Output Power

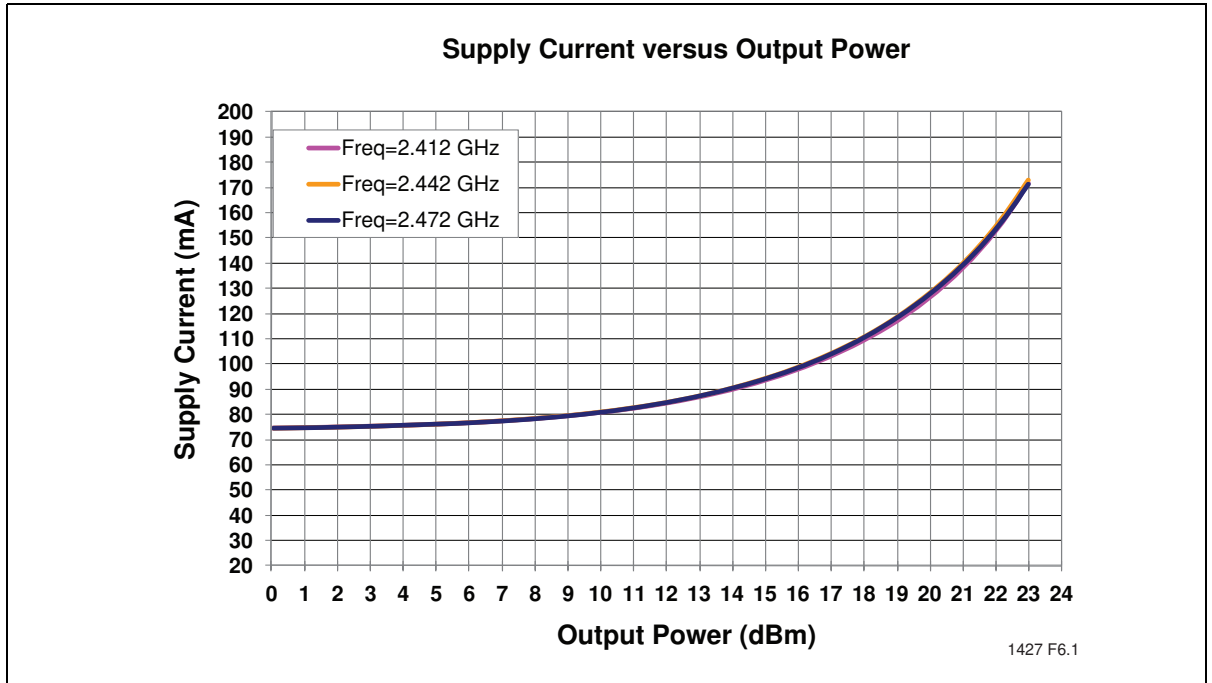

Figure 6: Total Current Consumption for 802.11g operation versus Output Power

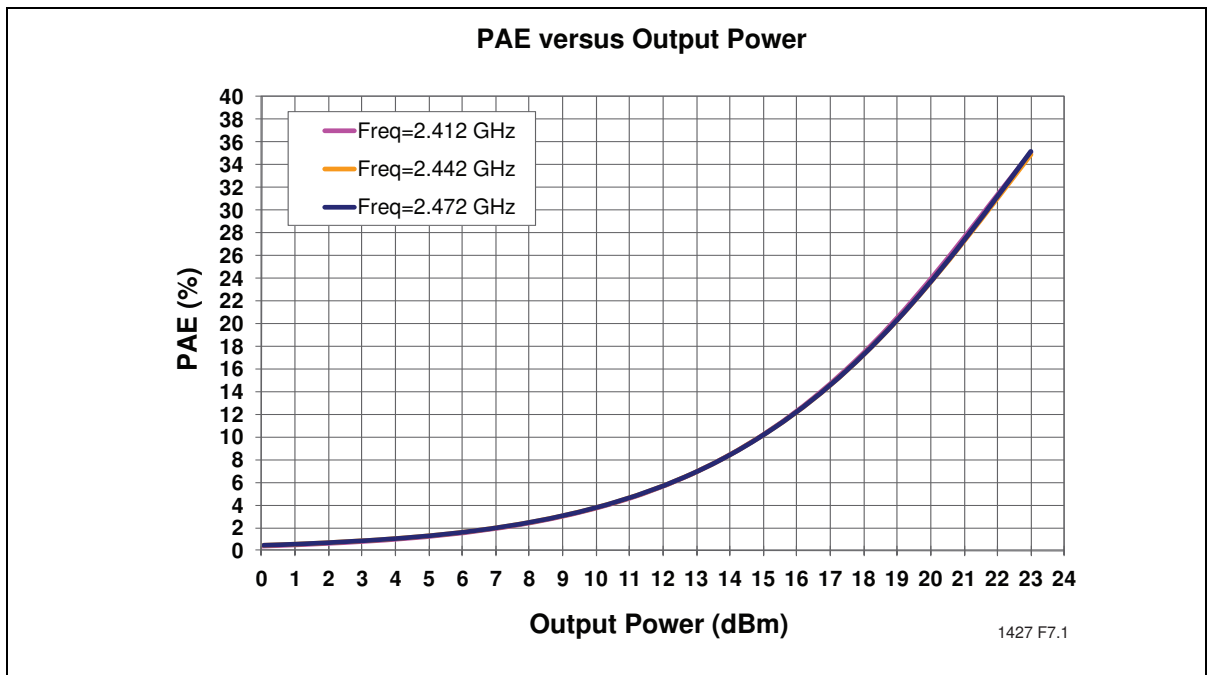

Figure 7: PAE versus Output Power

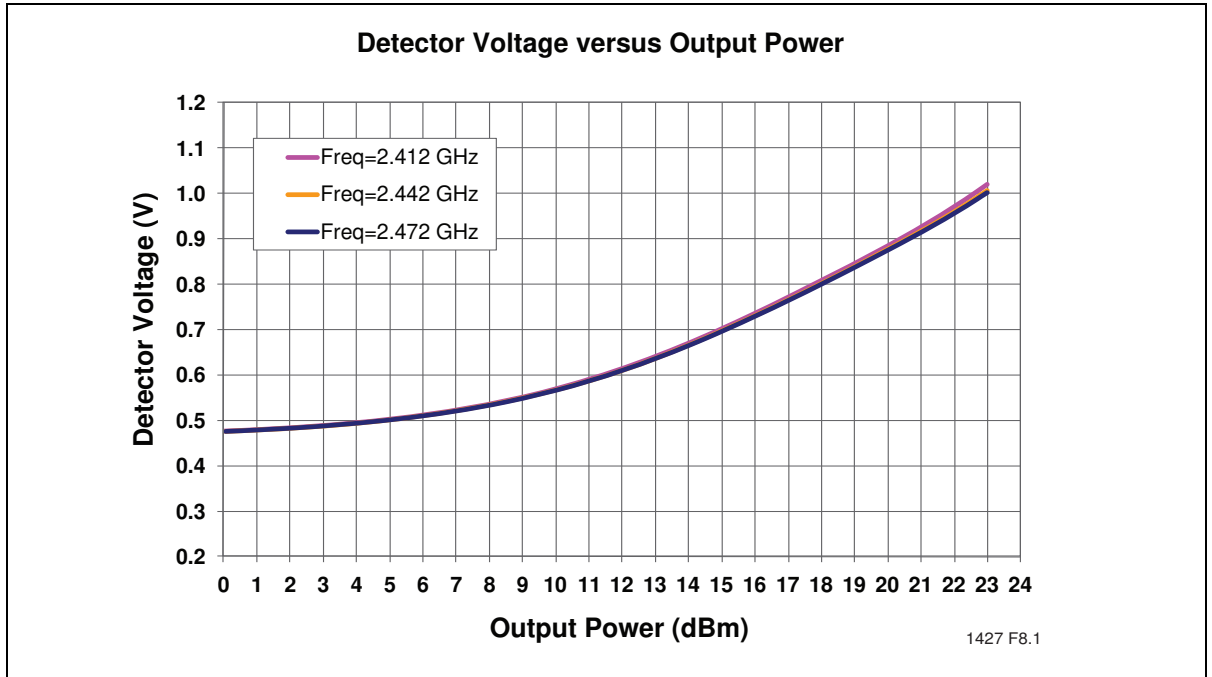

Figure 8: Detector Characteristics versus Output Power

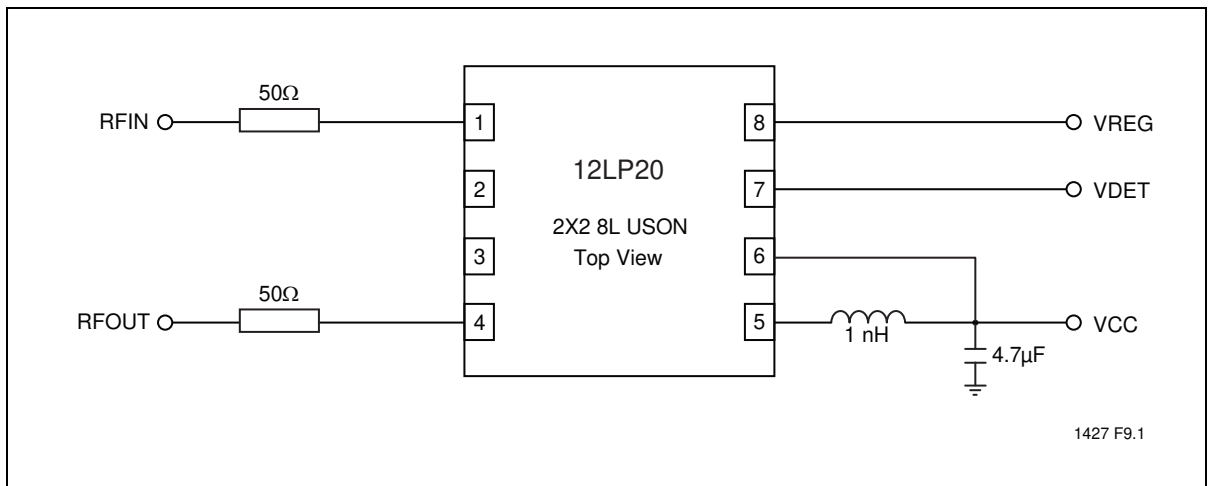
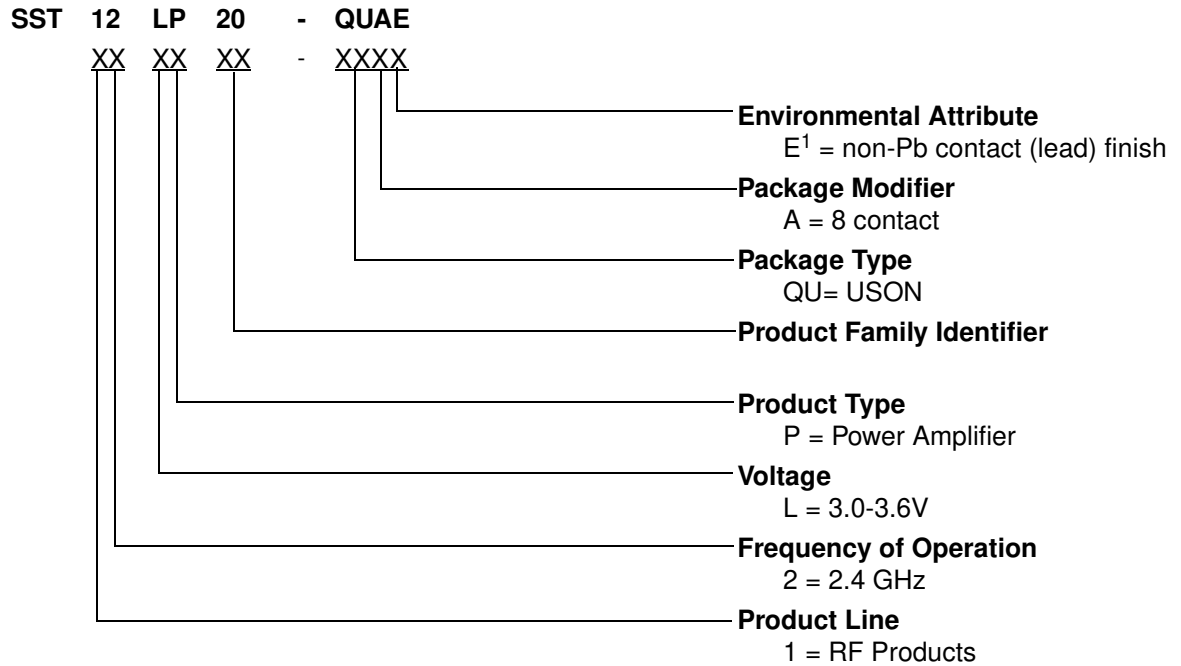

Figure 9: Typical Schematic for High-Efficiency 802.11b/g Applications

Product Ordering Information



1. Environmental suffix "E" denotes non-Pb solder. SST non-Pb solder devices are "RoHS Compliant".

Valid combinations for SST12LP20

SST12LP20-QUAE

SST12LP20 Evaluation Kits

SST12LP20-QUAE-K

Note: Valid combinations are those products in mass production or will be in mass production. Consult your SST sales representative to confirm availability of valid combinations and to determine availability of new combinations.

Packaging Diagrams

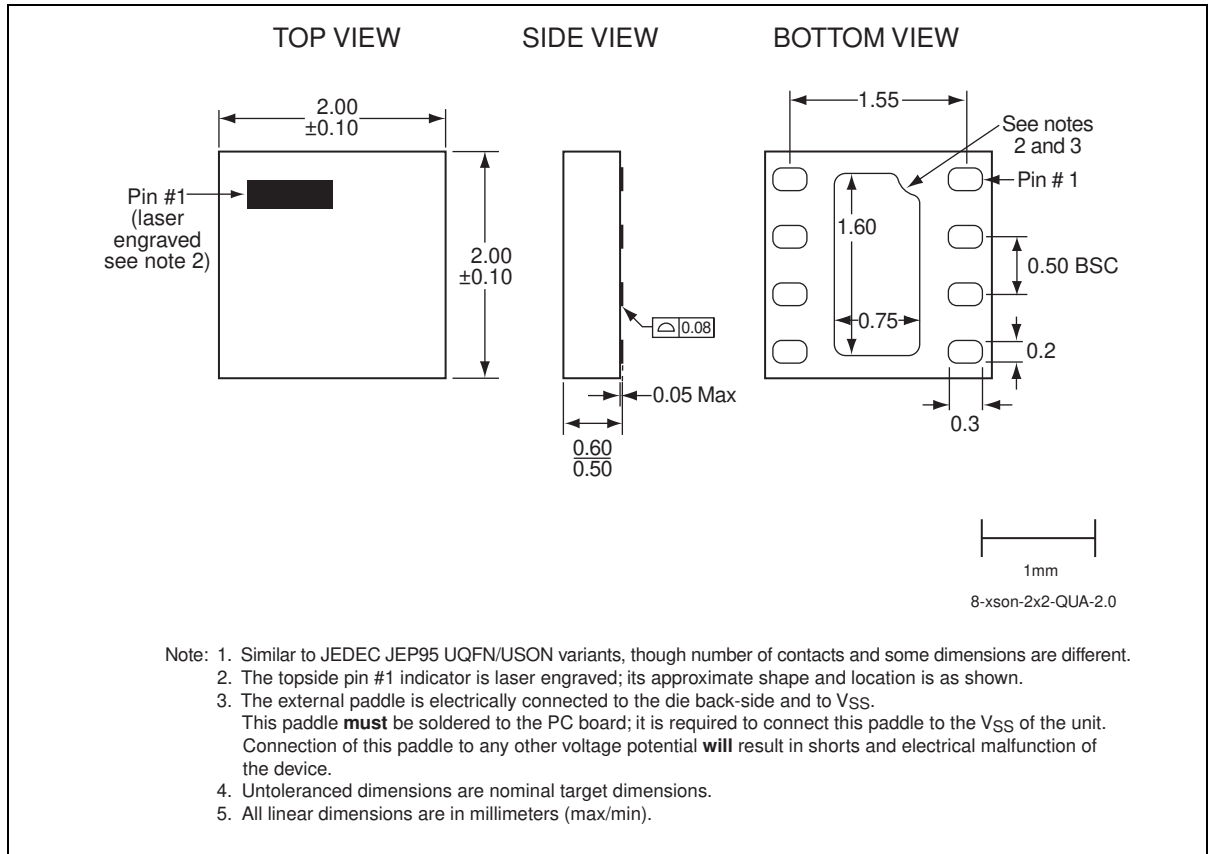

Figure 10:8-Contact Ultra-thin Small Outline No-lead (USON)
SST Package Code: QUA

Table 5:Revision History

Revision	Description	Date
00	<ul style="list-style-type: none"> Initial release of data sheet 	May 2010
A	<ul style="list-style-type: none"> Revised “Features” on page 1 and “Product Description” on page 2 Updated Figure 1 and Figures 3-9 Modified Tables 3 and 4 Applied new document format Released document under letter revision system Updated Spec number from S71427 to DS75049 	Jan 2012
B	<ul style="list-style-type: none"> Revised maximum Reference voltage from 3.3V to 4.0V in “Absolute Maximum Stress Ratings” on page 5 Updated Figure 10 on page 12 	Apr 2012
C	<ul style="list-style-type: none"> Changed the document status from “Preliminary Specification” to “Data Sheet” 	May 2013

ISBN:978-1-62077-210-2

© 2013 Silicon Storage Technology, Inc—a Microchip Technology Company. All rights reserved.

SST, Silicon Storage Technology, the SST logo, SuperFlash, MTP, and FlashFlex are registered trademarks of Silicon Storage Technology, Inc. MPF, SQI, Serial Quad I/O, and Z-Scale are trademarks of Silicon Storage Technology, Inc. All other trademarks and registered trademarks mentioned herein are the property of their respective owners.

Specifications are subject to change without notice. Refer to www.microchip.com for the most recent documentation. For the most current package drawings, please see the Packaging Specification located at <http://www.microchip.com/packaging>.

Memory sizes denote raw storage capacity; actual usable capacity may be less.

SST makes no warranty for the use of its products other than those expressly contained in the Standard Terms and Conditions of Sale.

For sales office locations and information, please see www.microchip.com.

Silicon Storage Technology, Inc.
A Microchip Technology Company
www.microchip.com
