



Chipsmall Limited consists of a professional team with an average of over 10 year of expertise in the distribution of electronic components. Based in Hongkong, we have already established firm and mutual-benefit business relationships with customers from,Europe,America and south Asia,supplying obsolete and hard-to-find components to meet their specific needs.

With the principle of “Quality Parts,Customers Priority,Honest Operation,and Considerate Service”,our business mainly focus on the distribution of electronic components. Line cards we deal with include Microchip,ALPS,ROHM,Xilinx,Pulse,ON,Everlight and Freescale. Main products comprise IC,Modules,Potentiometer,IC Socket,Relay,Connector.Our parts cover such applications as commercial,industrial, and automotives areas.

We are looking forward to setting up business relationship with you and hope to provide you with the best service and solution. Let us make a better world for our industry!



Contact us

Tel: +86-755-8981 8866 Fax: +86-755-8427 6832

Email & Skype: info@chipsmall.com Web: www.chipsmall.com

Address: A1208, Overseas Decoration Building, #122 Zhenhua RD., Futian, Shenzhen, China



SSTUG32868

1.8 V 28-bit 1 : 2 configurable registered buffer with parity for
DDR2-1G RDIMM applications

Rev. 01 — 23 April 2007

Product data sheet

1. General description

The SSTUG32868 is a 1.8 V 28-bit 1 : 2 register specifically designed for use on two rank by four (2R × 4) and similar high-density Double Data Rate 2 (DDR2) memory modules. It is similar in function to the JEDEC-standard 14-bit DDR2 register, but integrates the functionality of the normally required two registers in a single package, thereby freeing up board real-estate and facilitating routing to accommodate high-density Dual In-line Memory Module (DIMM) designs.

The SSTUG32868 also integrates a parity function, which accepts a parity bit from the memory controller, compares it with the data received on the D-inputs and indicates whether a parity error has occurred on its open-drain \overline{QERR} pin (active LOW).

It further offers added features over the JEDEC standard register in that it is permanently configured for high output drive strength. This allows use in high density designs with heavier than normal net loading conditions. Furthermore, the SSTUG32868 features two additional chip select inputs, which allow more versatile enabling and disabling in densely populated memory modules. Both added features (drive strength and chip selects) are fully backward compatible to the JEDEC standard register. Finally, the SSTUG32868 is optimized for the fastest propagation delay in the SSTU family of registers.

The SSTUG32868 is packaged in a 176-ball, 8 × 22 grid, 0.65 mm ball pitch, thin profile fine-pitch ball grid array (TFBGA) package, which (while requiring a minimum 6 mm × 15 mm of board space) allows for adequate signal routing and escape using conventional card technology.

2. Features

- 28-bit data register supporting DDR2
- Fully compliant to JEDEC standard for SSTUB32868
- Supports 2 rank by 4 DIMM density by integrating equivalent functionality of two JEDEC-standard DDR2 registers (that is, 2 × SSTUA32864 or 2 × SSTUA32866)
- Parity checking function across 22 input data bits
- Parity out signal
- Controlled multi-impedance output impedance drivers enable optimal signal integrity and speed
- Meets or exceeds SSTUB32868 JEDEC standard speed performance
- Supports up to 450 MHz clock frequency of operation
- Permanently configured for high output drive
- Optimized pinout for high-density DDR2 module design
- Chip-selects minimize power consumption by gating data outputs from changing state

- Two additional chip select inputs allow optional flexible enabling and disabling
- Supports Stub Series Terminated Logic SSTL_18 data inputs
- Differential clock (CK and \overline{CK}) inputs
- Supports Low Voltage Complementary Metal Oxide Semiconductor (LVCMOS) switching levels on the control and RESET inputs
- Single 1.8 V supply operation (1.7 V to 2.0 V)
- Available in 176-ball 6 mm × 15 mm, 0.65 mm ball pitch TFBGA package

3. Applications

- 400 MT/s to 800 MT/s high-density (for example, 2 rank by 4) DDR2 registered DIMMs
- DDR2 Registered DIMMs (RDIMM) desiring parity checking functionality

4. Ordering information

Table 1. Ordering information

Type number	Solder process	Package		
		Name	Description	Version
SSTUG32868ET/G	Pb-free (SnAgCu solder ball compound)	TFBGA176	plastic thin fine-pitch ball grid array package; 176 balls; body 6 × 15 × 0.7 mm	SOT932-1
SSTUG32868ET/S	Pb-free (SnAgCu solder ball compound)	TFBGA176	plastic thin fine-pitch ball grid array package; 176 balls; body 6 × 15 × 0.7 mm	SOT932-1

4.1 Ordering options

Table 2. Ordering options

Type number	Temperature range
SSTUG32868ET/G	T _{amb} = 0 °C to +70 °C
SSTUG32868ET/S	T _{amb} = 0 °C to +85 °C

5. Functional diagram

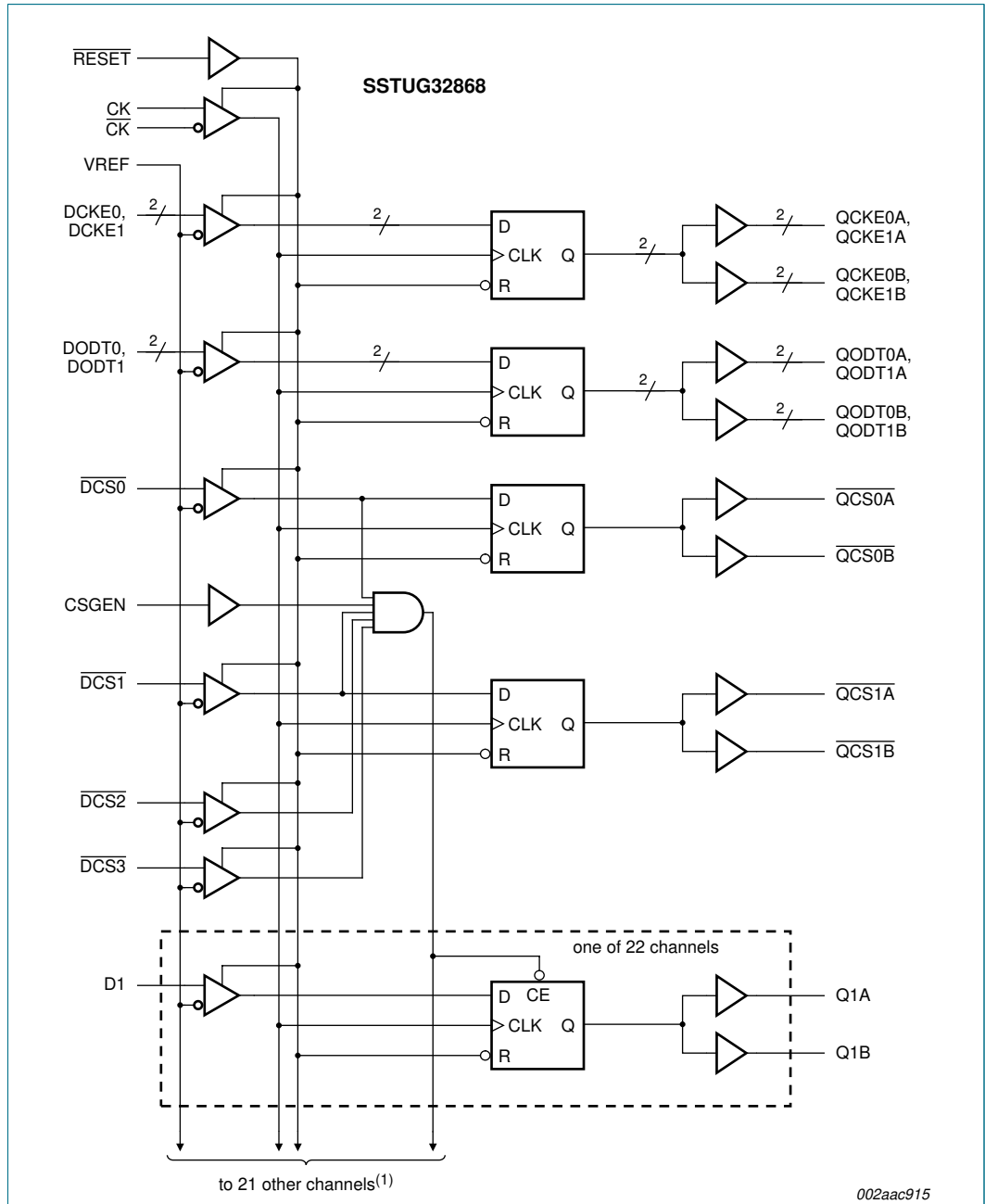

(1) Register A configuration (C = 0): D2 to D5, D7, D9 to D12, D17 to D28
 Register B configuration (C = 1): D2 to D12, D17 to D20, D22, D24 to D28

Fig 1. Logic diagram of SSTUG32868 (positive logic)

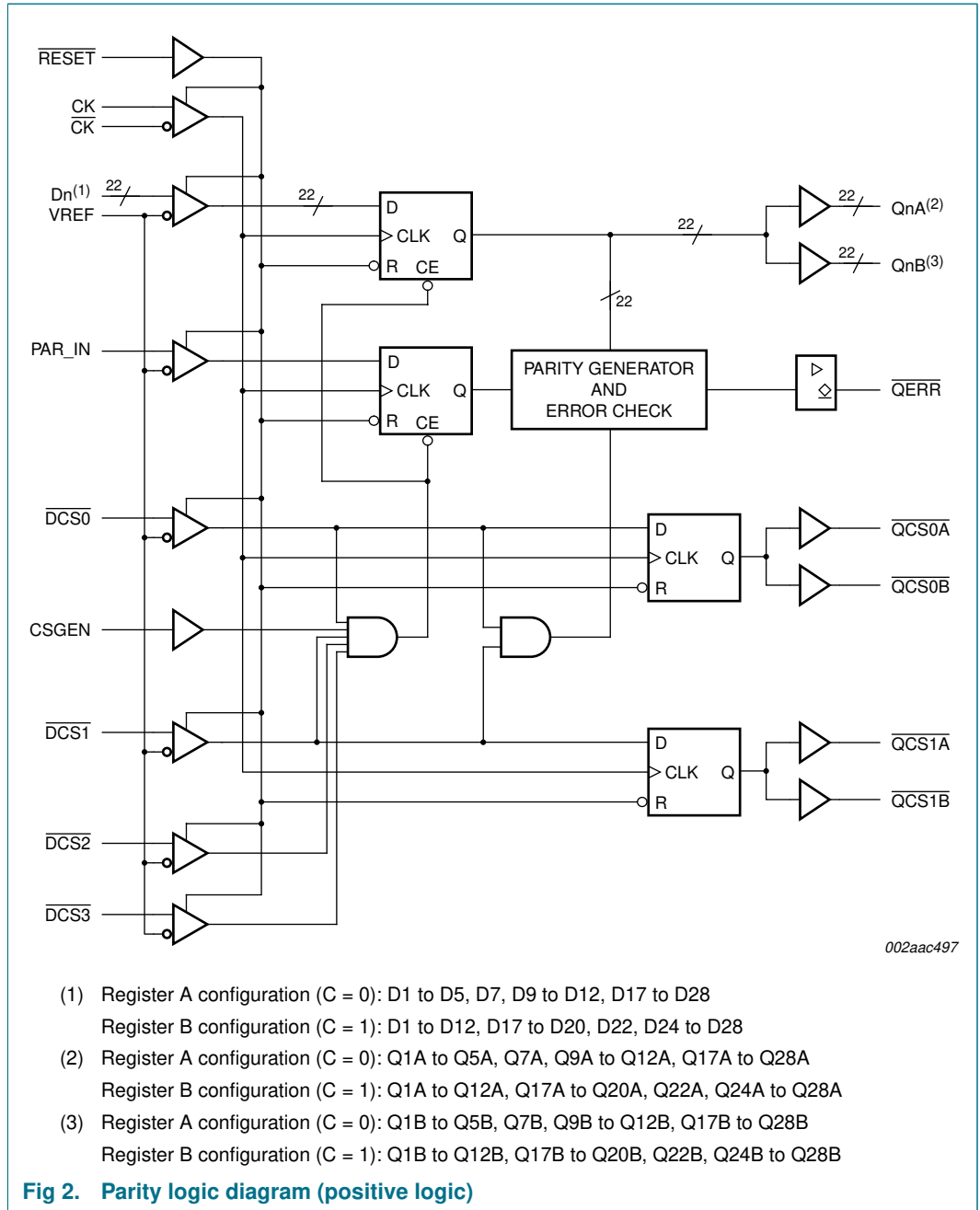

6. Pinning information

6.1 Pinning

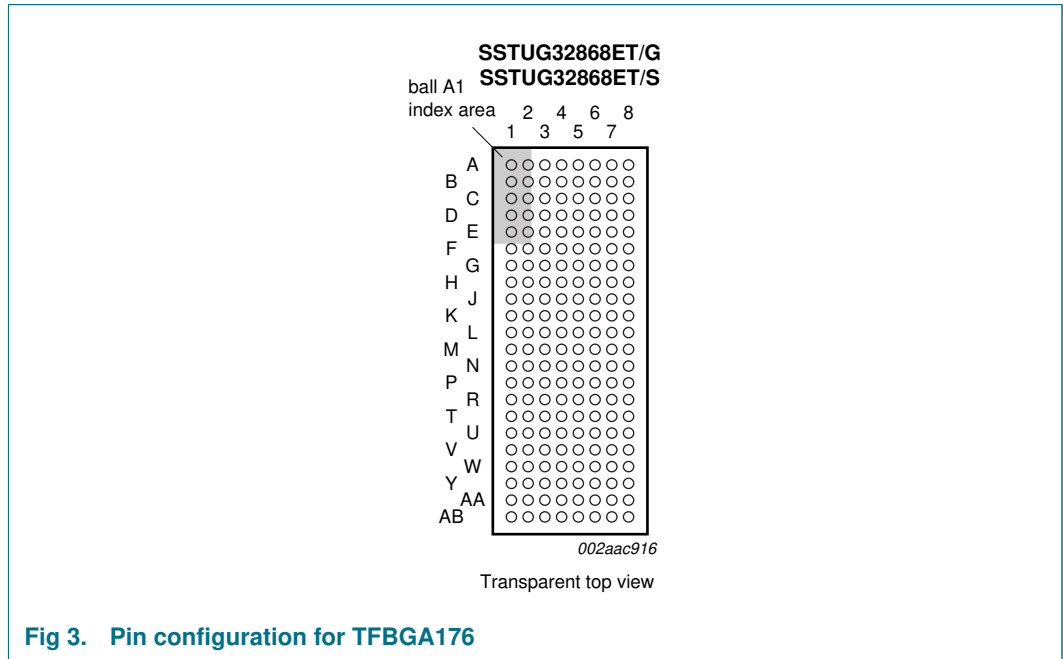

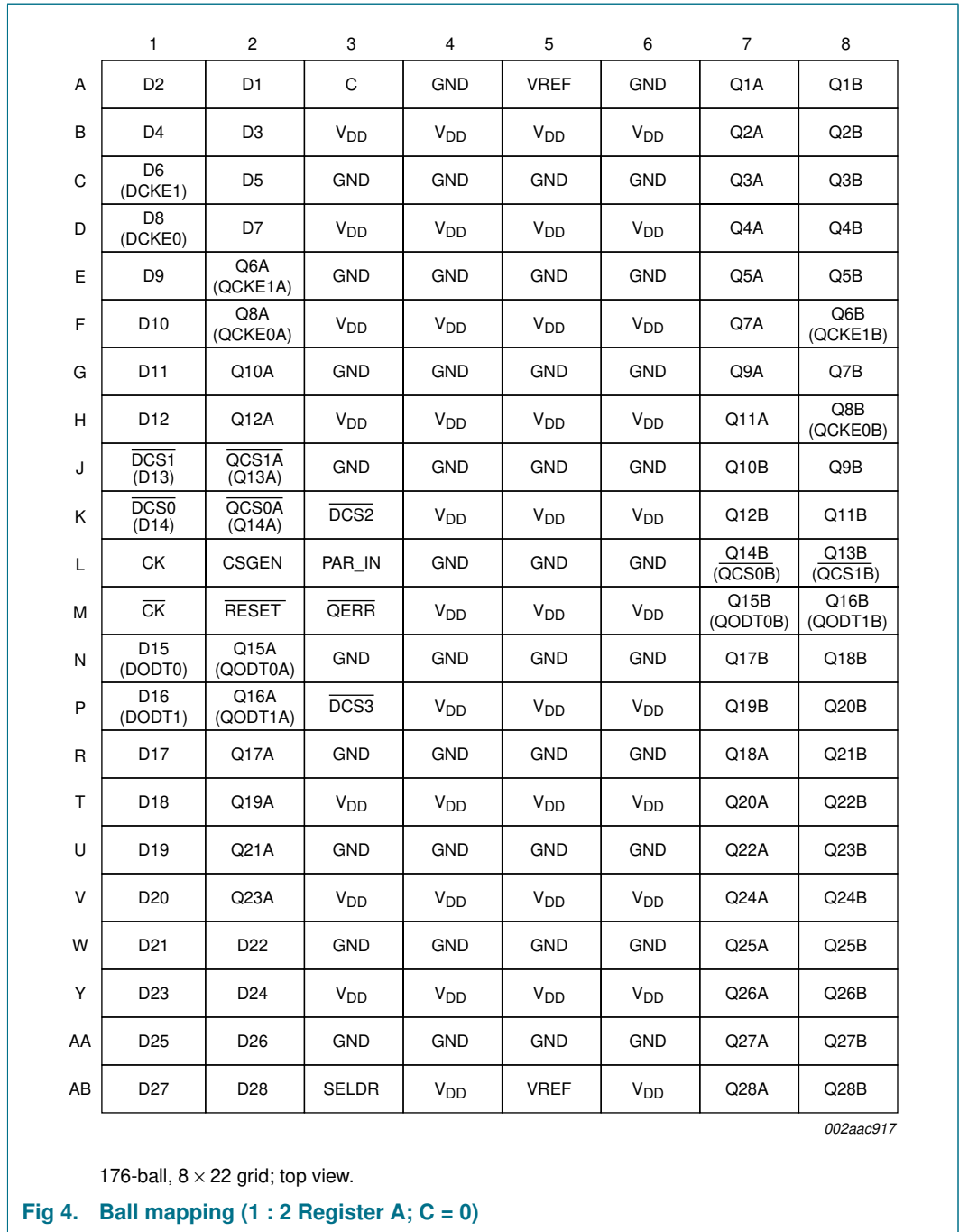

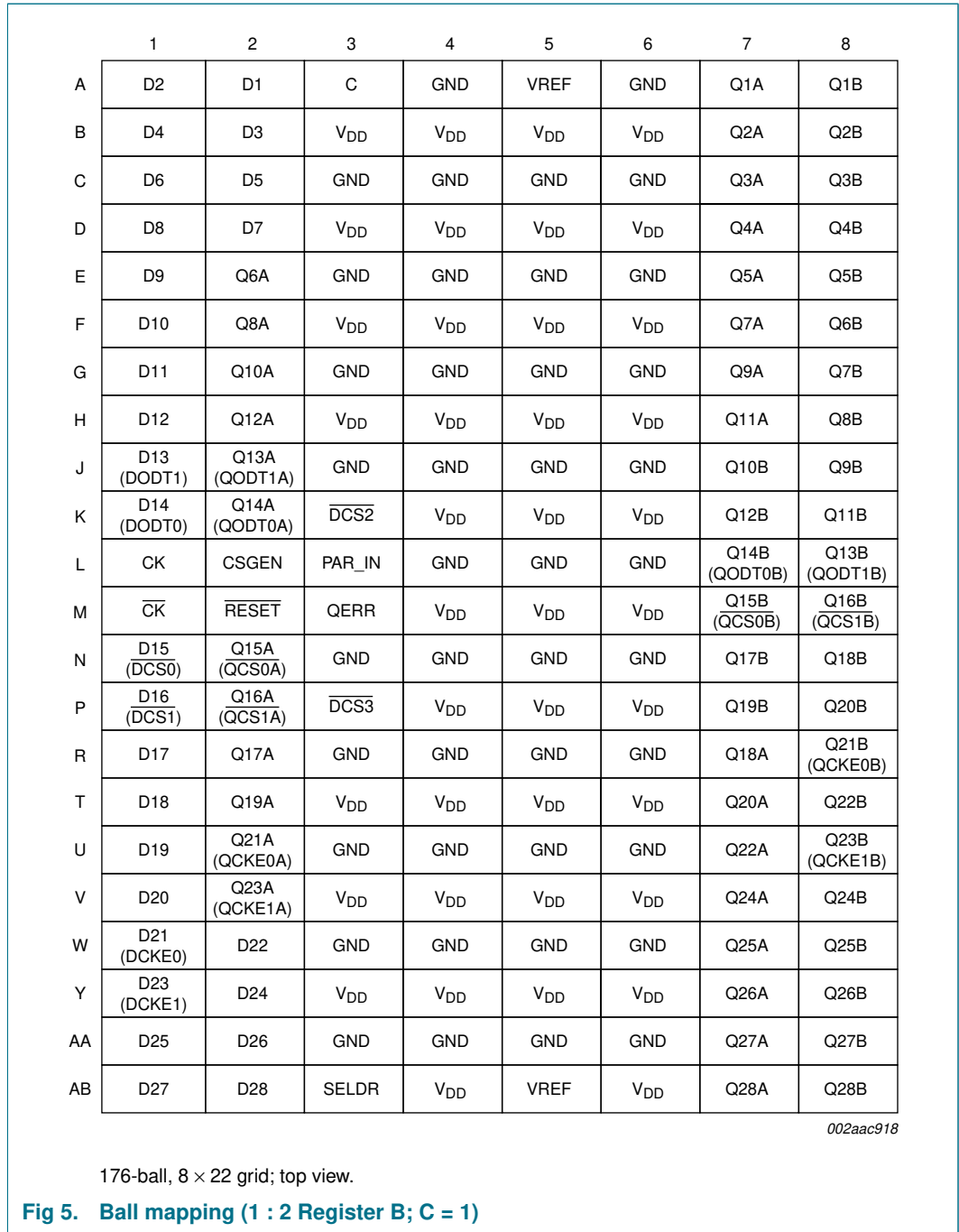

6.2 Pin description

Table 3. Pin description

Symbol	Pin		Type	Description
	1 : 2 Register A (C = 0)	1 : 2 Register B (C = 1)		
Ungated inputs				
DCKE0	D1	W1	SSTL_18	The outputs of this register will not be suspended by the $\overline{DCS0}$ and $\overline{DCS1}$ control.
DCKE1	C1	Y1		
DODT0	N1	K1	SSTL_18	The outputs of this register will not be suspended by the $\overline{DCS0}$ and $\overline{DCS1}$ control.
DODT1	P1	J1		
Chip Select gated inputs				
D1 to D28	A2, A1, B2, B1, C2, C1, D2, D1, E1, F1, G1, H1, N1, P1, R1, T1, U1, V1, W1, W2, Y1, Y2, AA1, AA2, AB1, AB2	A2, A1, B2, B1, C2, C1, D2, D1, E1, F1, G1, H1, J1, K1, N1, P1, R1, T1, U1, V1, W1, W2, Y1, Y2, AA1, AA2, AB1, AB2	SSTL_18	Data inputs, clocked in on the crossing of the rising edge of CK and the falling edge of CK.
Chip Select inputs				
$\overline{DCS0}$	K1	N1	SSTL_18	Chip select inputs. These pins initiate DRAM address/command decodes, and as such at least one will be LOW when a valid address/command is present. The register can be programmed to re-drive all D-inputs (CSGEN = HIGH) only when at least one chip select input is LOW. If CSGEN, $\overline{DCS0}$ and $\overline{DCS1}$ inputs are HIGH, D1 to D28 ^[1] inputs will be disabled.
$\overline{DCS1}$	J1	P1		
$\overline{DCS2}$	K3	K3		
$\overline{DCS3}$	P3	P3		
Configuration control inputs				
C	A3	A3	LVC MOS input	Configuration control inputs; Register A or Register B
Re-driven outputs				
Q1A to Q28A	A7, B7, C7, D7, E7, E2, F7, F2, G7, G2, H7, H2, N2, P2, R2, R7, T2, T7, U2, U7, V2, V7, W7, Y7, AA7, AB7	A7, B7, C7, D7, E7, E2, F7, F2, G7, G2, H7, H2, J2, K2, N2, P2, R2, R7, T2, T7, U2, U7, V2, V7, W7, Y7, AA7, AB7	1.8 V CMOS outputs	Data outputs ^[2] that are suspended by the $\overline{DCS0}$ and $\overline{DCS1}$ control.
Q1B to Q28B	A8, B8, C8, D8, E8, F8, G8, H8, J8, J7, K8, K7, L8, L7, M7, M8, N7, N8, P7, P8, R8, T8, U8, V8, W8, Y8, AA8, AB8	A8, B8, C8, D8, E8, F8, G8, H8, J8, J7, K8, K7, L8, L7, M7, M8, N7, N8, P7, P8, R8, T8, U8, V8, W8, Y8, AA8, AB8		
QCS0A	K2	N2	1.8 V CMOS outputs	Data outputs that will not be suspended by the $\overline{DCS0}$ and $\overline{DCS1}$ control.
QCS0B	L7	M7		
QCS1A	J2	P2		
QCS1B	L8	M8		

Table 3. Pin description ...continued

Symbol	Pin		Type	Description
	1 : 2 Register A (C = 0)	1 : 2 Register B (C = 1)		
QCKE0A	F2	U2	1.8 V CMOS outputs	Data outputs that will not be suspended by the DCS0 and DCS1 control.
QCKE0B	H8	R8		
QCKE1A	E2	V2		
QCKE1B	F8	U8		
QODT0A	N2	K2	1.8 V CMOS outputs	Data outputs that will not be suspended by the DCS0 and DCS1 control.
QODT0B	M7	L7		
QODT1A	P2	J2		
QODT1B	M8	L8		
Output error				
QERR	M3	M3	open-drain output	Output error bit; generated on clock cycle after the corresponding data output.
Parity input				
PAR_IN	L3	L3	SSTL_18	Parity input. Arrives one clock cycle after the corresponding data input.
Program inputs				
CSGEN	L2	L2	LVC MOS input	Chip select gate enable. When HIGH, the D1 to D28[1] inputs will be latched only when at least one chip select input is LOW during the rising edge of the clock. When LOW, the D1 to D28[1] inputs will be latched and re-driven on every rising edge of the clock.
Clock inputs				
CK	L1	L1	differential input	Positive master clock input.
$\overline{\text{CK}}$	M1	M1	differential input	Negative master clock input.
Miscellaneous inputs				
$\overline{\text{RESET}}$	M2	M2	LVC MOS input	Asynchronous reset input. Resets registers and disables VREF data and clock differential-input receivers.
VREF	A5, AB5	A5, AB5	0.9 V nominal	Input reference voltage.
V _{DD}	B3, B4, B5, B6, D3, D4, D5, D6, F3, F4, F5, F6, H3, H4, H5, H6, K4, K5, K6, M4, M5, M6, P4, P5, P6, T3, T4, T5, T6, V3, V4, V5, V6, Y3, Y4, Y5, Y6, AB4, AB6	B3, B4, B5, B6, D3, D4, D5, D6, F3, F4, F5, F6, H3, H4, H5, H6, K4, K5, K6, M4, M5, M6, P4, P5, P6, T3, T4, T5, T6, V3, V4, V5, V6, Y3, Y4, Y5, Y6, AB4, AB6	1.8 V nominal	Power supply voltage.

Table 3. Pin description ...continued

Symbol	Pin		Type	Description
	1 : 2 Register A (C = 0)	1 : 2 Register B (C = 1)		
GND	A4, A6, C3, C4, C5, C6, E3, E4, E5, E6, G3, G4, G5, G6, J3, J4, J5, J6, L4, L5, L6, N3, N4, N5, N6, R3, R4, R5, R6, U3, U4, U5, U6, W3, W4, W5, W6, AA3, AA4, AA5, AA6	A4, A6, C3, C4, C5, C6, E3, E4, E5, E6, G3, G4, G5, G6, J3, J4, J5, J6, L4, L5, L6, N3, N4, N5, N6, R3, R4, R5, R6, U3, U4, U5, U6, W3, W4, W5, W6, AA3, AA4, AA5, AA6	ground input	Ground.
SELDR	AB3	AB3	LVC MOS input with weak pull-up	Selects output drive strength: 'HIGH' for normal drive; 'LOW' for high drive. This pin will default HIGH if left open-circuit (built-in weak pull-up resistor).

- [1] Data inputs = D1 to D5, D7, D9 to D12, D17 to D28 when C = 0.
Data inputs = D1 to D12, D17 to D20, D22, D24 to D28 when C = 1.
- [2] Data outputs = Q1x to Q5x, Q7x, Q9x to Q12x, Q17x to Q28x when C = 0.
Data outputs = Q1x to Q12x, Q17x to Q20x, Q22x, Q24x to Q28x when C = 1.

7. Functional description

7.1 Function table

Table 4. Function table (each flip-flop)

Inputs							Outputs ^[1]			
RESET	DCS0 ^[2]	DCS1 ^[2]	CSGEN	CK	CK	Dn, DODTn, DCKEn	Qn	QCS0x	QCS1x	QODTn, QCKEn
H	L	L	X	↑	↓	L	L	L	L	L
H	L	L	X	↑	↓	H	H	L	L	H
H	L	L	X	L or H	L or H	X	Q ₀	Q ₀	Q ₀	Q ₀
H	L	H	X	↑	↓	L	L	L	H	L
H	L	H	X	↑	↓	H	H	L	H	H
H	L	H	X	L or H	L or H	X	Q ₀	Q ₀	Q ₀	Q ₀
H	H	L	X	↑	↓	L	L	H	L	L
H	H	L	X	↑	↓	H	H	H	L	H
H	H	L	X	L or H	L or H	X	Q ₀	Q ₀	Q ₀	Q ₀
H	H	H	L	↑	↓	L	L	H	H	L
H	H	H	L	↑	↓	H	H	H	H	H
H	H	H	L	L or H	L or H	X	Q ₀	Q ₀	Q ₀	Q ₀
H	H	H	H	↑	↓	L	Q ₀	H	H	L
H	H	H	H	↑	↓	H	Q ₀	H	H	H
H	H	H	H	L or H	L or H	X	Q ₀	Q ₀	Q ₀	Q ₀
L	X or floating	X or floating	X or floating	X or floating	X or floating	X or floating	L	L	L	L

- [1] Q₀ is the previous state of the associated output.
- [2] DCS2 and DCS3 operate identically to DCS0 and DCS1, except they do not have corresponding re-driven (QCS) outputs.

Table 5. Parity and standby function table

Inputs							Output
RESET	DCS0 ^[1]	DCS1 ^[1]	CK	\overline{CK}	Σ of inputs = H (D1 to D28)	PAR_IN ^[2]	QERR ^{[3][4]}
H	L	X	↑	↓	even	L	H
H	L	X	↑	↓	odd	L	L
H	L	X	↑	↓	even	H	L
H	L	X	↑	↓	odd	H	H
H	X	L	↑	↓	even	L	H
H	X	L	↑	↓	odd	L	L
H	X	L	↑	↓	even	H	L
H	X	L	↑	↓	odd	H	H
H	H	H	↑	↓	X	X	\overline{QERR}_0 ^[5]
H	X	X	L or H	L or H	X	X	\overline{QERR}_0
L	X or floating	X or floating	X or floating	X or floating	X	X or floating	H

- [1] $\overline{DCS2}$ and $\overline{DCS3}$ operate identically to $\overline{DCS0}$ and $\overline{DCS1}$ with regard to the parity function.
- [2] PAR_IN arrives one clock cycle after the data to which it applies.
- [3] This transition assumes QERR is HIGH at the crossing of CK going HIGH and \overline{CK} going LOW. If QERR is LOW, it stays latched LOW for two clock cycles or until RESET is driven LOW.
- [4] \overline{QERR}_0 is the previous state of output QERR.
- [5] If $\overline{DCS0}$, $\overline{DCS1}$, $\overline{DCS2}$, $\overline{DCS3}$ and CSGEN are driven HIGH, the device is placed in Low-Power Mode (LPM). If a parity error occurs on the clock cycle before the device enters the LPM and the QERR output is driven LOW, it stays latched LOW for the LPM duration plus two clock cycles or until RESET is driven LOW.

7.2 Functional information

The SSTUG32868 is a 28-bit 1 : 2 configurable registered buffer designed for 1.7 V to 1.9 V V_{DD} operation.

All inputs are compatible with the JEDEC standard for SSTL_18, except the chip-select gate-enable (CSGEN), control (C), and reset (RESET) inputs, which are LVCMOS. All outputs are edge-controlled circuits optimized for unterminated DIMM loads, and meet SSTL_18 specifications, except the open-drain error (QERR) output.

The device supports low-power standby operation. When \overline{RESET} is LOW, the differential input receivers are disabled, and undriven (floating) data, clock, and reference voltage (VREF) inputs are allowed. In addition, when RESET is LOW, all registers are reset and all outputs are forced LOW except QERR. The LVCMOS RESET and C inputs always must be held at a valid logic HIGH or LOW level.

To ensure defined outputs from the register before a stable clock has been supplied, \overline{RESET} must be held in the LOW state during power-up.

In the DDR2 RDIMM application, \overline{RESET} is specified to be completely asynchronous with respect to CK and \overline{CK} . Therefore, no timing relationship can be ensured between the two. When entering reset, the register will be cleared and the data outputs will be driven LOW quickly, relative to the time to disable the differential input receivers. However, when coming out of reset, the register will become active quickly, relative to the time to enable the differential input receivers. As long as the data inputs are LOW, and the clock is stable

during the time from the LOW-to-HIGH transition of $\overline{\text{RESET}}$ until the input receivers are fully enabled, the design of the SSTUG32868 must ensure that the outputs will remain LOW, thus ensuring no glitches on the output.

The SSTUG32868 includes a parity checking function. Parity, which arrives one cycle after the data input to which it applies, is checked on the PAR_IN input of the device. The corresponding $\overline{\text{QERR}}$ output signal for the data inputs is generated two clock cycles after the data, to which the $\overline{\text{QERR}}$ signal applies, is registered.

The SSTUG32868 accepts a parity bit from the memory controller on the parity bit (PAR_IN) input, compares it with the data received on the DIMM-independent D inputs (D1 to D5, D7, D9 to D12, D17 to D28 when C = 0; or D1 to D12, D17 to D20, D22, D24 to D28 when C = 1) and indicates whether a parity error has occurred on the open-drain $\overline{\text{QERR}}$ pin (active LOW). The convention is even parity, that is, valid parity is defined as an even number of ones across the DIMM-independent data inputs combined with the parity input bit. To calculate parity, all DIMM-independent D inputs must be tied to a known logic state.

If an error occurs and the $\overline{\text{QERR}}$ output is driven LOW, it stays latched LOW for a minimum of two clock cycles or until $\overline{\text{RESET}}$ is driven LOW. If two or more consecutive parity errors occur, the $\overline{\text{QERR}}$ output is driven LOW and latched LOW for a clock duration equal to the parity error duration or until $\overline{\text{RESET}}$ is driven LOW. If a parity error occurs on the clock cycle before the device enters the Low-Power Mode (LPM) and the $\overline{\text{QERR}}$ output is driven LOW, then it stays latched LOW for the LPM duration plus two clock cycles or until $\overline{\text{RESET}}$ is driven LOW. The DIMM-dependent signals (DCKE0, DCKE1, DODT0, DODT1, $\overline{\text{DCS0}}$, $\overline{\text{DCS1}}$, $\overline{\text{DCS2}}$ and $\overline{\text{DCS3}}$) are not included in the parity check computation.

The C input controls the pinout configuration from Register A configuration (when LOW) to Register B configuration (when HIGH). The C input should not be switched during normal operation. It should be hard-wired to a valid LOW or HIGH level to configure the register in the desired mode.

The device also supports low-power active operation by monitoring both system chip select ($\overline{\text{DCS0}}$, $\overline{\text{DCS1}}$, $\overline{\text{DCS2}}$ and $\overline{\text{DCS3}}$) and CSGEN inputs and will gate the Qn outputs from changing states when CSGEN, $\overline{\text{DCS0}}$ and $\overline{\text{DCS1}}$ inputs are HIGH. If CSGEN or the $\overline{\text{DCSn}}$ inputs are LOW, the Qn outputs will function normally. Also, if all $\overline{\text{DCSn}}$ inputs are HIGH, the device will gate the $\overline{\text{QERR}}$ output from changing states. If any of the $\overline{\text{DCSn}}$ are LOW, the $\overline{\text{QERR}}$ output will function normally. The $\overline{\text{RESET}}$ input has priority over the $\overline{\text{DCSn}}$ control, and when driven LOW will force the Qn outputs LOW and the $\overline{\text{QERR}}$ output HIGH. If the chip-select control functionality is not desired, then the CSGEN input can be hard-wired to ground (GND), in which case the set-up time requirement for $\overline{\text{DCSn}}$ would be the same as for the other D data inputs. To control the Low-power mode with $\overline{\text{DCSn}}$ only, the CSGEN input should be pulled up to V_{DD} through a pull-up resistor.

The two VREF pins (A5 and AB5) are connected together internally by approximately 150 Ω . However, it is necessary to connect only one of the two VREF pins to the external V_{ref} power supply. An unused VREF pin should be terminated with a V_{ref} coupling capacitor.

The SSTUG32868 is available in a TFGBA176 package.

7.3 Register timing

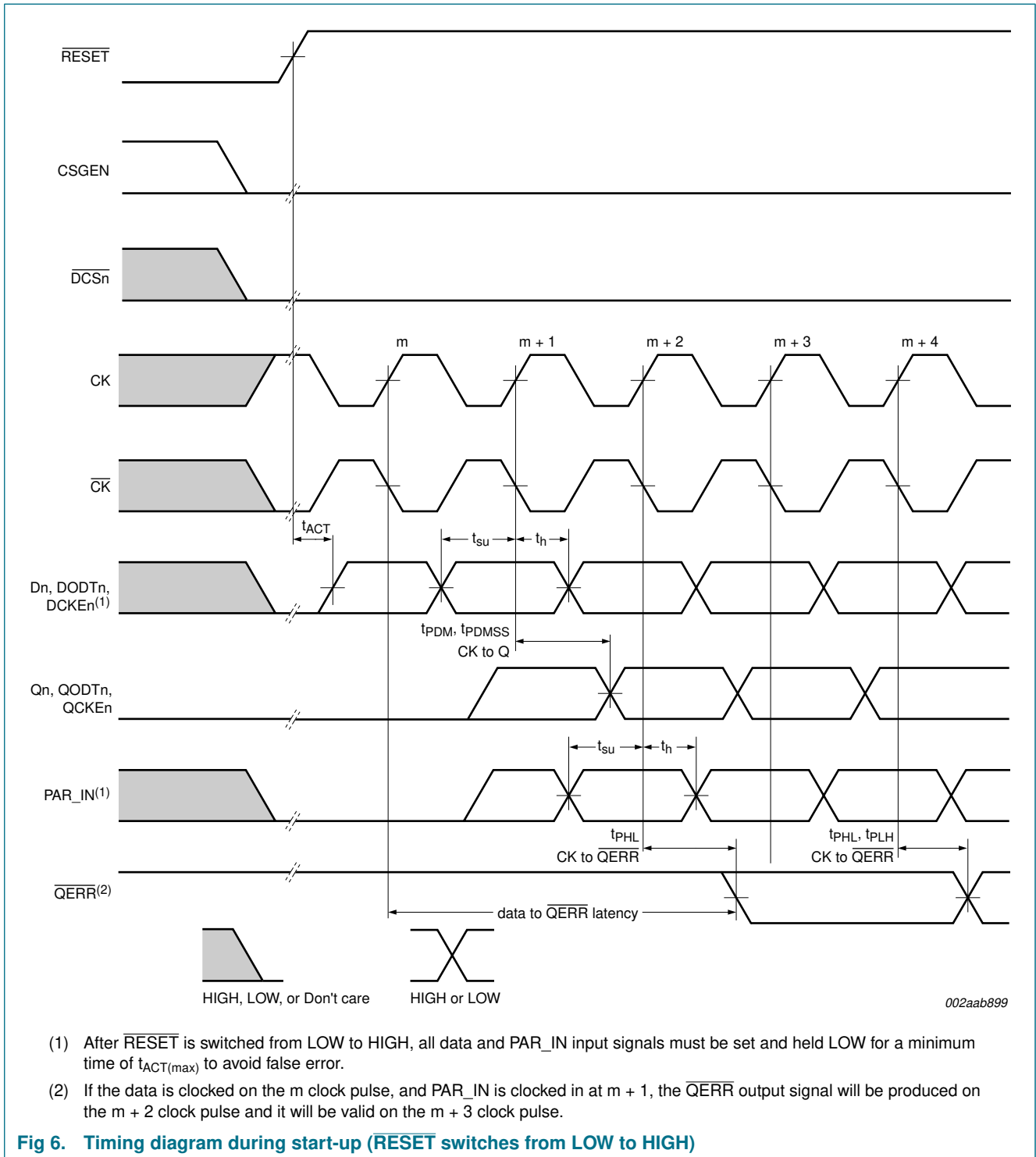

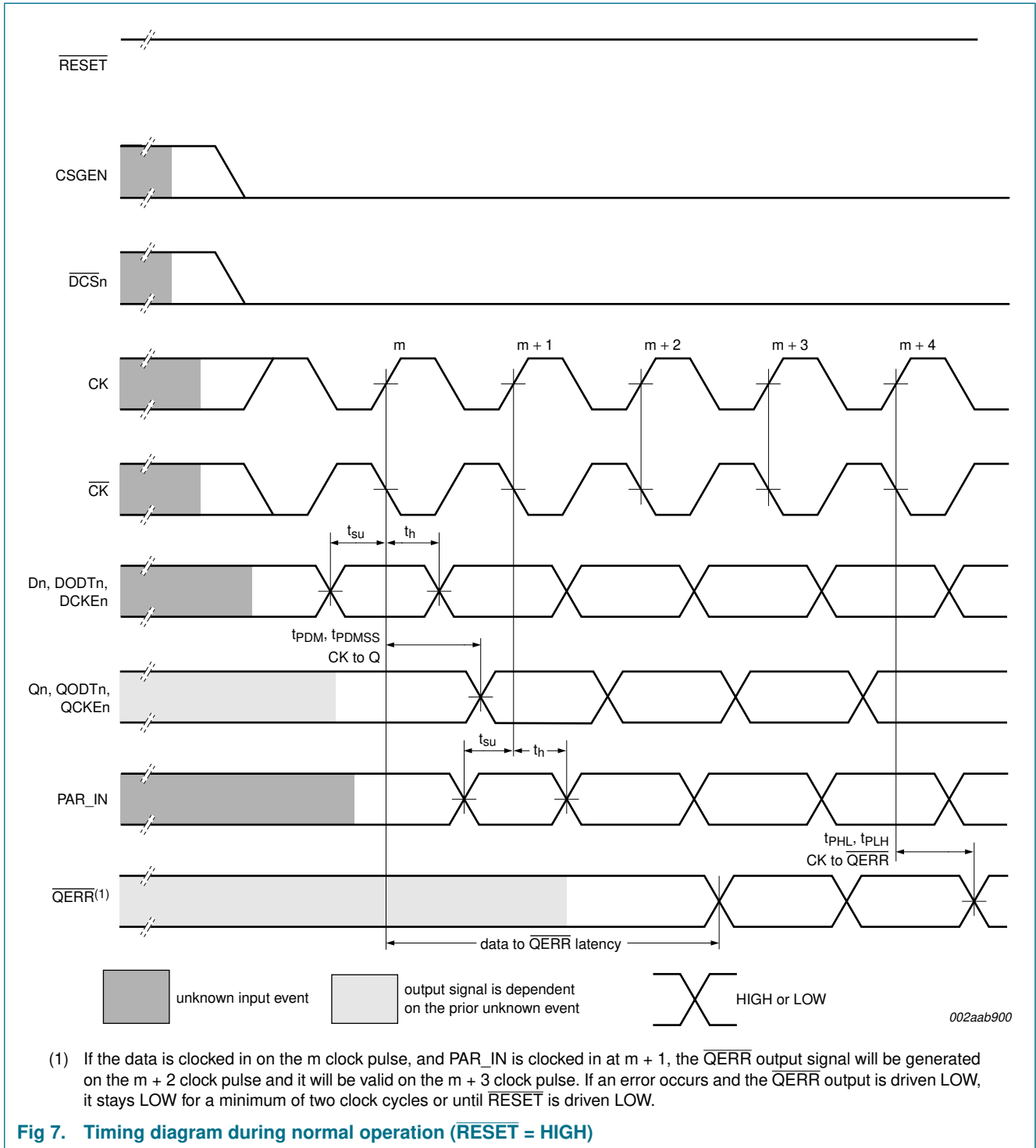

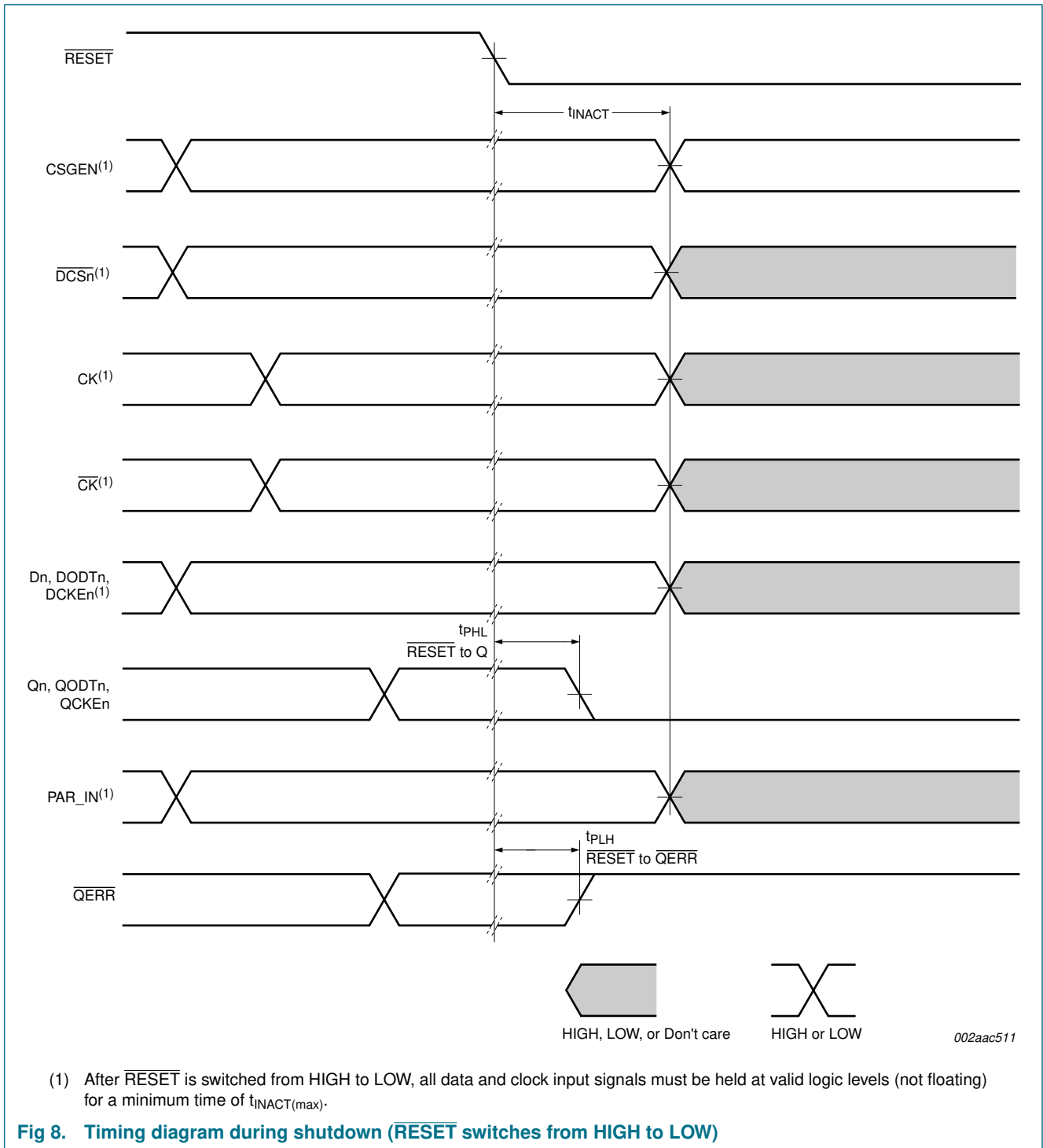

8. Limiting values

Table 6. Limiting values

In accordance with the Absolute Maximum Rating System (IEC 60134).

Symbol	Parameter	Conditions	Min	Max	Unit
V _{DD}	supply voltage		-0.5	+2.5	V
V _I	input voltage	receiver	[1][2] -0.5	+2.5	V
V _O	output voltage	driver	[1][2] -0.5	V _{DD} + 0.5	V
I _{IK}	input clamping current	V _I < 0 V or V _I > V _{DD}	-	±50	mA
I _{OK}	output clamping current	V _O < 0 V or V _O > V _{DD}	-	±50	mA
I _O	output current	continuous; 0 V < V _O < V _{DD}	-	±50	mA
I _{DDC}	continuous current through each V _{DD} or GND pin		-	±100	mA
T _{stg}	storage temperature		-65	+150	°C
V _{esd}	electrostatic discharge voltage	Human Body Model (HBM); 1.5 kΩ; 100 pF	2	-	kV
		Machine Model (MM); 0 Ω; 200 pF	200	-	V

[1] The input and output negative-voltage ratings may be exceeded if the input and output current ratings are observed.

[2] This value is limited to 2.5 V maximum.

9. Recommended operating conditions

Table 7. Recommended operating conditions

Symbol	Parameter	Conditions	Min	Typ	Max	Unit
V _{DD}	supply voltage		1.7	-	2.0	V
V _{ref}	reference voltage		0.49 × V _{DD}	0.50 × V _{DD}	0.51 × V _{DD}	V
V _T	termination voltage		V _{ref} - 0.040	V _{ref}	V _{ref} + 0.040	V
V _I	input voltage		0	-	V _{DD}	V
V _{IH(AC)}	AC HIGH-level input voltage	Dn and PAR_IN inputs	[1] V _{ref} + 0.250	-	-	V
V _{IL(AC)}	AC LOW-level input voltage	Dn and PAR_IN inputs	[1] -	-	V _{ref} - 0.250	V
V _{IH(DC)}	DC HIGH-level input voltage	Dn and PAR_IN inputs	[1] V _{ref} + 0.125	-	-	V
V _{IL(DC)}	DC LOW-level input voltage	Dn and PAR_IN inputs	[1] -	-	V _{ref} - 0.125	V
V _{IH}	HIGH-level input voltage	RESET, CSGEN	[2] 0.65 × V _{DD}	-	-	V
V _{IL}	LOW-level input voltage	RESET, CSGEN	[2] -	-	0.35 × V _{DD}	V
V _{ICR}	common mode input voltage range	CK, CK	0.675	-	1.125	V
V _{ID}	differential input voltage	CK, CK	600	-	-	mV
I _{OH}	HIGH-level output current		-	-	-8	mA
I _{OL}	LOW-level output current		-	-	8	mA
T _{amb}	ambient temperature	operating in free air				
		SSTUG32868ET/G	0	-	+70	°C
		SSTUG32868ET/S	0	-	+85	°C

[1] The differential inputs must not be floating, unless RESET is LOW.

[2] The RESET input of the device must be held at valid logic levels (not floating) to ensure proper device operation.

10. Characteristics

Table 8. Characteristics

Over recommended operating conditions, unless otherwise noted.

Symbol	Parameter	Conditions	Min	Typ	Max	Unit
V _{OH}	HIGH-level output voltage	I _{OH} = -6 mA; V _{DD} = 1.7 V	1.2	-	-	V
V _{OL}	LOW-level output voltage	I _{OL} = 6 mA; V _{DD} = 1.7 V	-	-	0.5	V
I _I	input current	all inputs; V _I = V _{DD} or GND; V _{DD} = 1.9 V	-	-	±5	μA
I _{DD}	supply current	static standby; $\overline{\text{RESET}}$ = GND; V _{DD} = 1.9 V; I _O = 0 mA	-	-	2	mA
		static operating; $\overline{\text{RESET}}$ = V _{DD} ; V _{DD} = 1.9 V; I _O = 0 mA; V _I = V _{IH(AC)} or V _{IL(AC)}	-	-	80	mA
I _{DDD}	dynamic operating current per MHz	clock only; $\overline{\text{RESET}}$ = V _{DD} ; V _I = V _{IH(AC)} or V _{IL(AC)} ; CK and $\overline{\text{CK}}$ switching at 50 % duty cycle. I _O = 0 mA; V _{DD} = 1.8 V	-	16	-	μA
		per each data input (1 : 1 mode); $\overline{\text{RESET}}$ = V _{DD} ; V _I = V _{IH(AC)} or V _{IL(AC)} ; CK and $\overline{\text{CK}}$ switching at 50 % duty cycle. One data input switching at half clock frequency, 50 % duty cycle. I _O = 0 mA; V _{DD} = 1.8 V	-	19	-	μA
		per each data input (1 : 2 mode); $\overline{\text{RESET}}$ = V _{DD} ; V _I = V _{IH(AC)} or V _{IL(AC)} ; CK and $\overline{\text{CK}}$ switching at 50 % duty cycle. One data input switching at half clock frequency, 50 % duty cycle. I _O = 0 mA; V _{DD} = 1.8 V	-	19	-	μA
C _i	input capacitance	Dn, CSGEN, PAR_IN inputs; V _I = V _{ref} ± 250 mV; V _{DD} = 1.8 V	2.5	-	4	pF
		$\overline{\text{DCSn}}$; V _{ICR} = 0.9 V; V _{ID} = 600 mV; V _{DD} = 1.8 V	2.5	-	4	pF
		CK and $\overline{\text{CK}}$; V _{ICR} = 0.9 V; V _{ID} = 600 mV; V _{DD} = 1.8 V	2	-	3	pF
		$\overline{\text{RESET}}$; V _I = V _{DD} or GND; V _{DD} = 1.8 V	3	-	5	pF
Z _o	output impedance	instantaneous	[1]	7	-	Ω
		steady-state	-	53	-	Ω

[1] Instantaneous is defined as within < 2 ns following the output data transition edge.

Table 9. Timing requirements

Over recommended operating conditions, unless otherwise noted.

Symbol	Parameter	Conditions	Min	Typ	Max	Unit
f_{clk}	clock frequency		-	-	450	MHz
t_W	pulse duration	CK, \overline{CK} HIGH or LOW	1	-	-	ns
t_{ACT}	differential inputs active time		[1][2]	-	10	ns
t_{INACT}	differential inputs inactive time		[1][3]	-	15	ns
t_{su}	set-up time	\overline{DCSn} before CK \uparrow , $\overline{CK}\downarrow$	0.6	-	-	ns
		DODTn, DCKEn and Dn before CK \uparrow , $\overline{CK}\downarrow$	0.5	-	-	ns
		PAR_IN before CK \uparrow , $\overline{CK}\downarrow$	0.5	-	-	ns
t_h	hold time	\overline{DCSn} , DODTn, DCKEn and Dn after CK \uparrow , $\overline{CK}\downarrow$	0.4	-	-	ns
		PAR_IN after CK \uparrow , $\overline{CK}\downarrow$	0.4	-	-	ns

[1] This parameter is not necessarily production tested.

[2] VREF must be held at a valid input voltage level, and data inputs must be held LOW for a minimum time of $t_{ACT(max)}$ after \overline{RESET} is taken HIGH.

[3] VREF, data and clock inputs must be held at valid voltage levels (not floating) a minimum time of $t_{INACT(max)}$ after \overline{RESET} is taken LOW.

Table 10. Switching characteristics

Over recommended operating conditions, unless otherwise noted.

Symbol	Parameter	Conditions	Min	Typ	Max	Unit	
$f_{clk(max)}$	maximum clock frequency	input	450	-	-	MHz	
t_{PDM}	peak propagation delay	single bit switching; from CK \uparrow and $\overline{CK}\downarrow$ to Qn	[1]	1.0	-	1.4	ns
t_{PLH}	LOW-to-HIGH propagation delay	from CK \uparrow and $\overline{CK}\downarrow$ to \overline{QERR}	1.2	-	3	ns	
		from $\overline{RESET}\uparrow$ to $\overline{QERR}\downarrow$	-	-	3	ns	
t_{PHL}	HIGH-to-LOW propagation delay	from CK \uparrow and $\overline{CK}\downarrow$ to \overline{QERR}	1	-	2.4	ns	
		from $\overline{RESET}\uparrow$ to Qn \downarrow	-	-	3	ns	
t_{PDMSS}	simultaneous switching peak propagation delay	from CK \uparrow and $\overline{CK}\downarrow$ to Qn	[1]	-	-	1.5	ns

[1] Includes 350 ps of test-load transmission line delay.

Table 11. Output edge rates

Over recommended operating conditions, unless otherwise noted.

Symbol	Parameter	Conditions	Min	Typ	Max	Unit
dV/dt_r	rising edge slew rate	from 20 % to 80 %	1	-	4	V/ns
dV/dt_f	falling edge slew rate	from 80 % to 20 %	1	-	4	V/ns
dV/dt_{Δ}	absolute difference between dV/dt_r and dV/dt_f	(from 20 % to 80 %) or (from 80 % to 20 %)	-	-	1	V/ns

11. Test information

11.1 Parameter measurement information for data output load circuit

$V_{DD} = 1.8 \text{ V} \pm 0.1 \text{ V}$.

All input pulses are supplied by generators having the following characteristics: Pulse Repetition Rate (PRR) $\leq 10 \text{ MHz}$; $Z_0 = 50 \Omega$; input slew rate = $1 \text{ V/ns} \pm 20 \%$, unless otherwise specified.

The outputs are measured one at a time with one transition per measurement.

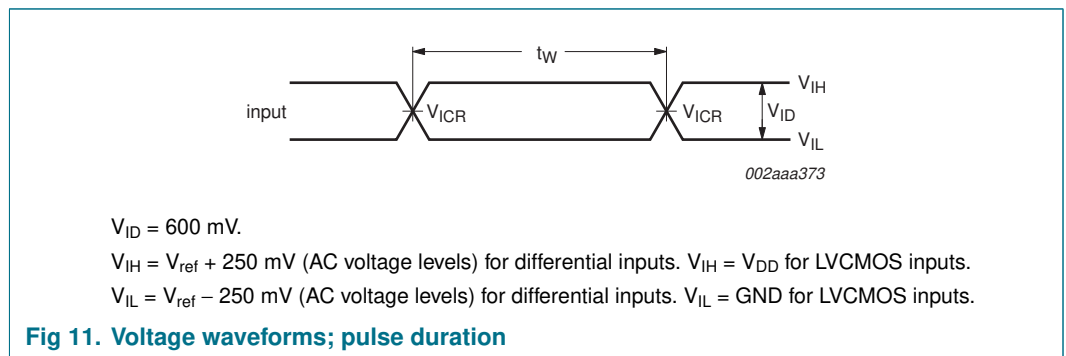
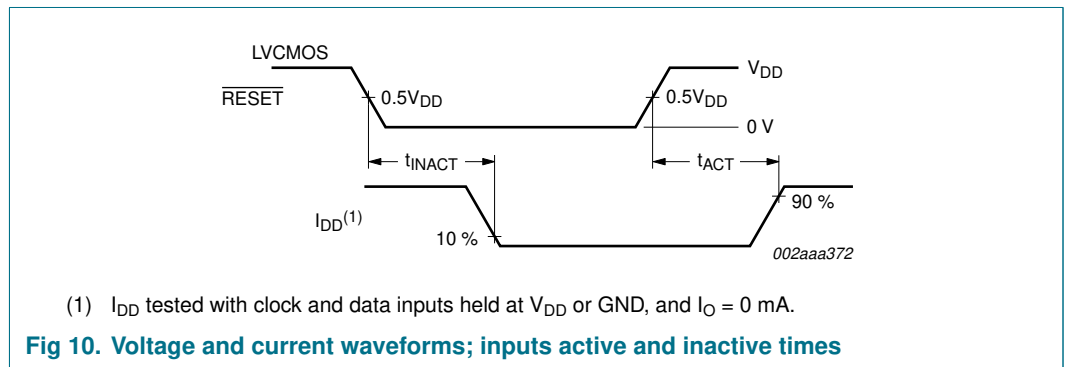
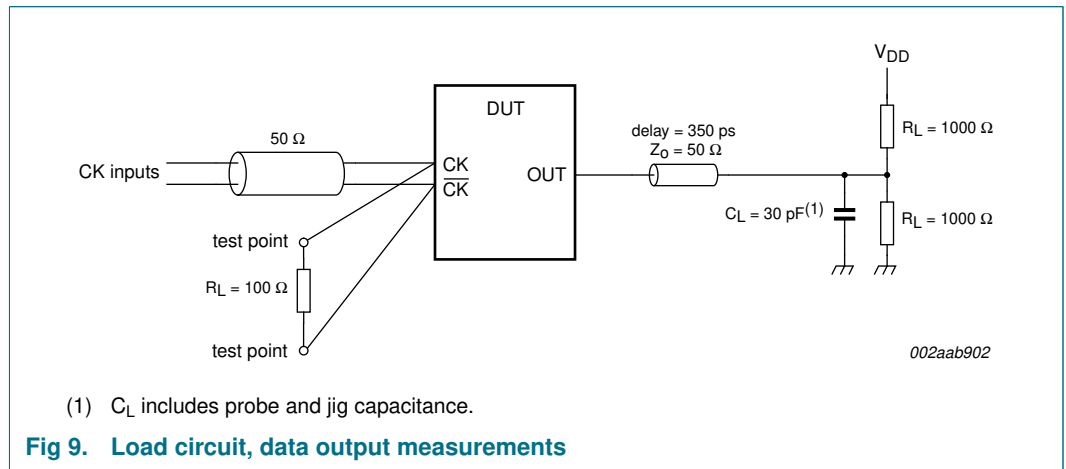

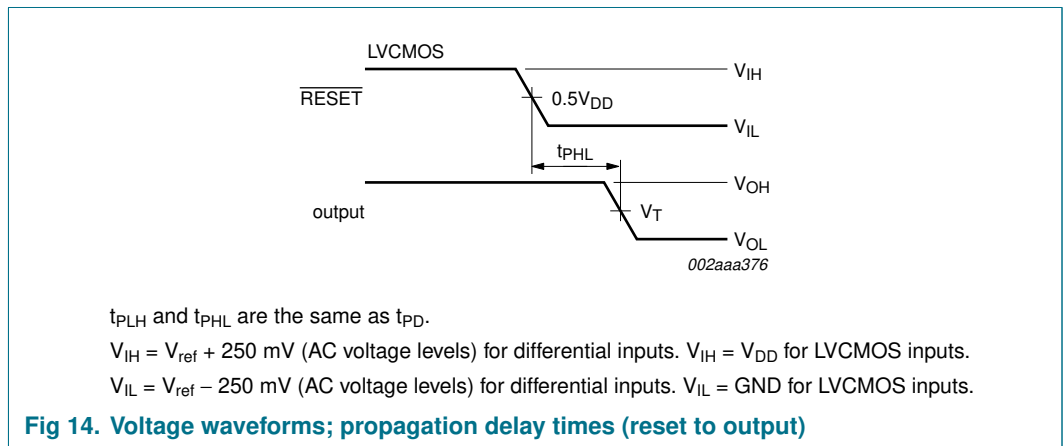
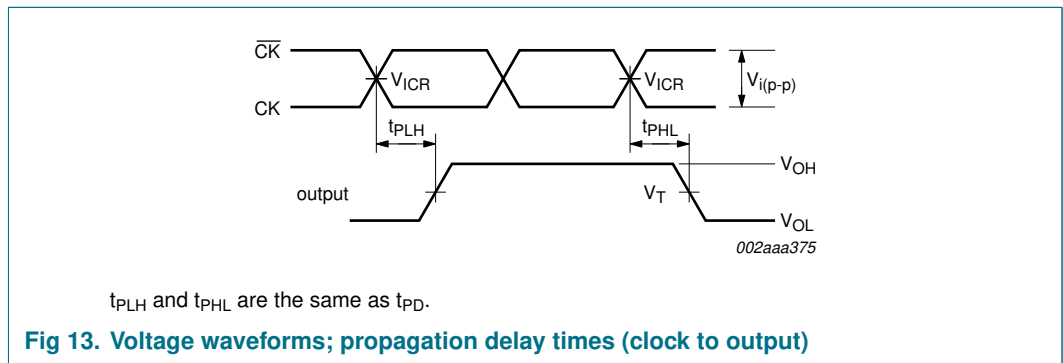
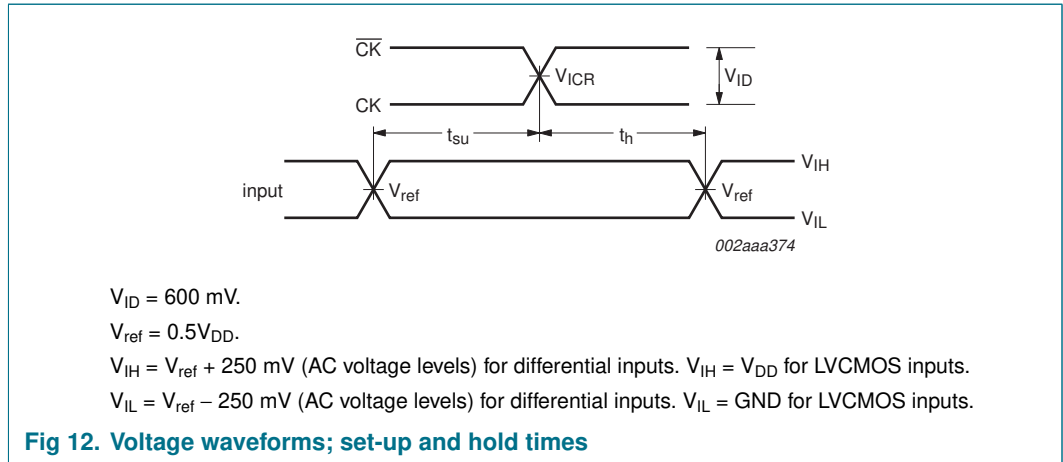

11.2 Data output slew rate measurement

$V_{DD} = 1.8\text{ V} \pm 0.1\text{ V}$.

All input pulses are supplied by generators having the following characteristics: $PRR \leq 10\text{ MHz}$; $Z_0 = 50\ \Omega$; input slew rate = $1\text{ V/ns} \pm 20\%$, unless otherwise specified.

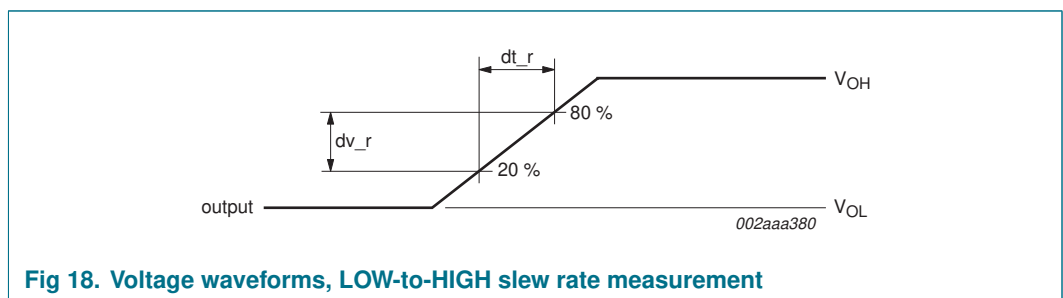
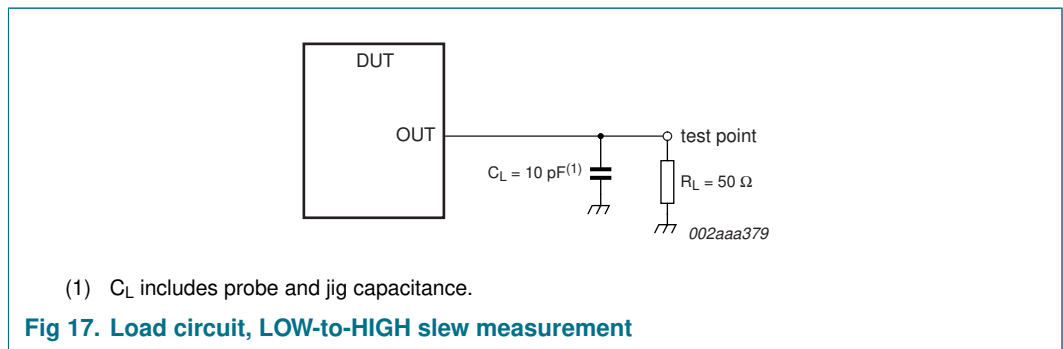
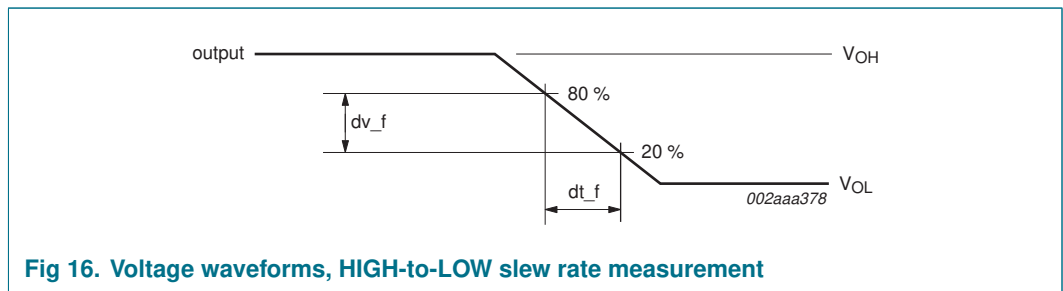
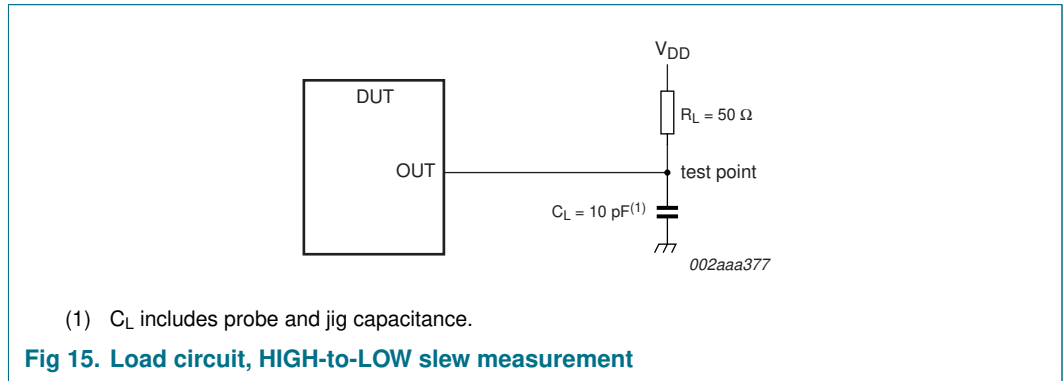

11.3 Error output load circuit and voltage measurement

$V_{DD} = 1.8\text{ V} \pm 0.1\text{ V}$.

All input pulses are supplied by generators having the following characteristics: $PRR \leq 10\text{ MHz}$; $Z_0 = 50\ \Omega$; input slew rate = $1\text{ V/ns} \pm 20\%$, unless otherwise specified.

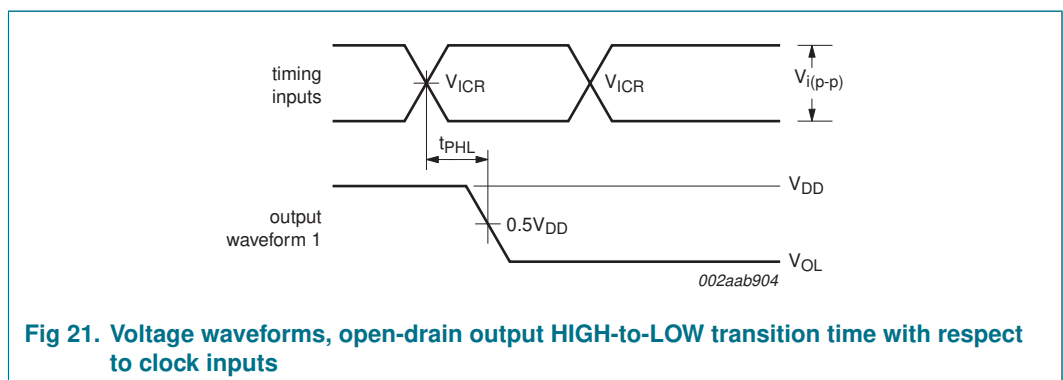
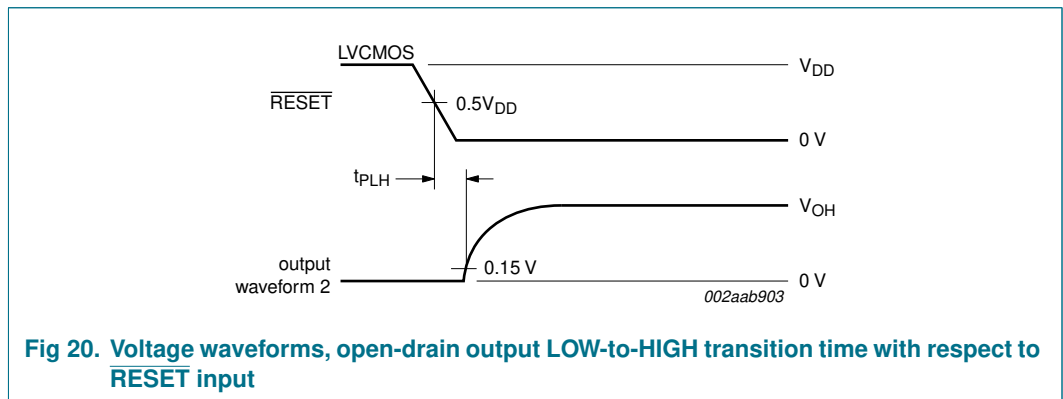
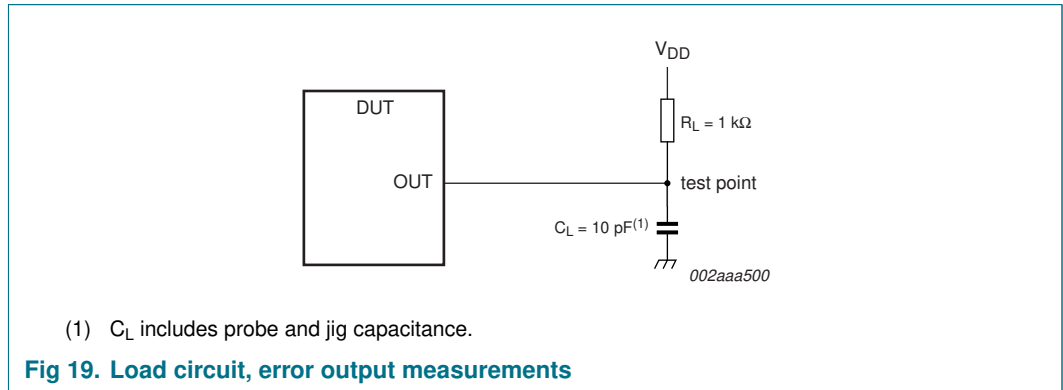

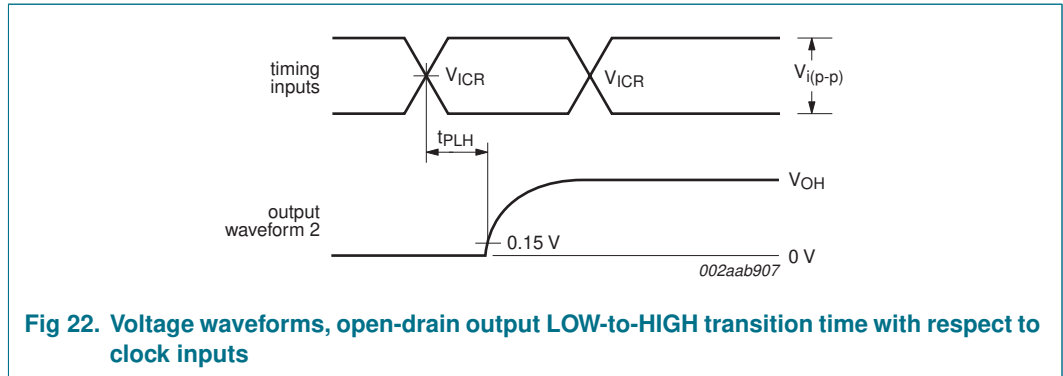

Fig 22. Voltage waveforms, open-drain output LOW-to-HIGH transition time with respect to clock inputs

12. Package outline

TFBGA176: plastic thin fine-pitch ball grid array package; 176 balls; body 6 x 15 x 0.7 mm

SOT932-1

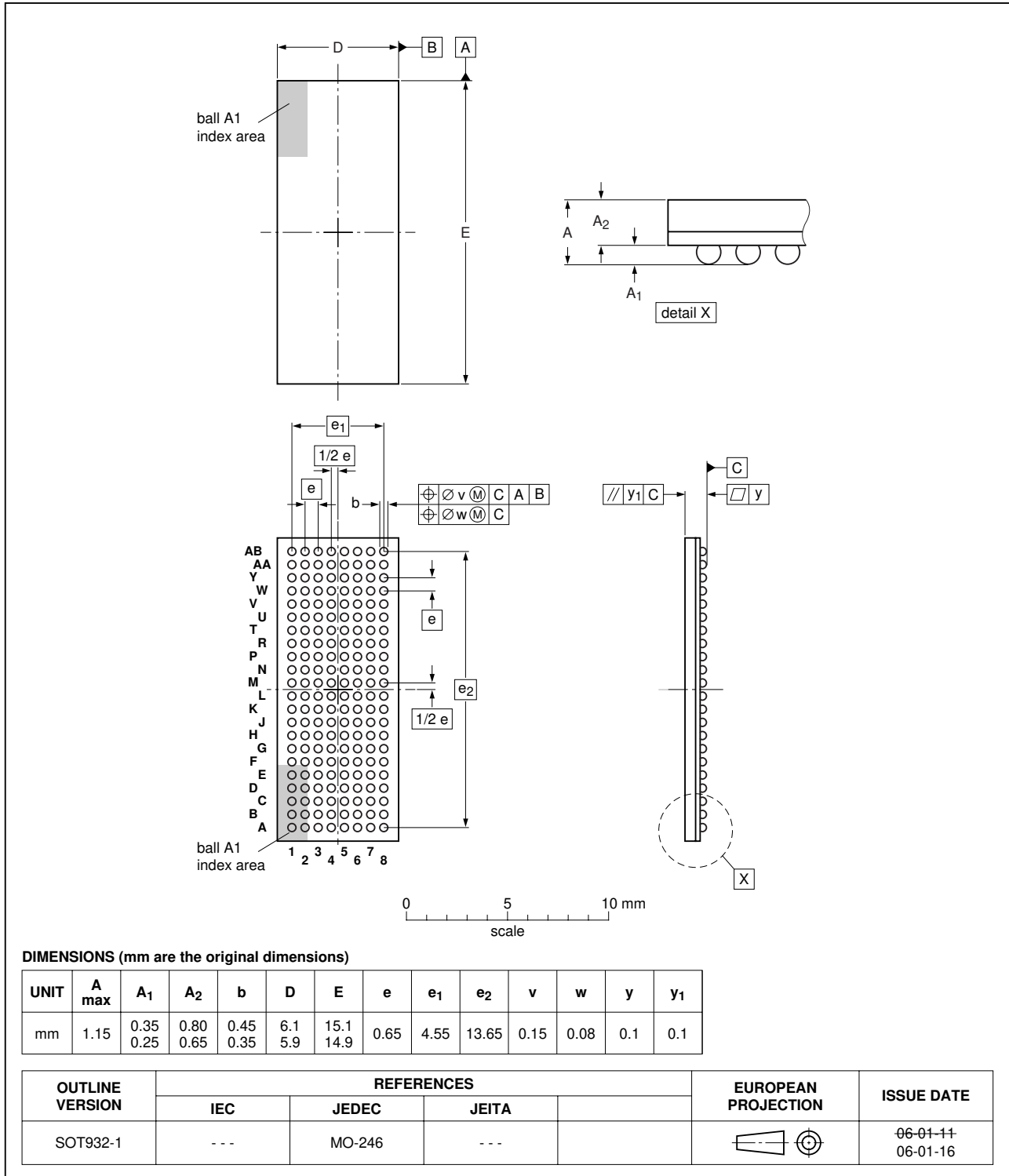

Fig 23. Package outline SOT932-1 (TFBGA176)

13. Soldering

This text provides a very brief insight into a complex technology. A more in-depth account of soldering ICs can be found in Application Note *AN10365 "Surface mount reflow soldering description"*.

13.1 Introduction to soldering

Soldering is one of the most common methods through which packages are attached to Printed Circuit Boards (PCBs), to form electrical circuits. The soldered joint provides both the mechanical and the electrical connection. There is no single soldering method that is ideal for all IC packages. Wave soldering is often preferred when through-hole and Surface Mount Devices (SMDs) are mixed on one printed wiring board; however, it is not suitable for fine pitch SMDs. Reflow soldering is ideal for the small pitches and high densities that come with increased miniaturization.

13.2 Wave and reflow soldering

Wave soldering is a joining technology in which the joints are made by solder coming from a standing wave of liquid solder. The wave soldering process is suitable for the following:

- Through-hole components
- Leaded or leadless SMDs, which are glued to the surface of the printed circuit board

Not all SMDs can be wave soldered. Packages with solder balls, and some leadless packages which have solder lands underneath the body, cannot be wave soldered. Also, leaded SMDs with leads having a pitch smaller than ~0.6 mm cannot be wave soldered, due to an increased probability of bridging.

The reflow soldering process involves applying solder paste to a board, followed by component placement and exposure to a temperature profile. Leaded packages, packages with solder balls, and leadless packages are all reflow solderable.

Key characteristics in both wave and reflow soldering are:

- Board specifications, including the board finish, solder masks and vias
- Package footprints, including solder thieves and orientation
- The moisture sensitivity level of the packages
- Package placement
- Inspection and repair
- Lead-free soldering versus PbSn soldering

13.3 Wave soldering

Key characteristics in wave soldering are:

- Process issues, such as application of adhesive and flux, clinching of leads, board transport, the solder wave parameters, and the time during which components are exposed to the wave
- Solder bath specifications, including temperature and impurities