



Chipsmall Limited consists of a professional team with an average of over 10 year of expertise in the distribution of electronic components. Based in Hongkong, we have already established firm and mutual-benefit business relationships with customers from,Europe,America and south Asia,supplying obsolete and hard-to-find components to meet their specific needs.

With the principle of “Quality Parts,Customers Priority,Honest Operation,and Considerate Service”,our business mainly focus on the distribution of electronic components. Line cards we deal with include Microchip,ALPS,ROHM,Xilinx,Pulse,ON,Everlight and Freescale. Main products comprise IC,Modules,Potentiometer,IC Socket,Relay,Connector.Our parts cover such applications as commercial,industrial, and automotives areas.

We are looking forward to setting up business relationship with you and hope to provide you with the best service and solution. Let us make a better world for our industry!



Contact us

Tel: +86-755-8981 8866 Fax: +86-755-8427 6832

Email & Skype: info@chipsmall.com Web: www.chipsmall.com

Address: A1208, Overseas Decoration Building, #122 Zhenhua RD., Futian, Shenzhen, China



SSTUM32866

1.8 V 25-bit 1 : 1 or 14-bit 1 : 2 configurable registered buffer with parity for DDR2-1G RDIMM applications

Rev. 01 — 29 June 2007

Product data sheet

1. General description

The SSTUM32866 is a 1.8 V configurable register specifically designed for use on DDR2 memory modules requiring a parity checking function. It is defined in accordance with the JEDEC standard for the SSTUM32866 registered buffer. The register is configurable (using configuration pins C0 and C1) to two topologies: 25-bit 1 : 1 or 14-bit 1 : 2, and in the latter configuration can be designated as Register A or Register B on the DIMM.

The SSTUM32866 accepts a parity bit from the memory controller on its parity bit (PAR_IN) input, compares it with the data received on the DIMM-independent D-inputs and indicates whether a parity error has occurred on its open-drain \overline{QERR} pin (active LOW). The convention is even parity, that is, valid parity is defined as an even number of ones across the DIMM-independent data inputs combined with the parity input bit.

The SSTUM32866 is the high-output drive version of SSTUG32866.

The SSTUM32866 is packaged in a 96-ball, 6 × 16 grid, 0.8 mm ball pitch LFBGA package (13.5 mm × 5.5 mm).

2. Features

- Configurable register supporting DDR2 up to 800 MT/s Registered DIMM applications
- Configurable to 25-bit 1 : 1 mode or 14-bit 1 : 2 mode
- Controlled output impedance drivers enable optimal signal integrity and speed
- Meets or exceeds SSTUM32866 JEDEC standard speed performance
- High output drive
- Supports up to 550 MHz clock frequency of operation
- Optimized pinout for high-density DDR2 module design
- Chip-selects minimize power consumption by gating data outputs from changing state
- Supports SSTL_18 data inputs
- Checks parity on the DIMM-independent data inputs
- Partial parity output and input allows cascading of two SSTUM32866s for correct parity error processing
- Differential clock (CK and \overline{CK}) inputs
- Supports LVCMOS switching levels on the control and \overline{RESET} inputs
- Single 1.8 V supply operation (1.7 V to 2.0 V)
- Available in 96-ball, 13.5 mm × 5.5 mm, 0.8 mm ball pitch LFBGA package

3. Applications

- 400 MT/s to 800 MT/s and higher DDR2 registered DIMMs desiring parity checking functionality

4. Ordering information

Table 1. Ordering information

| Type number | Solder process | Package | | |
|----------------|---------------------------------------|---------|---|----------|
| | | Name | Description | Version |
| SSTUM32866EC/G | Pb-free (SnAgCu solder ball compound) | LFBGA96 | plastic low profile fine-pitch ball grid array package; 96 balls; body 13.5 × 5.5 × 1.05 mm | SOT536-1 |
| SSTUM32866EC/S | Pb-free (SnAgCu solder ball compound) | LFBGA96 | plastic low profile fine-pitch ball grid array package; 96 balls; body 13.5 × 5.5 × 1.05 mm | SOT536-1 |

4.1 Ordering options

Table 2. Ordering options

| Type number | Temperature range |
|----------------|-----------------------------------|
| SSTUM32866EC/G | T _{amb} = 0 °C to +70 °C |
| SSTUM32866EC/S | T _{amb} = 0 °C to +85 °C |

5. Functional diagram

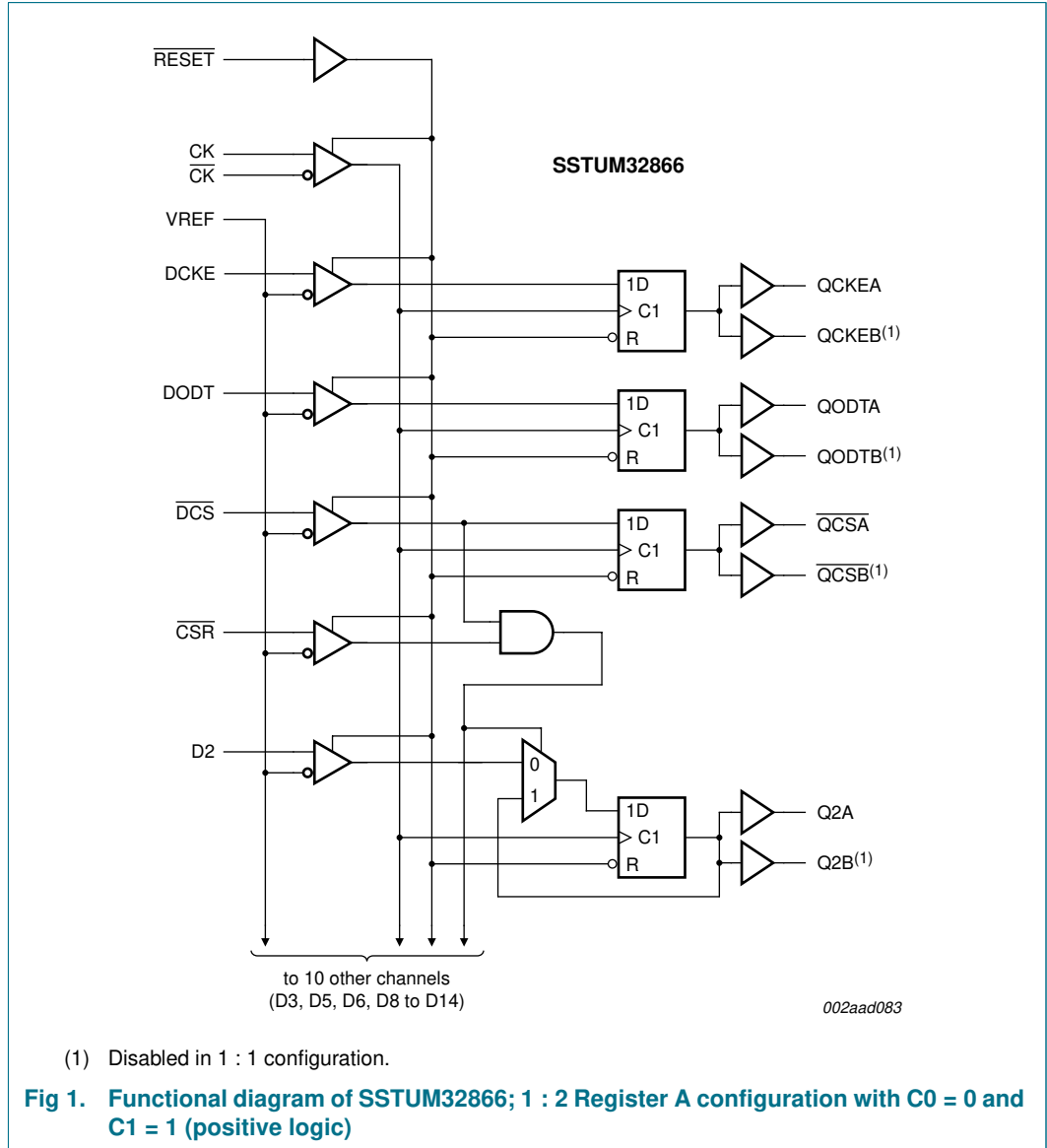

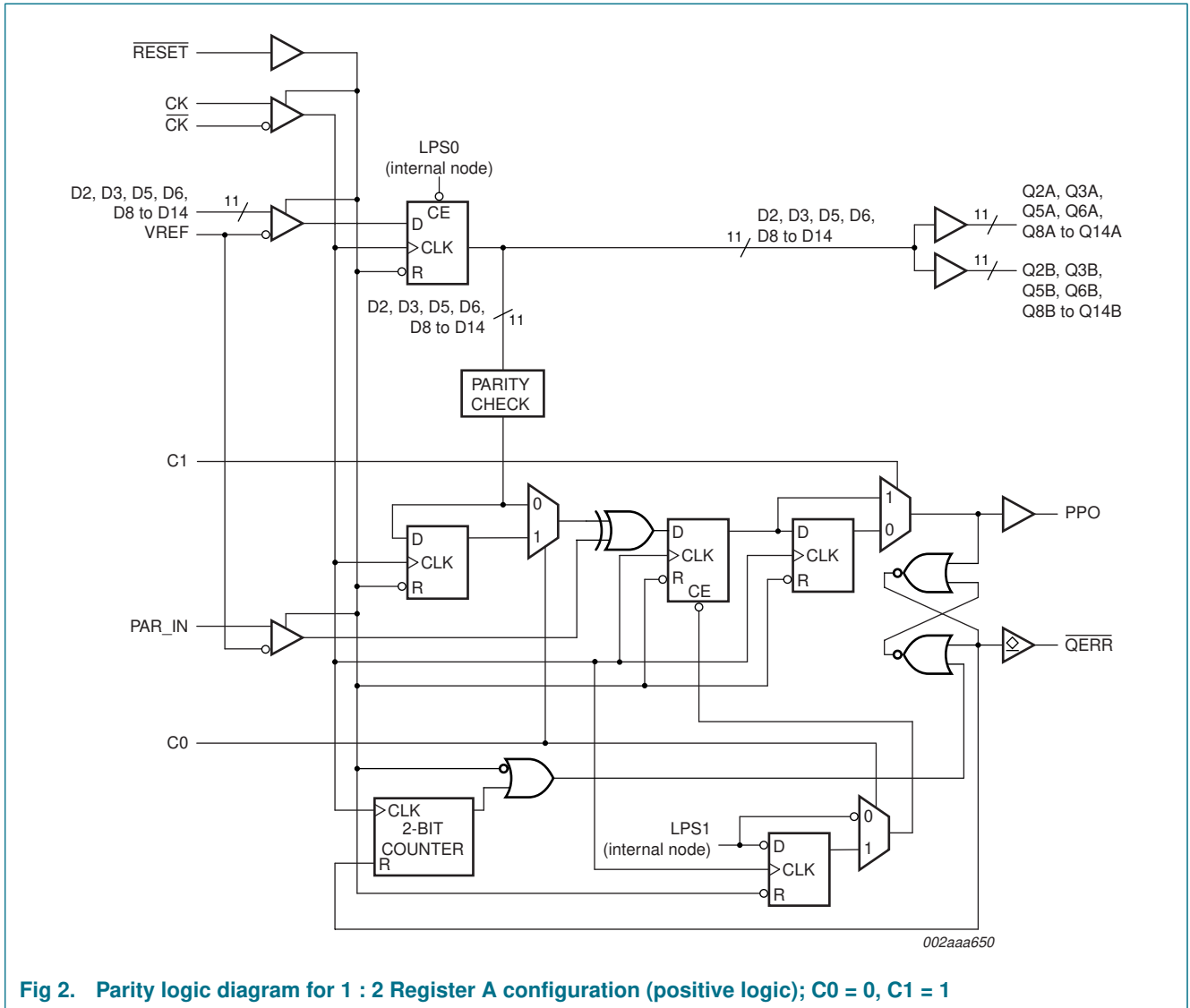
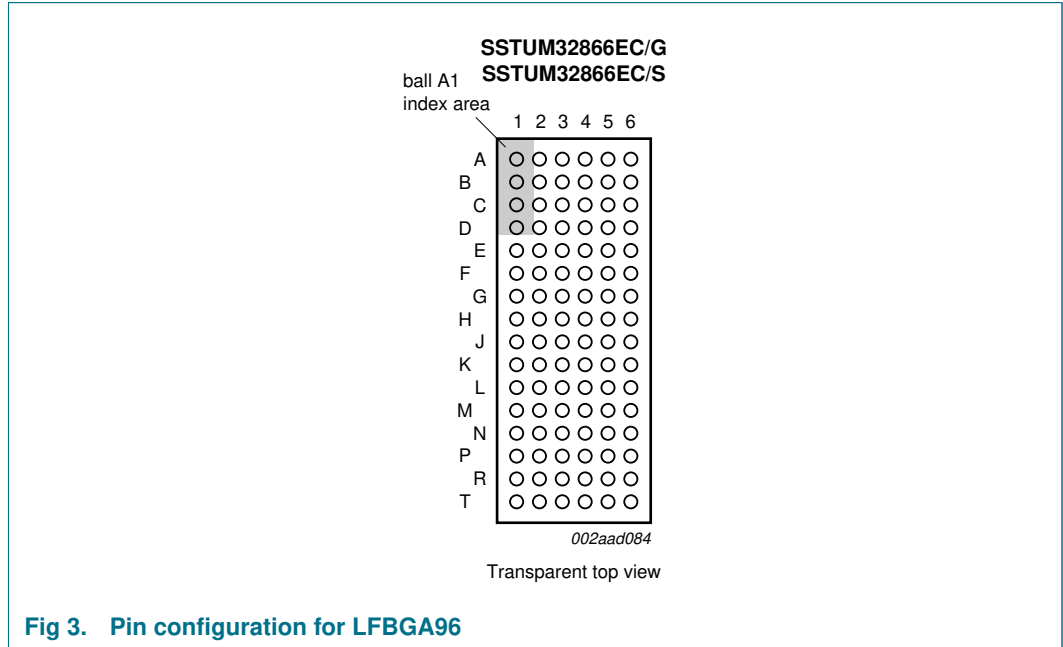

Fig 2. Parity logic diagram for 1 : 2 Register A configuration (positive logic); C0 = 0, C1 = 1

6. Pinning information

6.1 Pinning



| | 1 | 2 | 3 | 4 | 5 | 6 |
|---|-----------------|--------------------|-----------------|-----------------|------------------|------|
| A | DCKE | PPO | VREF | V _{DD} | QCKE | DNU |
| B | D2 | D15 | GND | GND | Q2 | Q15 |
| C | D3 | D16 | V _{DD} | V _{DD} | Q3 | Q16 |
| D | DODT | \overline{QERR} | GND | GND | QODT | DNU |
| E | D5 | D17 | V _{DD} | V _{DD} | Q5 | Q17 |
| F | D6 | D18 | GND | GND | Q6 | Q18 |
| G | PAR_IN | \overline{RESET} | V _{DD} | V _{DD} | C1 | C0 |
| H | CK | \overline{DCS} | GND | GND | \overline{QCS} | DNU |
| J | \overline{CK} | \overline{CSR} | V _{DD} | V _{DD} | n.c. | n.c. |
| K | D8 | D19 | GND | GND | Q8 | Q19 |
| L | D9 | D20 | V _{DD} | V _{DD} | Q9 | Q20 |
| M | D10 | D21 | GND | GND | Q10 | Q21 |
| N | D11 | D22 | V _{DD} | V _{DD} | Q11 | Q22 |
| P | D12 | D23 | GND | GND | Q12 | Q23 |
| R | D13 | D24 | V _{DD} | V _{DD} | Q13 | Q24 |
| T | D14 | D25 | VREF | V _{DD} | Q14 | Q25 |

002aab108

Fig 4. Ball mapping, 1 : 1 register (C0 = 0, C1 = 0)

| | 1 | 2 | 3 | 4 | 5 | 6 |
|---|-----------------|--------------------|-----------------|-----------------|-------------------|-------------------|
| A | DCKE | PPO | VREF | V _{DD} | QCKEA | QCKEB |
| B | D2 | DNU | GND | GND | Q2A | Q2B |
| C | D3 | DNU | V _{DD} | V _{DD} | Q3A | Q3B |
| D | DODT | \overline{QERR} | GND | GND | QODTA | QODTB |
| E | D5 | n.c. | V _{DD} | V _{DD} | Q5A | Q5B |
| F | D6 | n.c. | GND | GND | Q6A | Q6B |
| G | PAR_IN | \overline{RESET} | V _{DD} | V _{DD} | C1 | C0 |
| H | CK | \overline{DCS} | GND | GND | \overline{QCSA} | \overline{QCSB} |
| J | \overline{CK} | \overline{CSR} | V _{DD} | V _{DD} | n.c. | n.c. |
| K | D8 | DNU | GND | GND | Q8A | Q8B |
| L | D9 | DNU | V _{DD} | V _{DD} | Q9A | Q9B |
| M | D10 | DNU | GND | GND | Q10A | Q10B |
| N | D11 | DNU | V _{DD} | V _{DD} | Q11A | Q11B |
| P | D12 | DNU | GND | GND | Q12A | Q12B |
| R | D13 | DNU | V _{DD} | V _{DD} | Q13A | Q13B |
| T | D14 | DNU | VREF | V _{DD} | Q14A | Q14B |

002aab109

Fig 5. Ball mapping, 1 : 2 Register A (C0 = 0, C1 = 1)

| | 1 | 2 | 3 | 4 | 5 | 6 |
|---|-----------------|--------------------|-----------------|-----------------|-------------------|-------------------|
| A | D1 | PPO | VREF | V _{DD} | Q1A | Q1B |
| B | D2 | DNU | GND | GND | Q2A | Q2B |
| C | D3 | DNU | V _{DD} | V _{DD} | Q3A | Q3B |
| D | D4 | \overline{QERR} | GND | GND | Q4A | Q4B |
| E | D5 | DNU | V _{DD} | V _{DD} | Q5A | Q5B |
| F | D6 | DNU | GND | GND | Q6A | Q6B |
| G | PAR_IN | \overline{RESET} | V _{DD} | V _{DD} | C1 | C0 |
| H | CK | \overline{DCS} | GND | GND | \overline{QCSA} | \overline{QCSB} |
| J | \overline{CK} | \overline{CSR} | V _{DD} | V _{DD} | n.c. | n.c. |
| K | D8 | DNU | GND | GND | Q8A | Q8B |
| L | D9 | DNU | V _{DD} | V _{DD} | Q9A | Q9B |
| M | D10 | DNU | GND | GND | Q10A | Q10B |
| N | DODT | DNU | V _{DD} | V _{DD} | QODTA | QODTB |
| P | D12 | DNU | GND | GND | Q12A | Q12B |
| R | D13 | DNU | V _{DD} | V _{DD} | Q13A | Q13B |
| T | DCKE | DNU | VREF | V _{DD} | QCKEA | QCKEB |

002aab110

Fig 6. Ball mapping, 1 : 2 Register B (C0 = 1, C1 = 1)

6.2 Pin description

Table 3. Pin description

| Symbol | Pin | Type | Description |
|---|--|--------------------|--|
| GND | B3, B4, D3, D4, F3, F4, H3, H4, K3, K4, M3, M4, P3, P4 | ground input | ground |
| V _{DD} | A4, C3, C4, E3, E4, G3, G4, J3, J4, L3, L4, N3, N4, R3, R4, T4 | 1.8 V nominal | power supply voltage |
| VREF | A3, T3 | 0.9 V nominal | input reference voltage |
| CK | H1 | differential input | positive master clock input |
| $\overline{\text{CK}}$ | J1 | differential input | negative master clock input |
| C0 | G6 | LVC MOS inputs | Configuration control inputs; Register A or Register B and 1 : 1 mode or 1 : 2 mode select. |
| C1 | G5 | | |
| $\overline{\text{RESET}}$ | G2 | LVC MOS input | Asynchronous reset input (active LOW). Resets registers and disables VREF data and clock. |
| $\overline{\text{CSR}}$ | J2 | SSTL_18 input | Chip select inputs (active LOW). Disables D1 to D25 ^[1] outputs switching when both inputs are HIGH. |
| $\overline{\text{DCS}}$ | H2 | | |
| D1 to D25 | ^[2] | SSTL_18 input | Data input. Clocked in on the crossing of the rising edge of CK and the falling edge of $\overline{\text{CK}}$. |
| DODT | ^[2] | SSTL_18 input | The outputs of this register bit will not be suspended by the $\overline{\text{DCS}}$ and $\overline{\text{CSR}}$ control. |
| DCKE | ^[2] | SSTL_18 input | The outputs of this register bit will not be suspended by the DCS and CSR control. |
| PAR_IN | G1 | SSTL_18 input | Parity input. Arrives one clock cycle after the corresponding data input. |
| Q1 to Q25, Q1A to Q14A, Q1B to Q14B | ^[2] | 1.8 V CMOS outputs | Data outputs that are suspended by the $\overline{\text{DCS}}$ and $\overline{\text{CSR}}$ control. ^[3] |
| PPO | A2 | 1.8 V CMOS output | Partial parity out. Indicates odd parity of inputs D1 to D25. ^[1] |
| $\overline{\text{QCS}}$, $\overline{\text{QCSA}}$, $\overline{\text{QCSB}}$ | ^[2] | 1.8 V CMOS output | Data output that will not be suspended by the $\overline{\text{DCS}}$ and $\overline{\text{CSR}}$ control. |
| QODT, QODTA, QODTB | ^[2] | 1.8 V CMOS output | Data output that will not be suspended by the $\overline{\text{DCS}}$ and $\overline{\text{CSR}}$ control. |
| QCKE, QCKEA, QCKEB | ^[2] | 1.8 V CMOS output | Data output that will not be suspended by the $\overline{\text{DCS}}$ and $\overline{\text{CSR}}$ control. |
| $\overline{\text{QERR}}$ | D2 | open-drain output | Output error bit (active LOW). Generated one clock cycle after the corresponding data output. |
| n.c. | ^[2] | - | Not connected. Ball present but no internal connection to the die. |
| DNU | ^[2] | - | Do not use. Inputs are in standby-equivalent mode and outputs are driven LOW. |

[1] Data inputs = D2, D3, D5, D6, D8 to D25 when C0 = 0 and C1 = 0.
 Data inputs = D2, D3, D5, D6, D8 to D14 when C0 = 0 and C1 = 1.
 Data inputs = D1 to D6, D8 to D10, D12, D13 when C0 = 1 and C1 = 1.

[2] Depends on configuration. See [Figure 4](#), [Figure 5](#), and [Figure 6](#) for ball number.

- [3] Data outputs = Q2, Q3, Q5, Q6, Q8 to Q25 when C0 = 0 and C1 = 0.
 Data outputs = Q2, Q3, Q5, Q6, Q8 to Q14 when C0 = 0 and C1 = 1.
 Data outputs = Q1 to Q6, Q8 to Q10, Q12, Q13 when C0 = 1 and C1 = 1.

7. Functional description

The SSTUM32866 is a 25-bit 1 : 1 or 14-bit 1 : 2 configurable registered buffer with parity, designed for 1.7 V to 2.0 V V_{DD} operation.

All clock and data inputs are compatible with the JEDEC standard for SSTL_18. The control and reset (\overline{RESET}) inputs are LVCMOS. All data outputs are 1.8 V CMOS drivers that have been optimized to drive the DDR2 DIMM load, and meet SSTL_18 specifications. The error (\overline{QERR}) output is 1.8 V open-drain driver.

The SSTUM32866 operates from a differential clock (CK and \overline{CK}). Data are registered at the crossing of CK going HIGH, and \overline{CK} going LOW.

The C0 input controls the pinout configuration for the 1 : 2 pinout from A configuration (when LOW) to B configuration (when HIGH). The C1 input controls the pinout configuration from 25-bit 1 : 1 (when LOW) to 14-bit 1 : 2 (when HIGH).

The SSTUM32866 accepts a parity bit from the memory controller on its parity bit (PAR_IN) input, compares it with the data received on the DIMM-independent D-inputs and indicates whether a parity error has occurred on its open-drain \overline{QERR} pin (active LOW). The convention is even parity, that is, valid parity is defined as an even number of ones across the DIMM-independent data inputs combined with the parity input bit.

When used as a single device, the C0 and C1 inputs are tied LOW. In this configuration, parity is checked on the PAR_IN input which arrives one cycle after the input data to which it applies. The Partial-Parity-Out (PPO) and \overline{QERR} signals are produced three cycles after the corresponding data inputs.

When used in pairs, the C0 input of the first register is tied LOW and the C0 input of the second register is tied HIGH. The C1 input of both registers are tied HIGH. Parity, which arrives one cycle after the data input to which it applies, is checked on the PAR_IN input of the first device. The PPO and \overline{QERR} signals are produced on the second device three clock cycles after the corresponding data inputs. The PPO output of the first register is cascaded to the PAR_IN of the second register. The \overline{QERR} output of the first register is left floating and the valid error information is latched on the \overline{QERR} output of the second register.

If an error occurs and the \overline{QERR} output is driven LOW, it stays latched LOW for two clock cycles or until \overline{RESET} is driven LOW. The DIMM-dependent signals (DCKE, \overline{DCS} , DODT, and \overline{CSR}) are not included in the parity check computation.

The device supports low-power standby operation. When \overline{RESET} is LOW, the differential input receivers are disabled, and undriven (floating) data, clock and reference voltage (VREF) inputs are allowed. In addition, when \overline{RESET} is LOW all registers are reset, and all outputs are forced LOW. The LVCMOS \overline{RESET} input must always be held at a valid logic HIGH or LOW level.

The device also supports low-power active operation by monitoring both system chip select (\overline{DCS} and \overline{CSR}) inputs and will gate the Qn and PPO outputs from changing states when both \overline{DCS} and \overline{CSR} inputs are HIGH. If either \overline{DCS} or \overline{CSR} input is LOW, the Qn and PPO outputs will function normally. The \overline{RESET} input has priority over the \overline{DCS} and \overline{CSR} control and when driven LOW will force the Qn and PPO outputs LOW, and the \overline{QERR} output HIGH. If the \overline{DCS} control functionality is not desired, then the \overline{CSR} input can be hard-wired to ground, in which case, the setup time requirement for \overline{DCS} would be the same as for the other Dn data inputs. To control the low-power mode with \overline{DCS} only, then the \overline{CSR} input should be pulled up to V_{DD} through a pull-up resistor.

To ensure defined outputs from the register before a stable clock has been supplied, \overline{RESET} must be held in the LOW state during power-up.

In the DDR2 RDIMM application, \overline{RESET} is specified to be completely asynchronous with respect to CK and \overline{CK} . Therefore, no timing relationship can be guaranteed between the two. When entering reset, the register will be cleared and the Qn outputs will be driven LOW quickly, relative to the time to disable the differential input receivers. However, when coming out of reset, the register will become active quickly, relative to the time to enable the differential input receivers. As long as the data inputs are LOW, and the clock is stable during the time from the LOW-to-HIGH transition of \overline{RESET} until the input receivers are fully enabled, the design of the SSTUM32866 must ensure that the outputs will remain LOW, thus ensuring no glitches on the output.

7.1 Function table

Table 4. Function table (each flip-flop)

L = LOW voltage level; H = HIGH voltage level; X = don't care; \uparrow = LOW-to-HIGH transition; \downarrow = HIGH-to-LOW transition.

| Inputs | | | | | | Outputs ^[1] | | |
|--------|---------------|---------------|---------------|-----------------|------------------|------------------------|------------------|----------------|
| RESET | DCS | CSR | CK | \overline{CK} | Dn, DODTn, DCKEn | Qn | \overline{QCS} | QODT, QCKE |
| H | L | L | \uparrow | \downarrow | L | L | L | L |
| H | L | L | \uparrow | \downarrow | H | H | L | H |
| H | L | L | L or H | L or H | X | Q ₀ | Q ₀ | Q ₀ |
| H | L | H | \uparrow | \downarrow | L | L | L | L |
| H | L | H | \uparrow | \downarrow | H | H | L | H |
| H | L | H | L or H | L or H | X | Q ₀ | Q ₀ | Q ₀ |
| H | H | L | \uparrow | \downarrow | L | L | H | L |
| H | H | L | \uparrow | \downarrow | H | H | H | H |
| H | H | L | L or H | L or H | X | Q ₀ | Q ₀ | Q ₀ |
| H | H | H | \uparrow | \downarrow | L | Q ₀ | H | L |
| H | H | H | \uparrow | \downarrow | H | Q ₀ | H | H |
| H | H | H | L or H | L or H | X | Q ₀ | Q ₀ | Q ₀ |
| L | X or floating | X or floating | X or floating | X or floating | X or floating | L | L | L |

[1] Q₀ is the previous state of the associated output.

Table 5. Parity and standby function table

L = LOW voltage level; H = HIGH voltage level; X = don't care; ↑ = LOW-to-HIGH transition; ↓ = HIGH-to-LOW transition.

| Inputs | | | | | | | Outputs ^[1] | |
|--------|---------------|---------------|---------------|---------------|-----------------------------|-----------------------|------------------------|---------------------|
| RESET | DCS | CSR | CK | CK | Σ of inputs = H (D1 to D25) | PAR_IN ^[2] | PPO ^[3] | QERR ^[4] |
| H | L | X | ↑ | ↓ | even | L | L | H |
| H | L | X | ↑ | ↓ | odd | L | H | L |
| H | L | X | ↑ | ↓ | even | H | H | L |
| H | L | X | ↑ | ↓ | odd | H | L | H |
| H | H | L | ↑ | ↓ | even | L | L | H |
| H | H | L | ↑ | ↓ | odd | L | H | L |
| H | H | L | ↑ | ↓ | even | H | H | L |
| H | H | L | ↑ | ↓ | odd | H | L | H |
| H | H | H | ↑ | ↓ | X | X | PPO ₀ | QERR ₀ |
| H | X | X | L or H | L or H | X | X | PPO ₀ | QERR ₀ |
| L | X or floating | X or floating | X or floating | X or floating | X or floating | X or floating | L | H |

- [1] PPO₀ is the previous state of output PPO; QERR₀ is the previous state of output QERR.
- [2] Data inputs = D2, D3, D5, D6, D8 to D25 when C0 = 0 and C1 = 0.
Data inputs = D2, D3, D5, D6, D8 to D14 when C0 = 0 and C1 = 1.
Data inputs = D1 to D6, D8 to D10, D12, D13 when C0 = 1 and C1 = 1.
- [3] PAR_IN arrives one clock cycle (C0 = 0), or two clock cycles (C0 = 1), after the data to which it applies.
- [4] This condition assumes QERR is HIGH at the crossing of CK going HIGH and CK going LOW. If QERR is LOW, it stays latched LOW for two clock cycles or until RESET is driven LOW.

8. Limiting values

Table 6. Limiting values

In accordance with the Absolute Maximum Rating System (IEC 60134).

| Symbol | Parameter | Conditions | Min | Max | Unit |
|------------------|--|--|---------------------|--------------------------------------|------|
| V _{DD} | supply voltage | | -0.5 | +2.5 | V |
| V _I | input voltage | receiver | -0.5 ^[1] | +2.5 ^[2] | V |
| V _O | output voltage | driver | -0.5 ^[1] | V _{DD} + 0.5 ^[2] | V |
| I _{IK} | input clamping current | V _I < 0 V or V _I > V _{DD} | - | -50 | mA |
| I _{OK} | output clamping current | V _O < 0 V or V _O > V _{DD} | - | ±50 | mA |
| I _O | output current | continuous; 0 V < V _O < V _{DD} | - | ±50 | mA |
| I _{DDC} | continuous current through each V _{DD} or GND pin | | - | ±100 | mA |
| T _{stg} | storage temperature | | -65 | +150 | °C |
| V _{esd} | electrostatic discharge voltage | Human Body Model (HBM); 1.5 kΩ; 100 pF | 2 | - | kV |
| | | Machine Model (MM); 0 Ω; 200 pF | 200 | - | V |

- [1] The input and output negative voltage ratings may be exceeded if the input and output clamping current ratings are observed.
- [2] This value is limited to 2.5 V maximum.

9. Recommended operating conditions

Table 7. Recommended operating conditions

| Symbol | Parameter | Conditions | Min | Typ | Max | Unit |
|--------------|---------------------------------|---|--------------------------|----------------------|----------------------|------|
| V_{DD} | supply voltage | | 1.7 | - | 2.0 | V |
| V_{ref} | reference voltage | | $0.49 \times V_{DD}$ | $0.50 \times V_{DD}$ | $0.51 \times V_{DD}$ | V |
| V_T | termination voltage | | $V_{ref} - 0.040$ | V_{ref} | $V_{ref} + 0.040$ | V |
| V_I | input voltage | | 0 | - | V_{DD} | V |
| $V_{IH(AC)}$ | AC HIGH-level input voltage | data (Dn), \overline{CSR} , and PAR_IN inputs | $V_{ref} + 0.250$ | - | - | V |
| $V_{IL(AC)}$ | AC LOW-level input voltage | data (Dn), \overline{CSR} , and PAR_IN inputs | - | - | $V_{ref} - 0.250$ | V |
| $V_{IH(DC)}$ | DC HIGH-level input voltage | data (Dn), \overline{CSR} , and PAR_IN inputs | $V_{ref} + 0.125$ | - | - | V |
| $V_{IL(DC)}$ | DC LOW-level input voltage | data (Dn), \overline{CSR} , and PAR_IN inputs | - | - | $V_{ref} - 0.125$ | V |
| V_{IH} | HIGH-level input voltage | \overline{RESET} , Cn | [1] $0.65 \times V_{DD}$ | - | - | V |
| V_{IL} | LOW-level input voltage | \overline{RESET} , Cn | [1] - | - | $0.35 \times V_{DD}$ | V |
| V_{ICR} | common mode input voltage range | CK, \overline{CK} | [2] 0.675 | - | 1.125 | V |
| V_{ID} | differential input voltage | CK, \overline{CK} | [2] 600 | - | - | mV |
| I_{OH} | HIGH-level output current | | - | - | -8 | mA |
| I_{OL} | LOW-level output current | | - | - | 8 | mA |
| T_{amb} | ambient temperature | operating in free air | | | | |
| | | SSTUM32866EC/G | 0 | - | 70 | °C |
| | | SSTUM32866EC/S | 0 | - | 85 | °C |

[1] The \overline{RESET} and Cn inputs of the device must be held at valid levels (not floating) to ensure proper device operation.

[2] The differential inputs must not be floating, unless \overline{RESET} is LOW.

10. Characteristics

Table 8. Characteristics

At recommended operating conditions (see Table 7); unless otherwise specified.

| Symbol | Parameter | Conditions | Min | Typ | Max | Unit |
|-----------------|-----------------------------------|--|-----|-----|-----|------|
| V _{OH} | HIGH-level output voltage | I _{OH} = -6 mA; V _{DD} = 1.7 V | 1.2 | - | - | V |
| V _{OL} | LOW-level output voltage | I _{OL} = 6 mA; V _{DD} = 1.7 V | - | - | 0.5 | V |
| I _I | input current | all inputs; V _I = V _{DD} or GND; V _{DD} = 2.0 V | - | - | ±5 | μA |
| I _{DD} | supply current | static Standby mode; RESET = GND; I _O = 0 mA; V _{DD} = 2.0 V | - | - | 2 | mA |
| | | static Operating mode; RESET = V _{DD} ; I _O = 0 mA; V _{DD} = 2.0 V; V _I = V _{IH(AC)} or V _{IL(AC)} | - | - | 40 | mA |
| I _{DD} | dynamic operating current per MHz | clock only; RESET = V _{DD} ; V _I = V _{IH(AC)} or V _{IL(AC)} ; CK and CK switching at 50 % duty cycle; I _O = 0 mA; V _{DD} = 1.8 V | - | 16 | - | μA |
| | | per each data input, 1 : 1 mode; RESET = V _{DD} ; V _I = V _{IH(AC)} or V _{IL(AC)} ; CK and CK switching at 50 % duty cycle; one data input switching at half clock frequency, 50 % duty cycle; I _O = 0 mA; V _{DD} = 1.8 V | - | 11 | - | μA |
| | | per each data input, 1 : 2 mode; RESET = V _{DD} ; V _I = V _{IH(AC)} or V _{IL(AC)} ; CK and CK switching at 50 % duty cycle; one data input switching at half clock frequency, 50 % duty cycle; I _O = 0 mA; V _{DD} = 1.8 V | - | 19 | - | μA |
| C _i | input capacitance | data and CSR inputs; V _I = V _{ref} ± 250 mV; V _{DD} = 1.8 V | 2.5 | - | 3.5 | pF |
| | | CK and CK inputs; V _{ICR} = 0.9 V; V _{i(p-p)} = 600 mV; V _{DD} = 1.8 V | 2 | - | 3 | pF |
| | | RESET input; V _I = V _{DD} or GND; V _{DD} = 1.8 V | 3 | - | 4 | pF |
| Z _o | output impedance | instantaneous | [1] | 7 | - | Ω |
| | | steady-state | - | 53 | - | Ω |

[1] Instantaneous is defined as within < 2 ns following the output data transition edge.

Table 9. Timing requirements

At recommended operating conditions (see [Table 7](#)), unless otherwise specified. See [Section 11.1](#).

| Symbol | Parameter | Conditions | Min | Typ | Max | Unit |
|--------------------|-----------------------------------|---|--------|-----|-----|------|
| f _{clock} | clock frequency | | - | - | 550 | MHz |
| t _W | pulse width | CK, \overline{CK} HIGH or LOW | 1 | - | - | ns |
| t _{ACT} | differential inputs active time | | [1][2] | - | 10 | ns |
| t _{INACT} | differential inputs inactive time | | [1][3] | - | 15 | ns |
| t _{su} | setup time | \overline{DCS} before CK \uparrow , \overline{CK} \downarrow , \overline{CSR} HIGH; \overline{CSR} before CK \uparrow , \overline{CK} \downarrow , \overline{DCS} HIGH | 0.6 | - | - | ns |
| | | \overline{DCS} before CK \uparrow , \overline{CK} \downarrow , \overline{CSR} LOW | 0.5 | - | - | ns |
| | | DODT, DCKE and data (Dn) before CK \uparrow , CK \downarrow | 0.5 | - | - | ns |
| | | PAR_IN before CK \uparrow , \overline{CK} \downarrow | 0.5 | - | - | ns |
| t _h | hold time | \overline{DCS} , DODT, DCKE and data (Dn) after CK \uparrow , \overline{CK} \downarrow | 0.4 | - | - | ns |
| | | PAR_IN after CK \uparrow , \overline{CK} \downarrow | 0.4 | - | - | ns |

[1] This parameter is not necessarily production tested.

[2] VREF must be held at a valid input voltage level and data inputs must be held LOW for a minimum time of t_{ACT(max)} after \overline{RESET} is taken HIGH.

[3] VREF, data and clock inputs must be held at valid levels (not floating) a minimum time of t_{INACT(max)} after \overline{RESET} is taken LOW.

Table 10. Switching characteristics

At recommended operating conditions (see [Table 7](#)), unless otherwise specified. See [Section 11.1](#).

| Symbol | Parameter | Conditions | Min | Typ | Max | Unit |
|--------------------|---|--|--------|-----|-----|--------|
| f _{max} | maximum input clock frequency | | 550 | - | - | MHz |
| t _{PDM} | peak propagation delay | single bit switching; from CK \uparrow and \overline{CK} \downarrow to Qn | [1] | 1.0 | - | 1.4 ns |
| t _{PD} | propagation delay | from CK \uparrow and \overline{CK} \downarrow to PPO | 0.5 | - | 1.7 | ns |
| t _{LH} | LOW-to-HIGH delay | from CK \uparrow and \overline{CK} \downarrow to \overline{QERR} | 1.2 | - | 3 | ns |
| t _{HL} | HIGH-to-LOW delay | from CK \uparrow and \overline{CK} \downarrow to \overline{QERR} | 1 | - | 2.4 | ns |
| t _{PDMSS} | simultaneous switching peak propagation delay | from CK \uparrow and \overline{CK} \downarrow to Qn | [1][2] | - | - | 1.5 ns |
| t _{PHL} | HIGH-to-LOW propagation delay | from \overline{RESET} \downarrow to Qn \downarrow | - | - | 3 | ns |
| | | from \overline{RESET} \downarrow to PPO \downarrow | - | - | 3 | ns |
| t _{PLH} | LOW-to-HIGH propagation delay | from \overline{RESET} \downarrow to \overline{QERR} \uparrow | - | - | 3 | ns |

[1] Includes 350 ps of test load transmission line delay.

[2] This parameter is not necessarily production tested.

Table 11. Data output edge rates

At recommended operating conditions (see [Table 7](#)), unless otherwise specified. See [Section 11.2](#).

| Symbol | Parameter | Conditions | Min | Typ | Max | Unit |
|--------------------|---|-----------------------------------|-----|-----|-----|------|
| dV/dt _r | rising edge slew rate | from 20 % to 80 % | 1 | - | 4 | V/ns |
| dV/dt _f | falling edge slew rate | from 80 % to 20 % | 1 | - | 4 | V/ns |
| dV/dt _Δ | absolute difference between dV/dt _r and dV/dt _f | from 20 % or 80 % to 80 % or 20 % | - | - | 1 | V/ns |

10.1 Timing diagrams

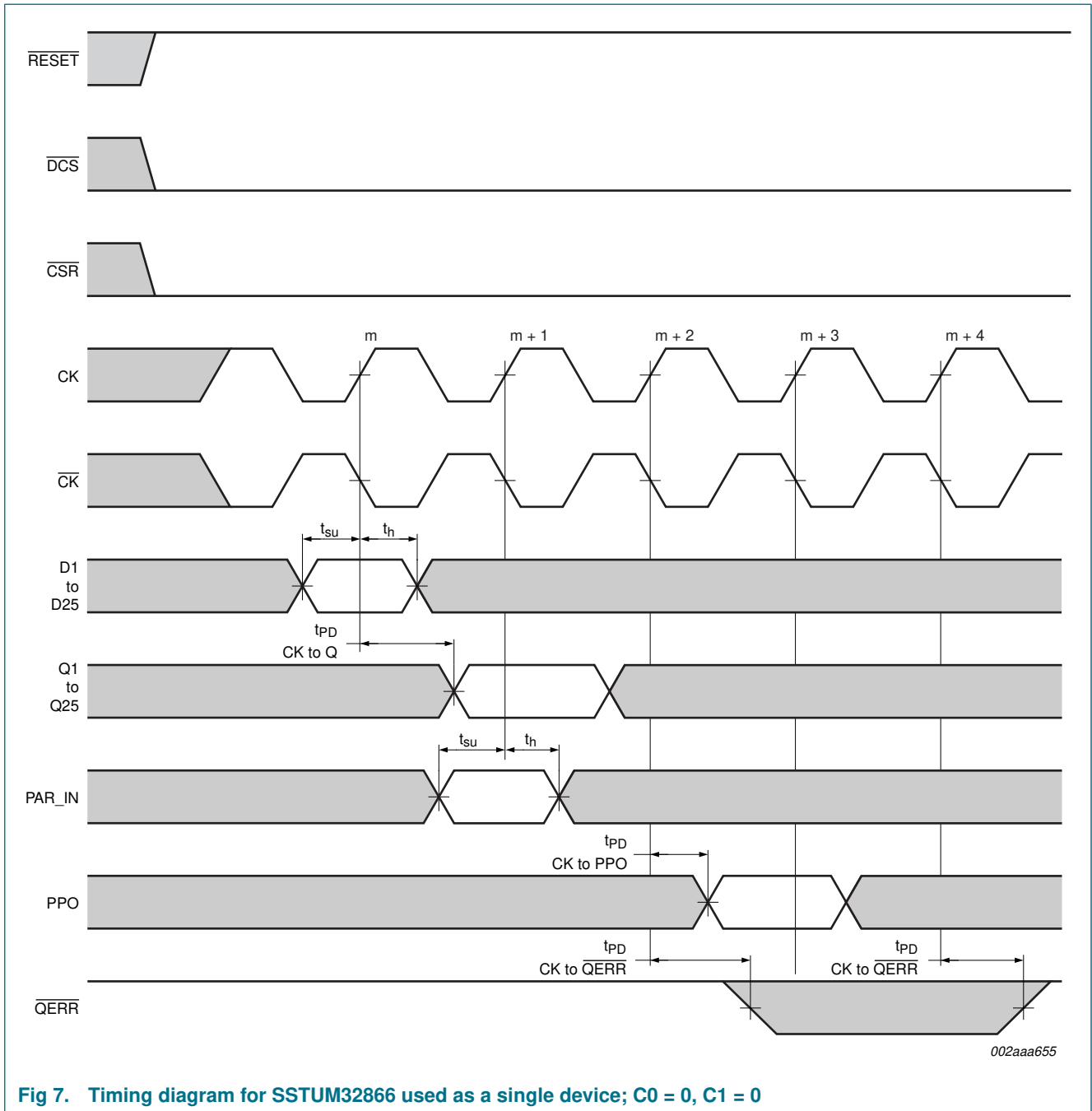
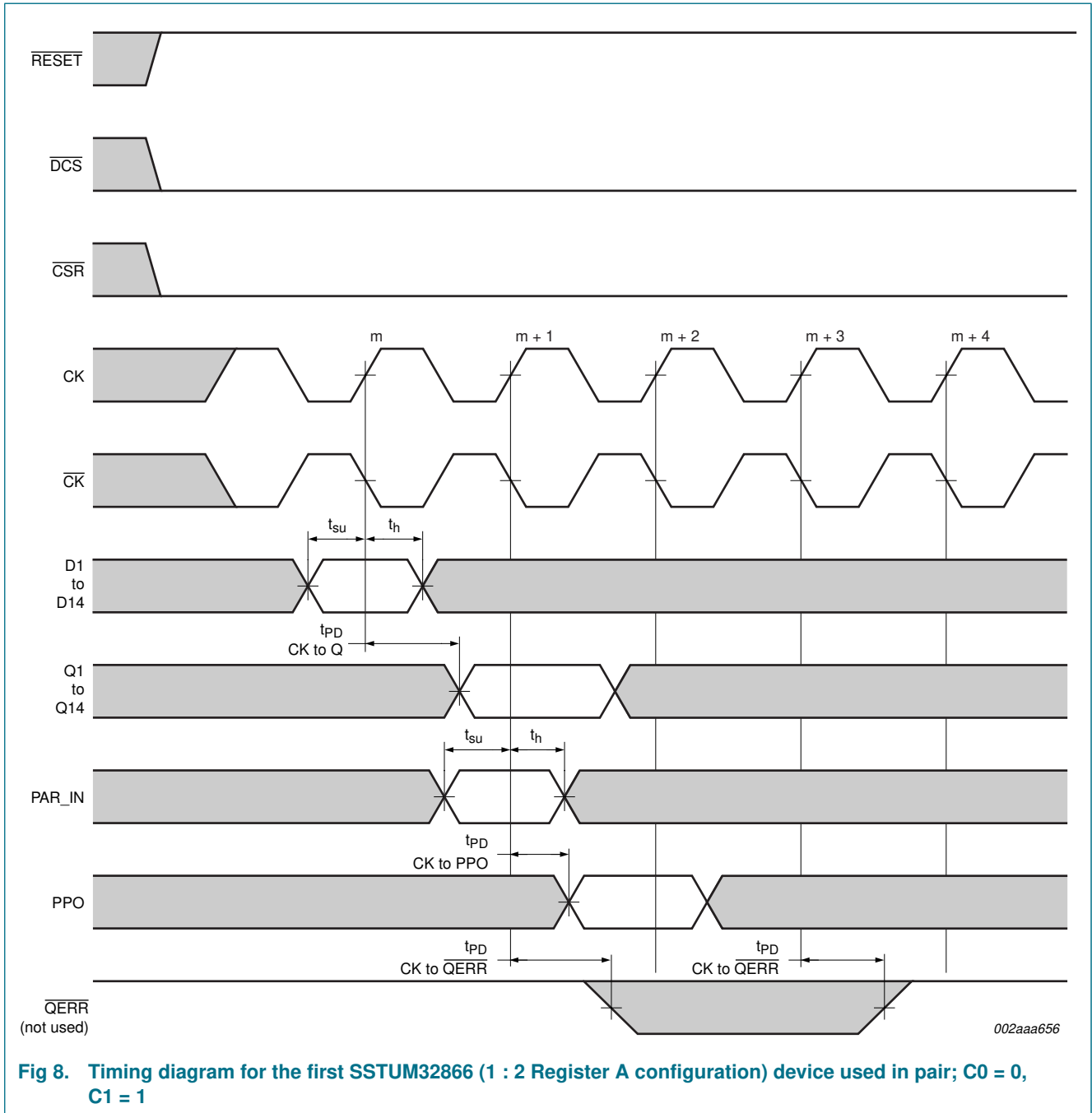
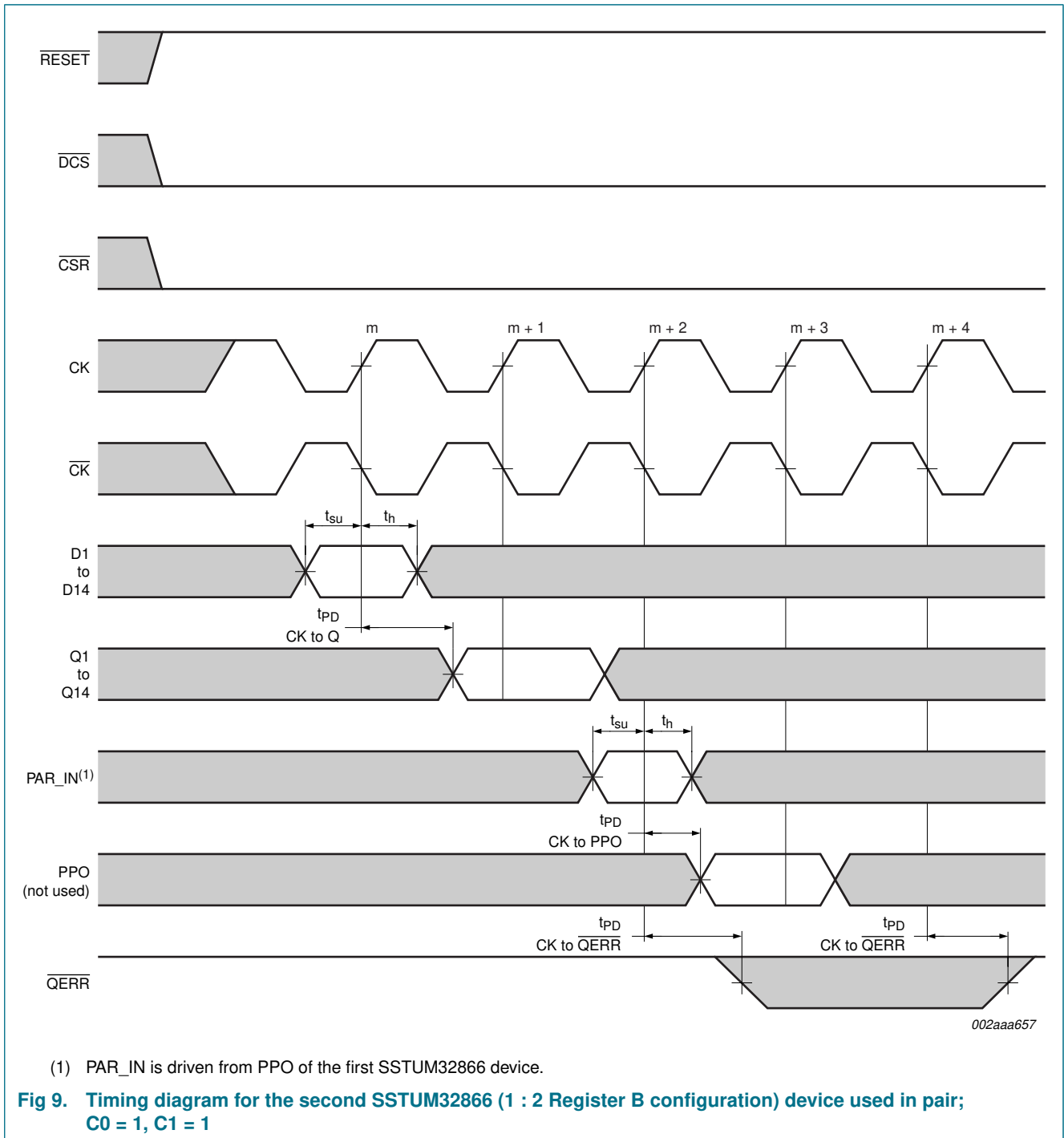

Fig 7. Timing diagram for SSTUM32866 used as a single device; C0 = 0, C1 = 0





11. Test information

11.1 Parameter measurement information for data output load circuit

$V_{DD} = 1.8 \text{ V} \pm 0.1 \text{ V}$.

All input pulses are supplied by generators having the following characteristics:
 $PRR \leq 10 \text{ MHz}$; $Z_o = 50 \Omega$; input slew rate = $1 \text{ V/ns} \pm 20 \%$, unless otherwise specified.

The outputs are measured one at a time with one transition per measurement.

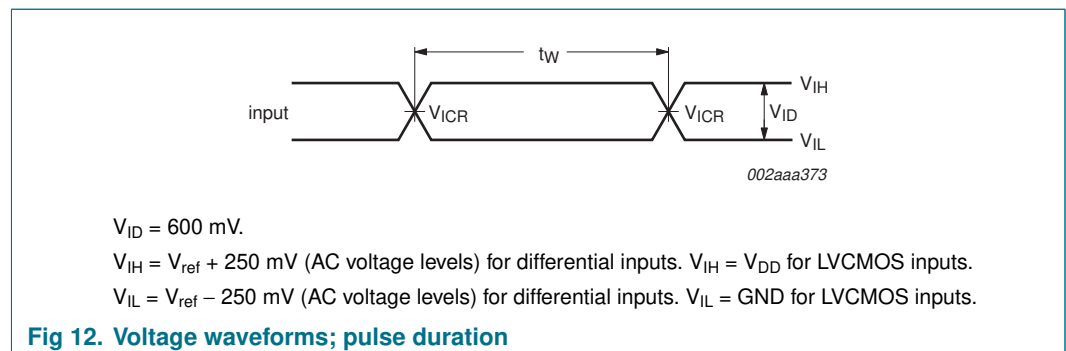
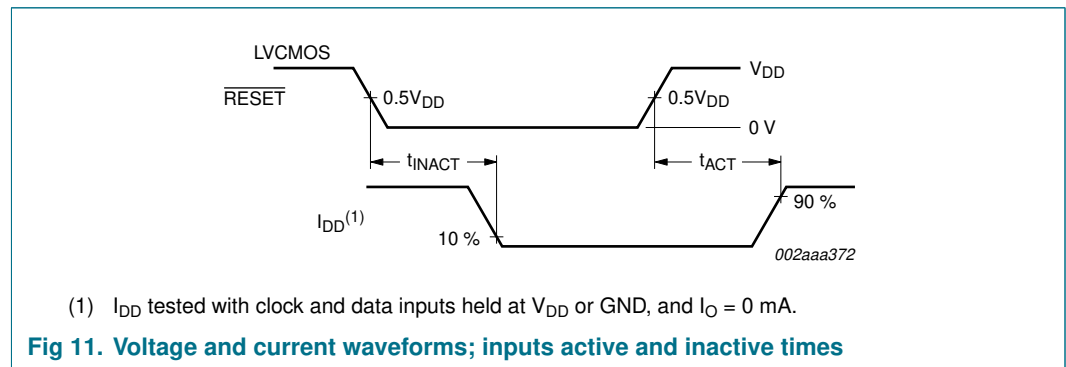
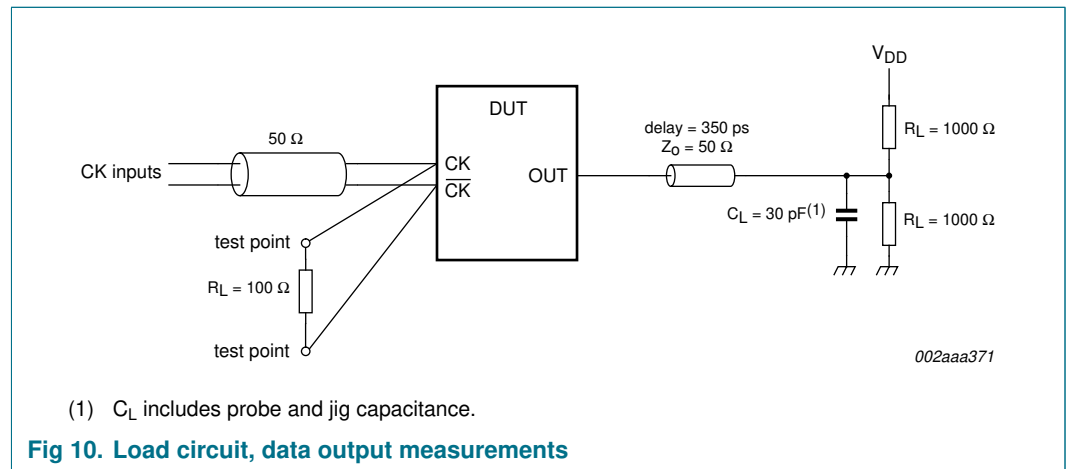

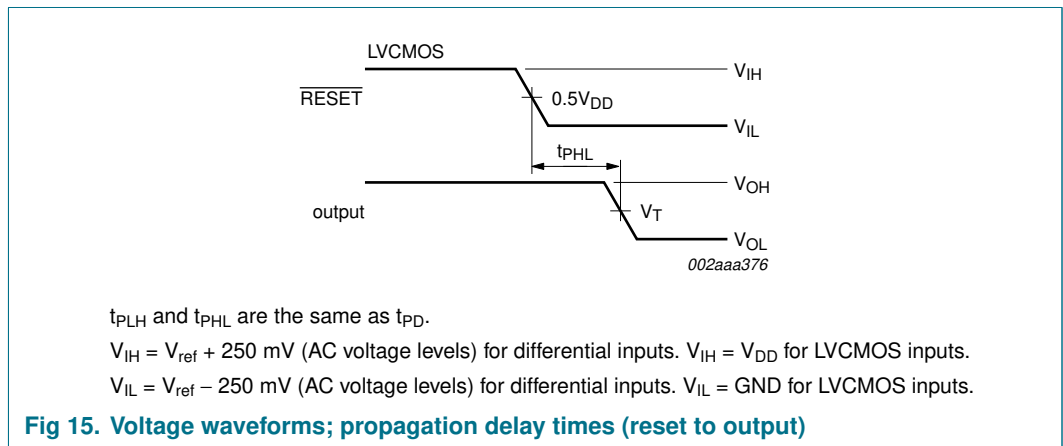
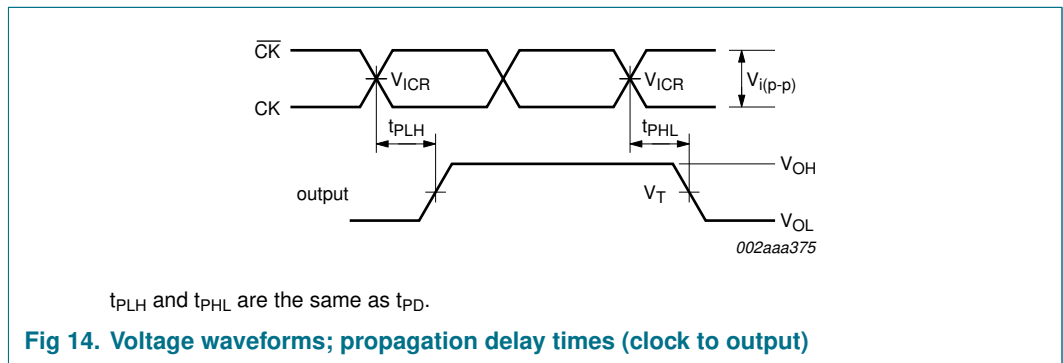
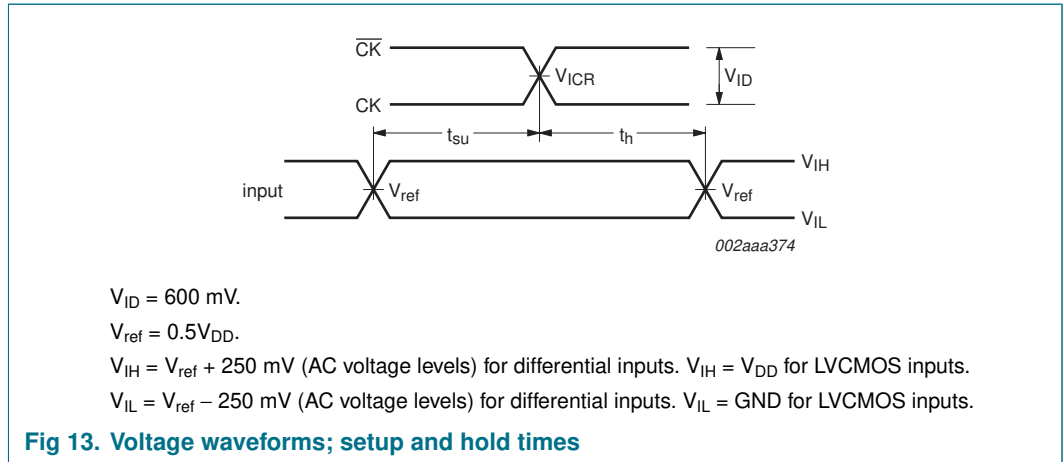

11.2 Data output slew rate measurement information

$V_{DD} = 1.8 V \pm 0.1 V$.

All input pulses are supplied by generators having the following characteristics: $PRR \leq 10 \text{ MHz}$; $Z_o = 50 \Omega$; input slew rate = $1 \text{ V/ns} \pm 20 \%$, unless otherwise specified.

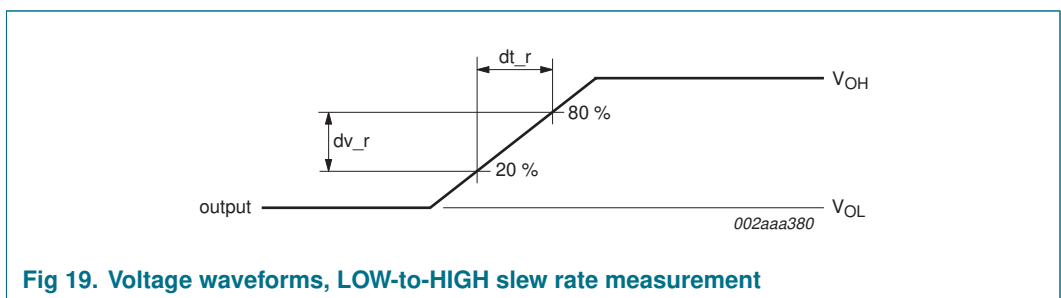
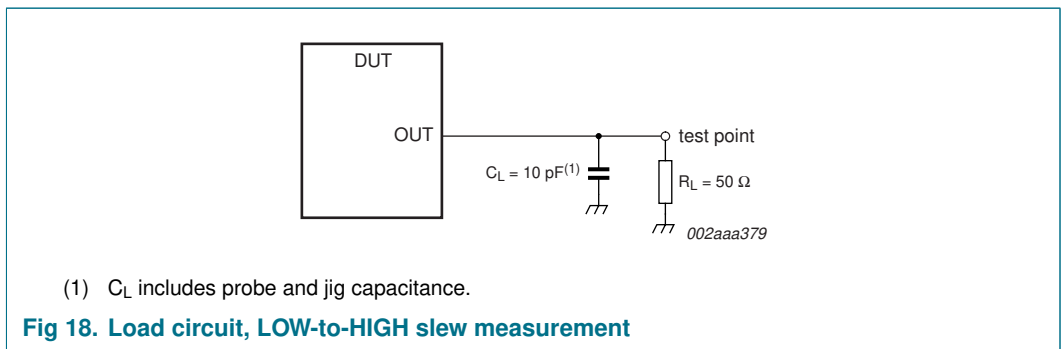
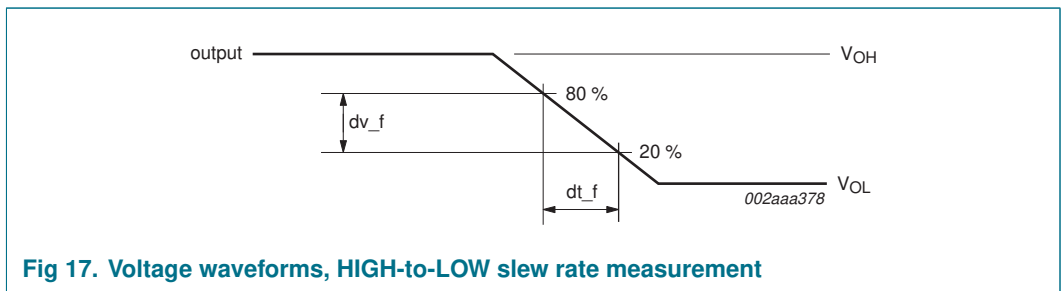
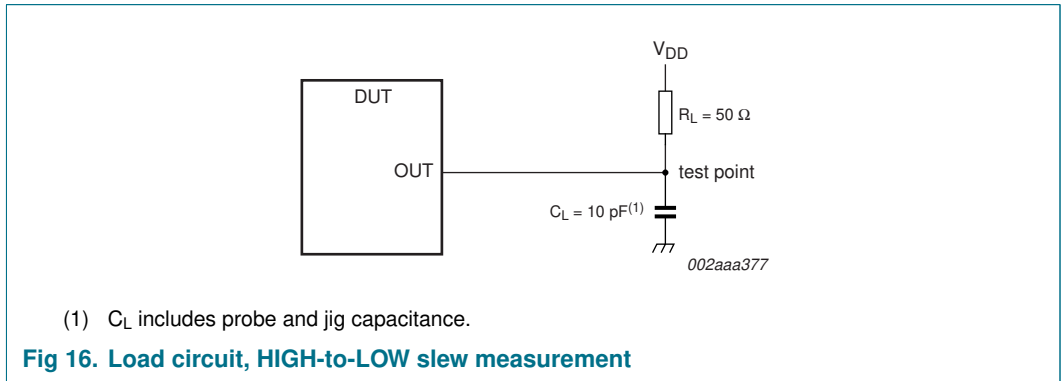

11.3 Error output load circuit and voltage measurement information

$V_{DD} = 1.8\text{ V} \pm 0.1\text{ V}$.

All input pulses are supplied by generators having the following characteristics: $PRR \leq 10\text{ MHz}$; $Z_o = 50\ \Omega$; input slew rate = $1\text{ V/ns} \pm 20\%$, unless otherwise specified.

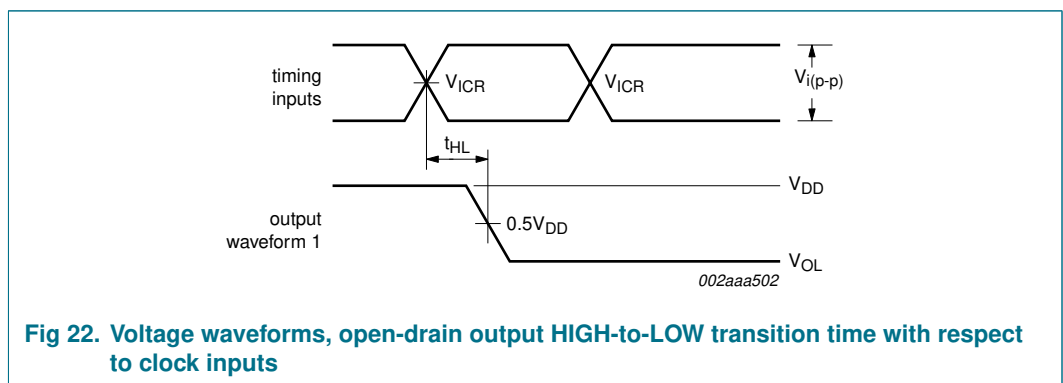
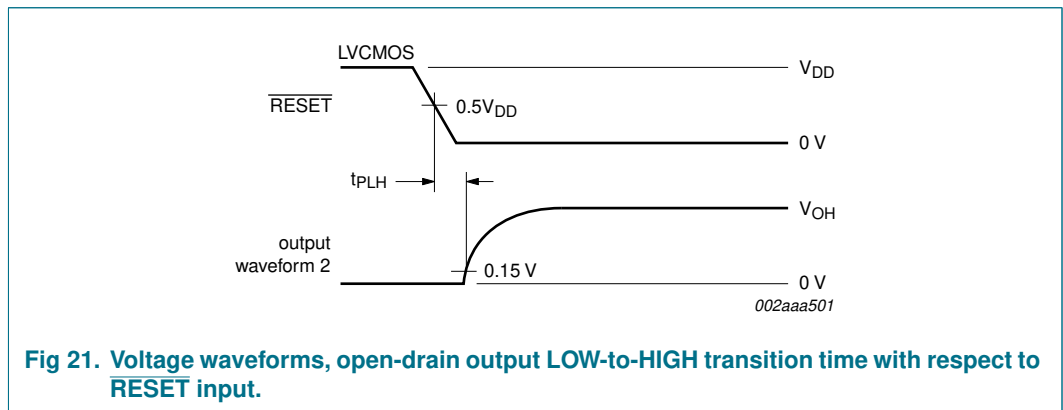
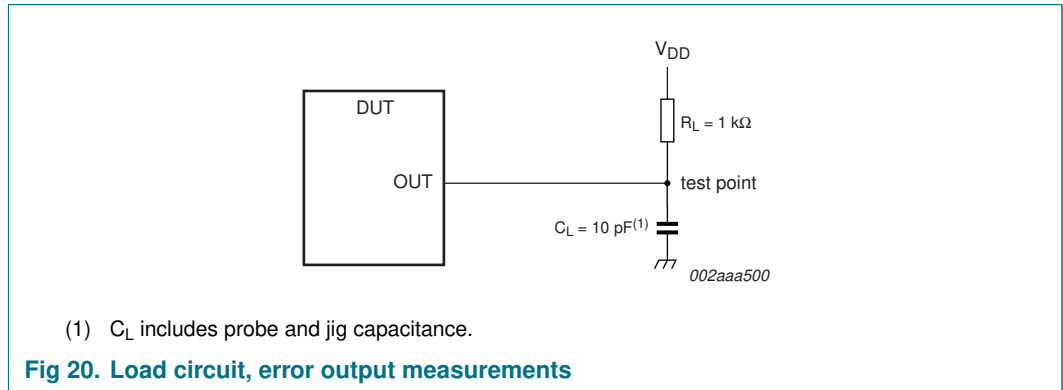

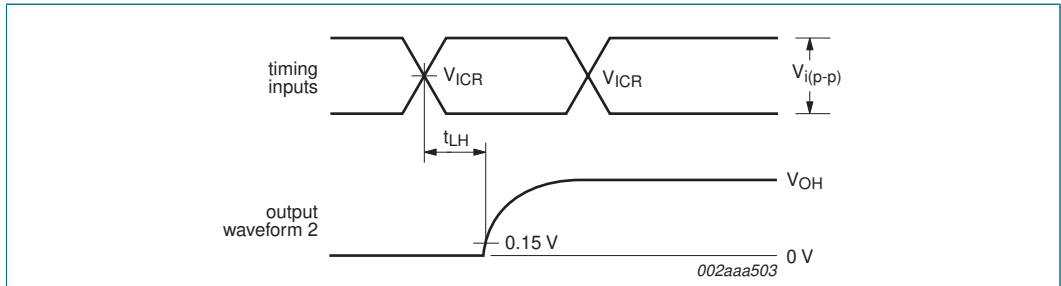

Fig 23. Voltage waveforms, open-drain output LOW-to-HIGH transition time with respect to clock inputs

11.4 Partial parity out load circuit and voltage measurement information

$V_{DD} = 1.8 V \pm 0.1 V.$

All input pulses are supplied by generators having the following characteristics:
 PRR ≤ 10 MHz; $Z_o = 50 \Omega$; input slew rate = $1 V/ns \pm 20 \%$, unless otherwise specified.

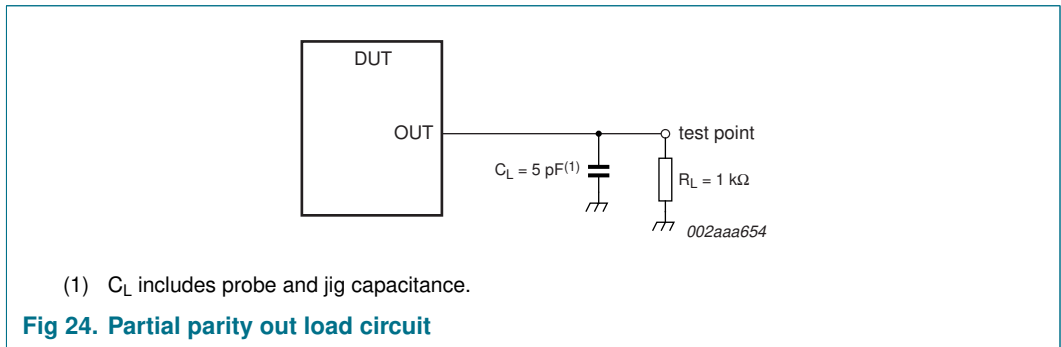

Fig 24. Partial parity out load circuit

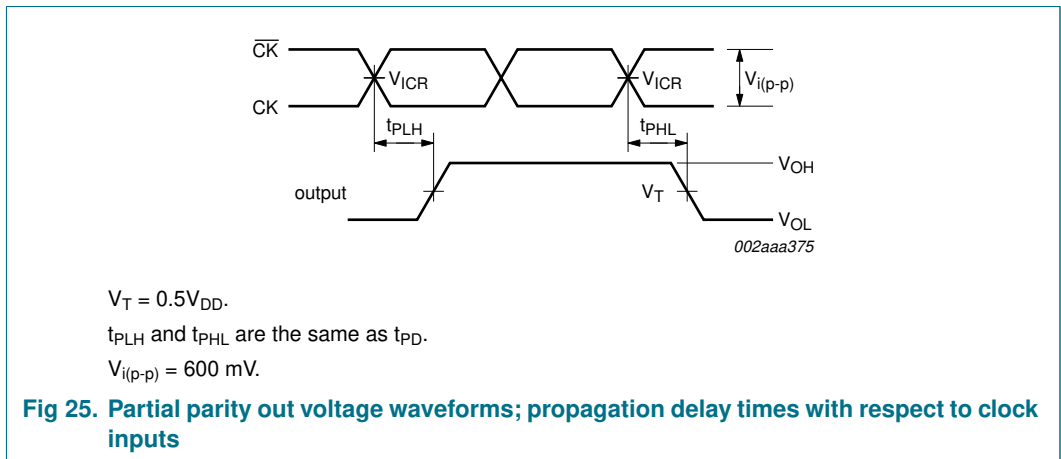
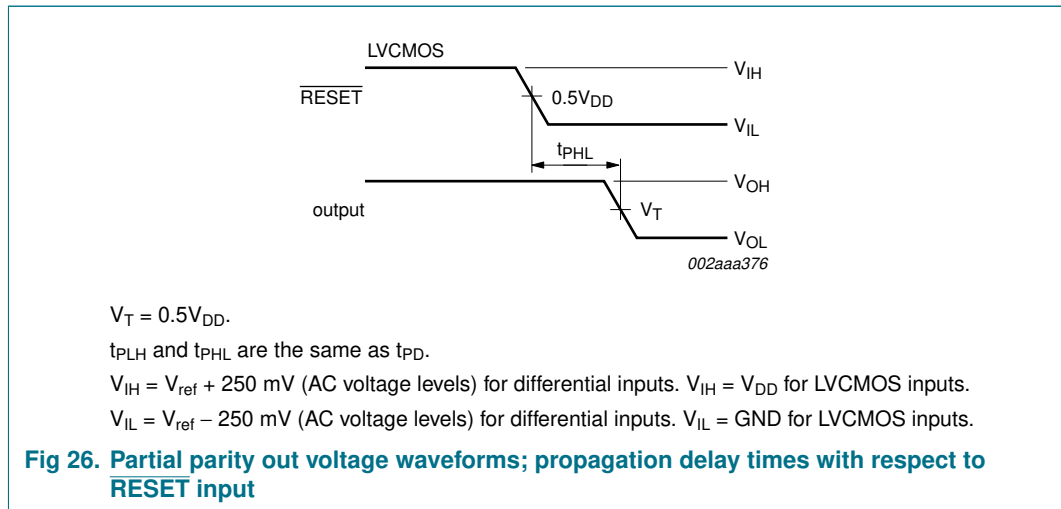

Fig 25. Partial parity out voltage waveforms; propagation delay times with respect to clock inputs



12. Package outline

LFBGA96: plastic low profile fine-pitch ball grid array package; 96 balls; body 13.5 x 5.5 x 1.05 mm SOT536-1

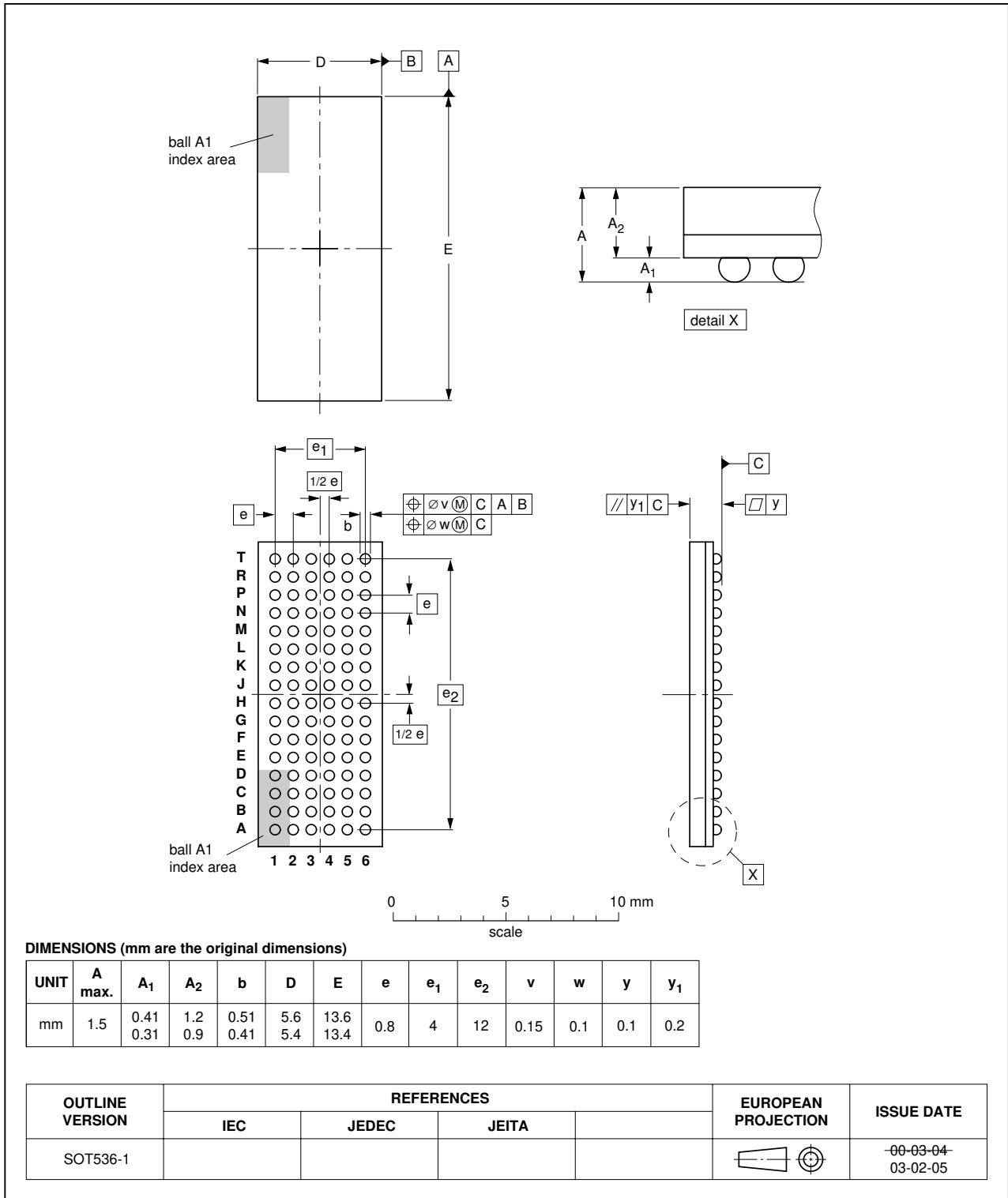

Fig 27. Package outline SOT536-1 (LFBGA96)

13. Soldering

This text provides a very brief insight into a complex technology. A more in-depth account of soldering ICs can be found in Application Note *AN10365 "Surface mount reflow soldering description"*.

13.1 Introduction to soldering

Soldering is one of the most common methods through which packages are attached to Printed Circuit Boards (PCBs), to form electrical circuits. The soldered joint provides both the mechanical and the electrical connection. There is no single soldering method that is ideal for all IC packages. Wave soldering is often preferred when through-hole and Surface Mount Devices (SMDs) are mixed on one printed wiring board; however, it is not suitable for fine pitch SMDs. Reflow soldering is ideal for the small pitches and high densities that come with increased miniaturization.

13.2 Wave and reflow soldering

Wave soldering is a joining technology in which the joints are made by solder coming from a standing wave of liquid solder. The wave soldering process is suitable for the following:

- Through-hole components
- Leaded or leadless SMDs, which are glued to the surface of the printed circuit board

Not all SMDs can be wave soldered. Packages with solder balls, and some leadless packages which have solder lands underneath the body, cannot be wave soldered. Also, leaded SMDs with leads having a pitch smaller than ~0.6 mm cannot be wave soldered, due to an increased probability of bridging.

The reflow soldering process involves applying solder paste to a board, followed by component placement and exposure to a temperature profile. Leaded packages, packages with solder balls, and leadless packages are all reflow solderable.

Key characteristics in both wave and reflow soldering are:

- Board specifications, including the board finish, solder masks and vias
- Package footprints, including solder thieves and orientation
- The moisture sensitivity level of the packages
- Package placement
- Inspection and repair
- Lead-free soldering versus PbSn soldering

13.3 Wave soldering

Key characteristics in wave soldering are:

- Process issues, such as application of adhesive and flux, clinching of leads, board transport, the solder wave parameters, and the time during which components are exposed to the wave
- Solder bath specifications, including temperature and impurities

13.4 Reflow soldering

Key characteristics in reflow soldering are:

- Lead-free versus SnPb soldering; note that a lead-free reflow process usually leads to higher minimum peak temperatures (see [Figure 28](#)) than a PbSn process, thus reducing the process window
- Solder paste printing issues including smearing, release, and adjusting the process window for a mix of large and small components on one board
- Reflow temperature profile; this profile includes preheat, reflow (in which the board is heated to the peak temperature) and cooling down. It is imperative that the peak temperature is high enough for the solder to make reliable solder joints (a solder paste characteristic). In addition, the peak temperature must be low enough that the packages and/or boards are not damaged. The peak temperature of the package depends on package thickness and volume and is classified in accordance with [Table 12](#) and [13](#)

Table 12. SnPb eutectic process (from J-STD-020C)

| Package thickness (mm) | Package reflow temperature (°C) | |
|------------------------|---------------------------------|-------|
| | Volume (mm ³) | |
| | < 350 | ≥ 350 |
| < 2.5 | 235 | 220 |
| ≥ 2.5 | 220 | 220 |

Table 13. Lead-free process (from J-STD-020C)

| Package thickness (mm) | Package reflow temperature (°C) | | |
|------------------------|---------------------------------|-------------|--------|
| | Volume (mm ³) | | |
| | < 350 | 350 to 2000 | > 2000 |
| < 1.6 | 260 | 260 | 260 |
| 1.6 to 2.5 | 260 | 250 | 245 |
| > 2.5 | 250 | 245 | 245 |

Moisture sensitivity precautions, as indicated on the packing, must be respected at all times.

Studies have shown that small packages reach higher temperatures during reflow soldering, see [Figure 28](#).