



Chipsmall Limited consists of a professional team with an average of over 10 year of expertise in the distribution of electronic components. Based in Hongkong, we have already established firm and mutual-benefit business relationships with customers from,Europe,America and south Asia,supplying obsolete and hard-to-find components to meet their specific needs.

With the principle of “Quality Parts,Customers Priority,Honest Operation,and Considerate Service”,our business mainly focus on the distribution of electronic components. Line cards we deal with include Microchip,ALPS,ROHM,Xilinx,Pulse,ON,Everlight and Freescale. Main products comprise IC,Modules,Potentiometer,IC Socket,Relay,Connector.Our parts cover such applications as commercial,industrial, and automotives areas.

We are looking forward to setting up business relationship with you and hope to provide you with the best service and solution. Let us make a better world for our industry!



Contact us

Tel: +86-755-8981 8866 Fax: +86-755-8427 6832

Email & Skype: info@chipsmall.com Web: www.chipsmall.com

Address: A1208, Overseas Decoration Building, #122 Zhenhua RD., Futian, Shenzhen, China



SPECIFICATION

Model : Piezo Buzzer
 Spec No. : ST-0503-3

Customer Approval Status	SOBERTON File Publish Sign
Dsg'd : _____	Edition : <u>A</u>
Chk'd : _____	File clerk : _____
App'd : _____	
File Publish Sign	



211 North First Street Minneapolis, MN. 55401

Dsg'd _____



Chk'd _____



App'd _____



Web-site: www.soberton.com

Sales Kimberly Scheerer

MODEL NUMBER	CUSTOMER NUMBER	PRODUCT TYPE	REVERSION	DATE	PAGE
ST-0503-3		Buzzer	A	2014-11-21	1/5

A. SCOPE

This specification applies magnetic buzzer, **ST-0503-3**

B. SPECIFICATION

No.	Item	Unit	Specification	Condition
1	Oscillation Frequency	Hz	4000	Vo-p=1/2duty , square wave
2	Operating Voltage	Vo-p	2~ 4	
3	Rated Voltage	Vo-p	3	
4	Current Consumption	mA	MAX. 110	at Rated Voltage
5	Sound Pressure Level	dB	MIN. 75	at 10cm at Rated Voltage
6	Coil Resistance	Ω	12 \pm 3	
7	Operating Temperature	$^{\circ}$	-20 ~ +60	
8	Storage Temperature	$^{\circ}$	-30 ~ +80	
9	Dimension	mm	5.0 x 5.0 x H2.7	See appearance drawing
10	Weight (MAX)	gram	0.1	
11	Housing Material		LCP(Black)	
12	Leading Pin		Tin Plated Brass(Sn)	See appearance drawing
13	Environmental Protection Regulation		RoHS	

C. APPEARANCE DRAWING

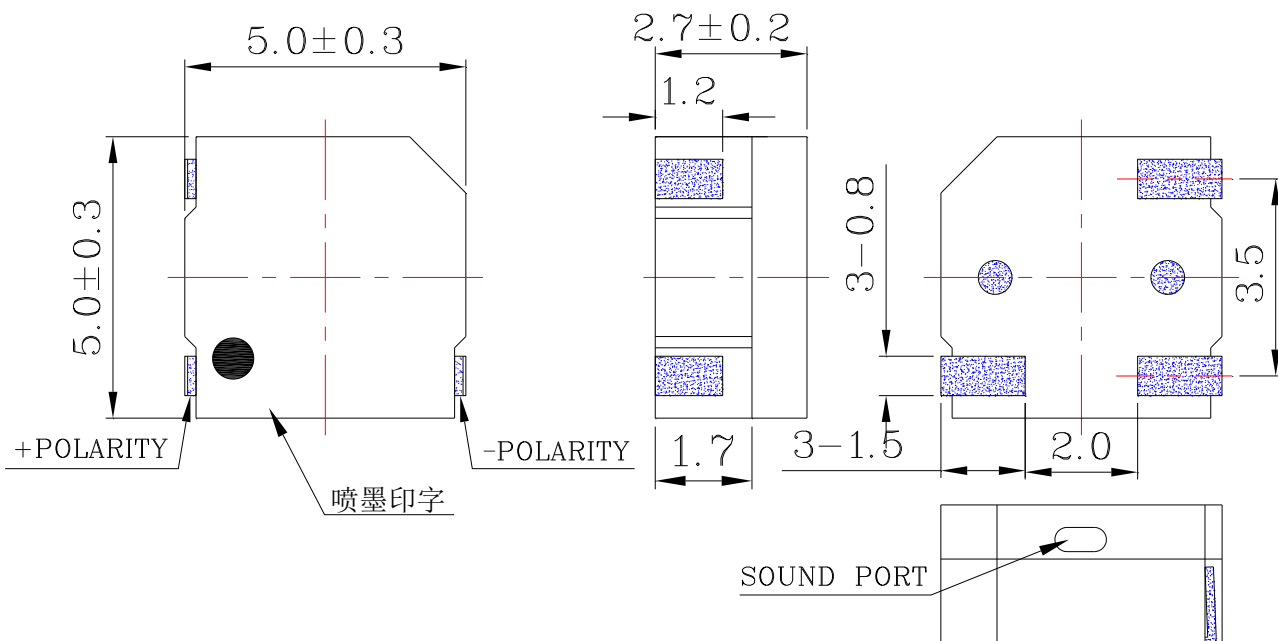

Tol : ± 0.3

Unit: mm

MODEL NUMBER	CUSTOMER NUMBER	PRODUCT TYPE	REVERSION	DATE	PAGE
ST-0503-3		Buzzer	A	2014-11-21	2/5

D. TESTING METHOD

Standard Measurement conditions

Temperature: $25 \pm 2^\circ\text{C}$ Humidity: 45-65%

Acoustic Characteristics:

The oscillation frequency, current consumption and sound pressure are measured by the measuring instruments shown below

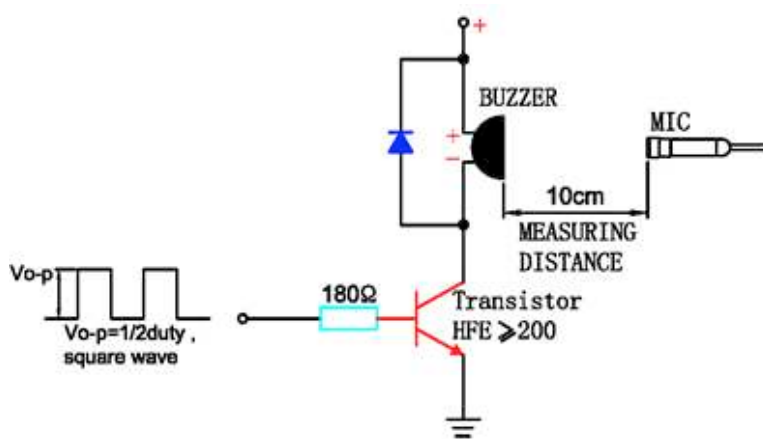

In the measuring test, buzzer is placed as follows:

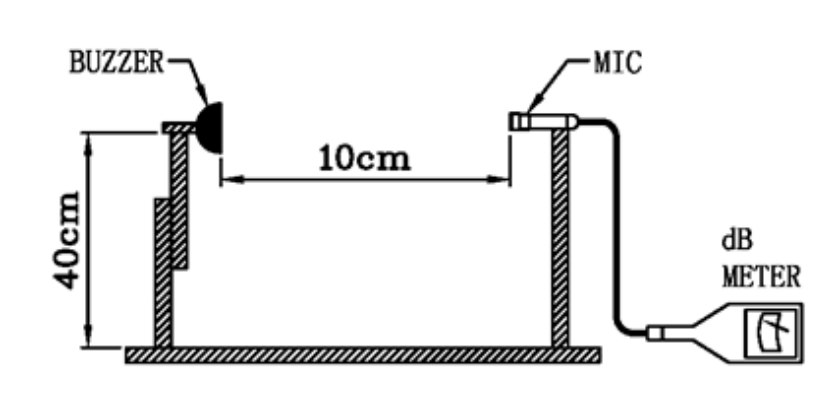

E. Typical Frequency Response Curve

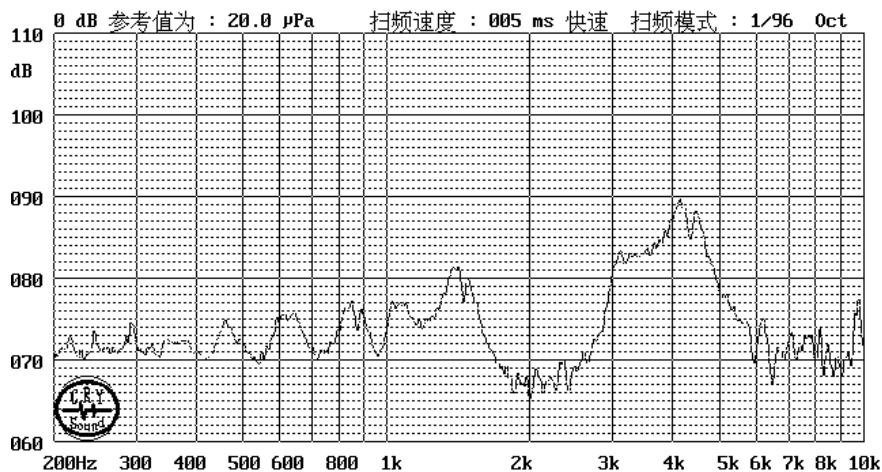

MODEL NUMBER	CUSTOMER NUMBER	PRODUCT TYPE	REVERSION	DATE	PAGE
ST-0503-3		Buzzer	A	2014-11-21	3/5

F. Recommend Driving Circuit

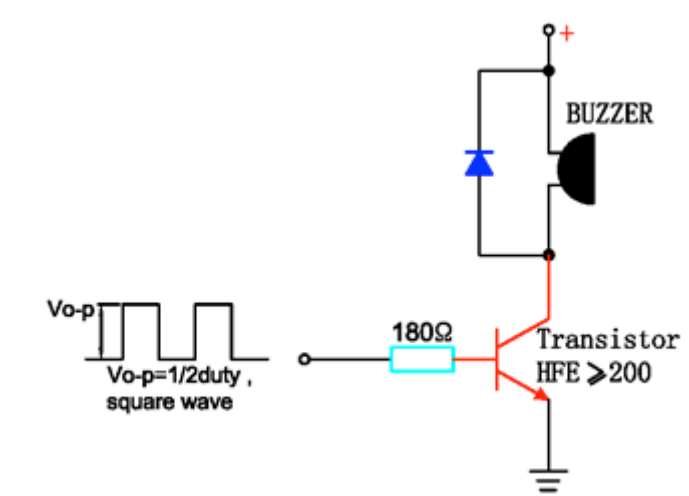

The base current I_b should high enough so that it saturates the collector current of the transistor with the CB load.

G. Soldering Condition

(1)Recommendable reflow soldering condition is as follows

(Reflow soldering is twice)

Note:It is requested that reflow soldering should be executed after heat of product goes down to normal.

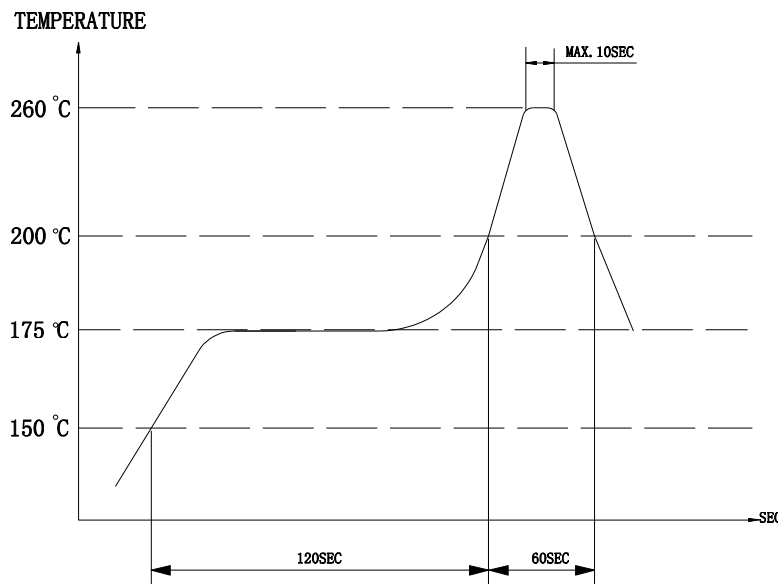

Heat resistant line

(Used when heat resistant reliability test is performed)

(2)Manual soldering

Manual soldering temperature 350°C within 5 sec.

MODEL NUMBER	CUSTOMER NUMBER	PRODUCT TYPE	REVERSION	DATE	PAGE
ST-0503-3		Buzzer	A	2014-11-21	4/5

H. RELIABILITY TEST

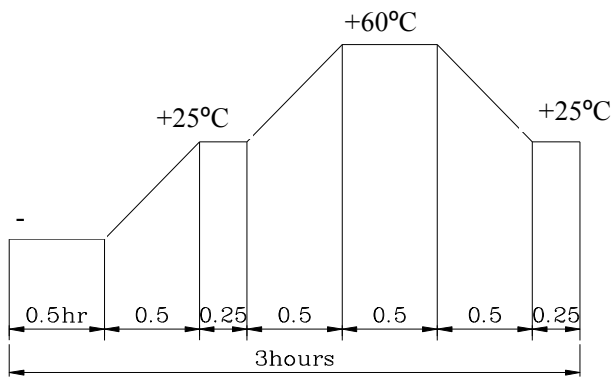
NO.	ITEM	TEST CONDITION AND REQUIREMENT
1	High Temperature Test (Storage)	After being placed in a chamber with 80±2°C for 96 hours and then being placed in normal condition for 2 hours. Allowable variation of SPL after test: ±10dB.
2	Low Temperature Test (Storage)	After being Placed in a chamber with -30±2°C for 96 hours and then being placed in normal condition for 2 hours. Allowable variation of SPL after test: ±10dB.
3	Humidity Test	After being Placed in a chamber with 90-95% R.H. at 40±2°C for 96 hours and then being placed in normal condition for 2 hours. Allowable variation of SPL after test: ±10dB.
4	Temperature Cycle Test	<p>The part shall be subjected to 5 cycles. One cycle shall be consist of:</p>  <p>The diagram shows a temperature cycle profile over 3 hours. It starts at a baseline temperature (indicated by a minus sign '-'). The cycle consists of the following segments: a 0.5 hr dwell at the baseline, a 0.5 hr ramp up to +25°C, a 0.25 hr dwell at +25°C, a 0.5 hr ramp up to +60°C, a 0.5 hr dwell at +60°C, a 0.5 hr ramp down to +25°C, a 0.5 hr dwell at +25°C, and a final 0.25 hr dwell at +25°C. The total duration of the cycle is 3 hours.</p> <p>Allowable variation of SPL after test: ±10dB.</p>
5	Drop Test	Drop on a hard wood board of 4cm thick, any directions ,6 times, at the height of 75cm . Allowable variation of SPL after test: ±10dB.
6	Vibration Test	After being applied vibration of amplitude of 1.5mm with 10 to 55 Hz band of vibration frequency to each of 3 perpendicular directions for 2 hours . Allowable variation of SPL after test: ±10dB.
7	Solderability Test	Lead terminals are immersed in rosin for 5 seconds and then immersed in solder bath of +300±5°C for 3±1 seconds . 90% min. lead terminals shall be wet with solder (Except the edge of terminals).
8	Terminal Strength Pulling Test	The force of 9.8N(1.0kg) is applied to each terminal in axial direction for 10 seconds. No visible damage and cutting off.

TEST CONDITION.

Standard Test Conditio : a) Temperature : +5 ~ +35°C b) Humidity : 45-85% c) Pressure : 860-1060mbar

Judgment Test Conditio : a) Temperature : +25 ± 2°C b) Humidity : 60-70% c) Pressure : 860-1060mbar

I. PACKING STANDARD

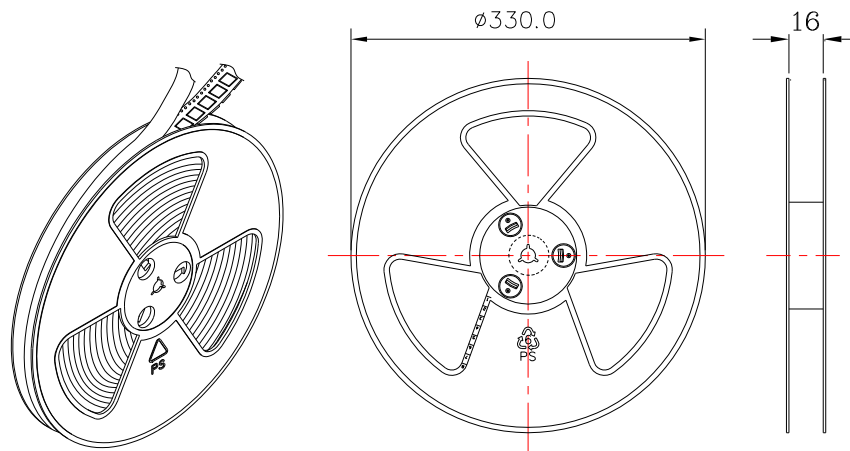

1 Reel : 2500PCS

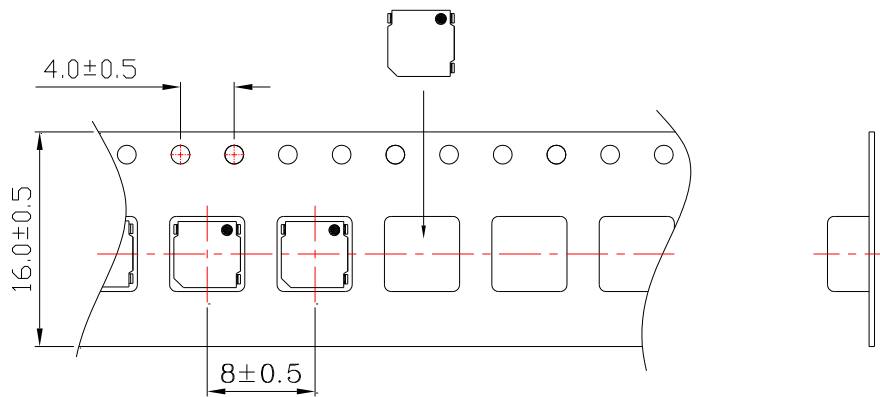

Carton Box
(10 Inner Box)

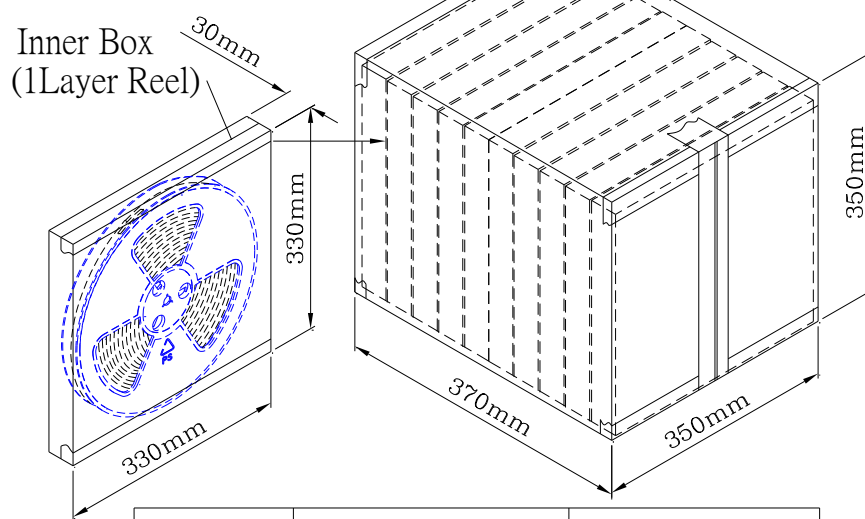

Inner Box	330mmx330mmx30mm	1x2500PCS=2500PCS
Carton Box	350mmx350mmx370mm	10x2500PCS=25,000PCS