



Chipsmall Limited consists of a professional team with an average of over 10 year of expertise in the distribution of electronic components. Based in Hongkong, we have already established firm and mutual-benefit business relationships with customers from,Europe,America and south Asia,supplying obsolete and hard-to-find components to meet their specific needs.

With the principle of “Quality Parts,Customers Priority,Honest Operation,and Considerate Service”,our business mainly focus on the distribution of electronic components. Line cards we deal with include Microchip,ALPS,ROHM,Xilinx,Pulse,ON,Everlight and Freescale. Main products comprise IC,Modules,Potentiometer,IC Socket,Relay,Connector.Our parts cover such applications as commercial,industrial, and automotives areas.

We are looking forward to setting up business relationship with you and hope to provide you with the best service and solution. Let us make a better world for our industry!



## Contact us

Tel: +86-755-8981 8866 Fax: +86-755-8427 6832

Email & Skype: info@chipsmall.com Web: www.chipsmall.com

Address: A1208, Overseas Decoration Building, #122 Zhenhua RD., Futian, Shenzhen, China



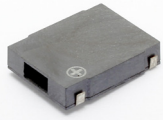

**MODEL:** ST-1411  
**PRODUCT:** Electro Magnetic Buzzer  
**EDITION:** A/2016

**THIS SPECIFICATION APPLIES TO THE ELECTROMAGNETIC BUZZER**

**SPECIFICATION**

Test condition: TEMP=+25±2 °C Related humidity=65±5% Air pressure:860-1060mbar

item	unit	specification	condition
rated voltage	Vo-p	3.0	
operating volt	Vo-p	2-4	
mean current	mA	80 Max	At rated voltage 3200Hz square wave, 1/2 duty
coil resistance	Ω	18±3	
sound output	dBA	87	At 10cm(A-weight free air), at rated voltage 3200Hz, square wave, 1/2duty
rated frequency	Hz	3200	
operating temp	°C	-30 ~ +80	
storage temp	°C	-40 ~ +85	
dimension	mm	L14×W11×H3.0	See attached drawing
weight	gram	1.0	
material		LCP(Black)	
terminal		SMD type (Plating Sn)	See attached drawing
environmental protection regulation		RoHS	

**ENVIRONMENT TEST**

item	test condition	evaluation standard
high temp. test	After being placed in a chamber at +80°C for 96 hours.	AAfter the test the part will meet specifications without any degradation in appearance and performance except SPL. after 4 hours at +25°C . The SPL will be in ±10dBA compared with initial one.
low temp. test	After being placed in a chamber at -40°C for 96 hours.	
thermal shock	The part will be subjected to 10 cycles. One cycle shall consist of:	

temp./humidity cycle	The part will be subjected to 10 cycles. One cycle shall be 24 hours and consist of:
----------------------	---

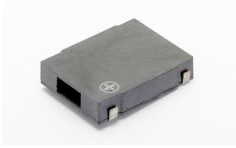

**MODEL:** ST-1411  
**PRODUCT:** Electro Magnetic Buzzer  
**EDITION:** A/2016

## RELIABILITY TEST

item	test conditions	evaluation standard
operating life test	CONTINUOUS LIFE TEST The part will be subjected to 72 hours of continuous operation at +60°C with 3.6V, 3200Hz applied	After the test the part will meet specifications without any degradation in appearance and performance except SPL, after 4 hours at +25°C. The SPL would be in ±10dBA compared with initial one.
	INTERMITTENT LIFE TEST A duty cycle of 1 minute on, 1 minutes off, a minimum of 10,000 times at room temp. (+25±10°C)with 3.6V,3200Hz applied.	

### TEST CONDITION

Standard Test Condition : a)Temperature: +5~+35 b)Humidity:45~85% c)Pressure: 860~1060mbar

## MECHANICAL CHARACTERISTICS

item	test condition	evaluation standard
solderability	Lead terminals are immersed in solder bath of +270±5°C for 3±1 second	90% min. lead terminals will be wet with solder No interference in operation.
soldering heat resistance	The product followed the reflow profile to test its reflow thermo-stability.	
terminal mechanical strength	Lead pads will be soldered on the pc board, and the force 9.8N(1.0Kg) will be applied behind the part for 10 seconds.	No damage and cutting off
vibration	The part will be subjected to a vibration cycle of 10Hz to 55Hz to 10Hz in a period of 1 minute. Total peak amplitude will be 1.52mm(9.3G). The vibration test will consist of 2 hours per axis in each three axes (X,Y, Z). Total 6 hours.	After the test the part will meet specifications without any damage in appearance and performance except SPL. SPL would be in ±10dBA compared with initial one.
drop test	The part only shall be dropped from a height of 75cm onto a 40mm thick wooden board 3 times in 3 axes (X,Y, Z). Total of 9 times.	

## RECOMMENDED TEMPERATURE PROFILE FOR REFLOW OVEN

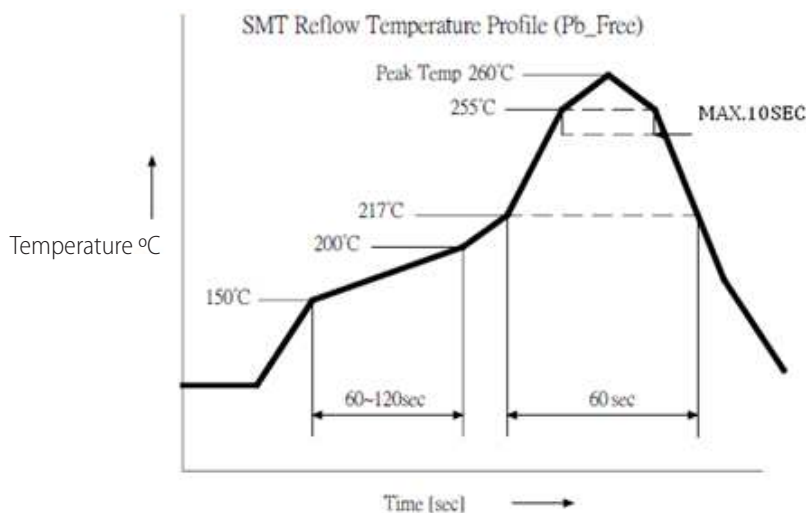

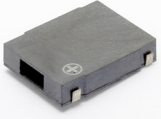

**MODEL:** ST-1411  
**PRODUCT:** Electro Magnetic Buzzer  
**EDITION:** A/2016

### MEASUREMENT TEST CIRCUIT

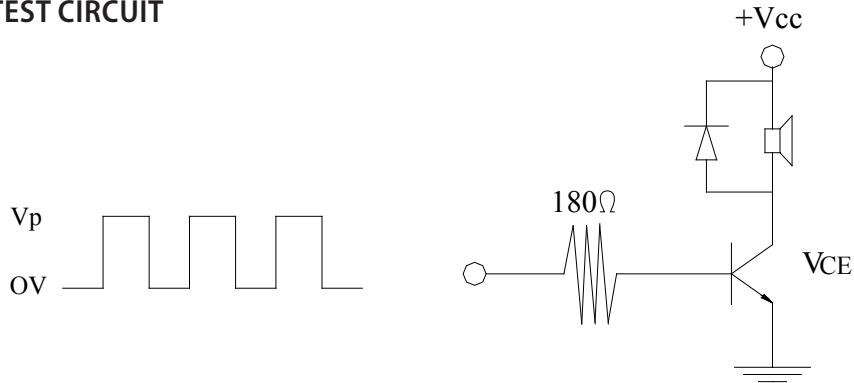

### INSPECTION FIXTURE

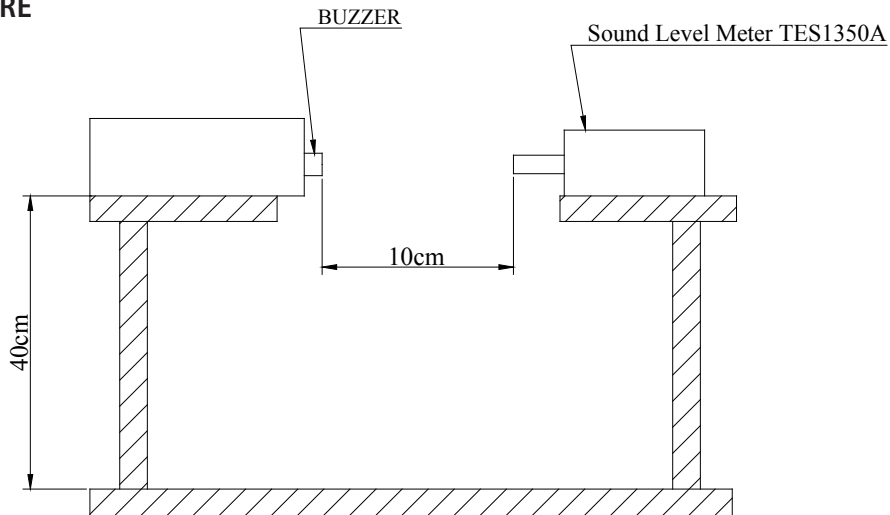

### DIMENSIONS

Tolerance:  $\pm 0.3$  (unit: mm)

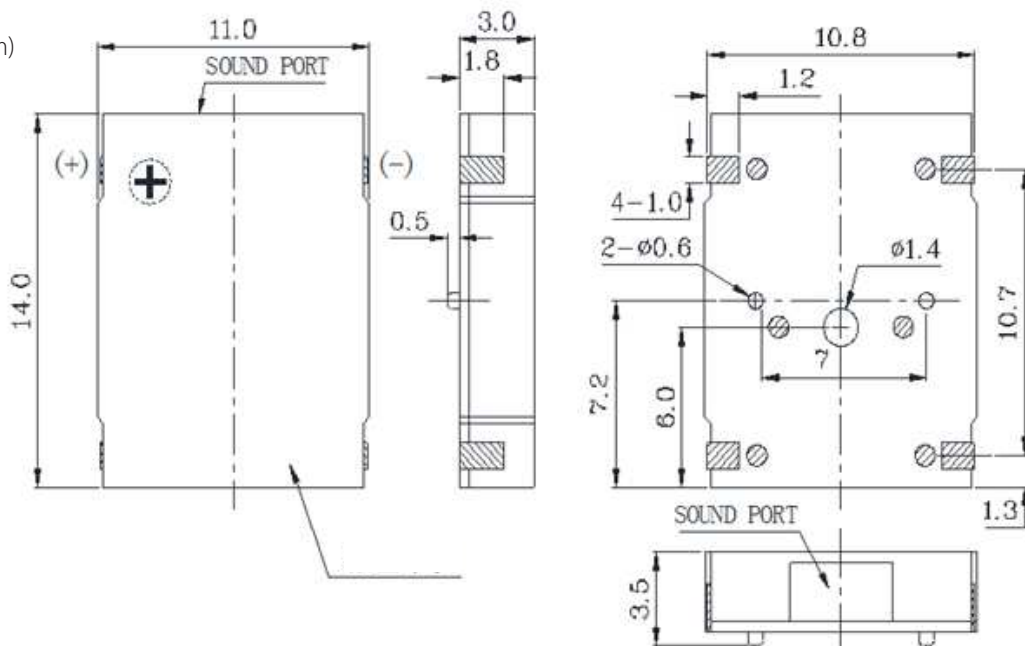

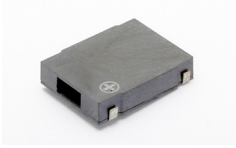

**MODEL:** ST-1411  
**PRODUCT:** Electro Magnetic Buzzer  
**EDITION:** A/2016

**PACKING**

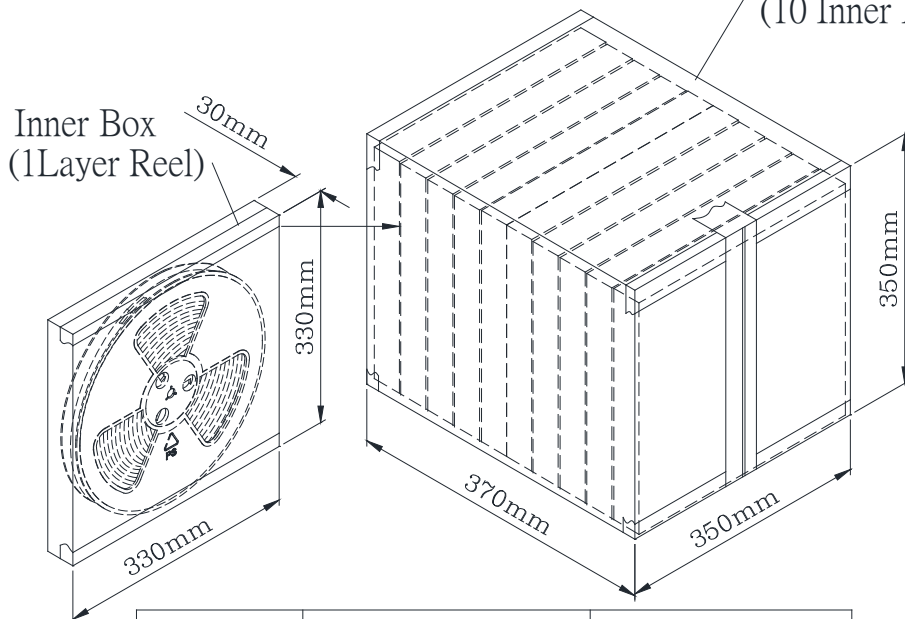
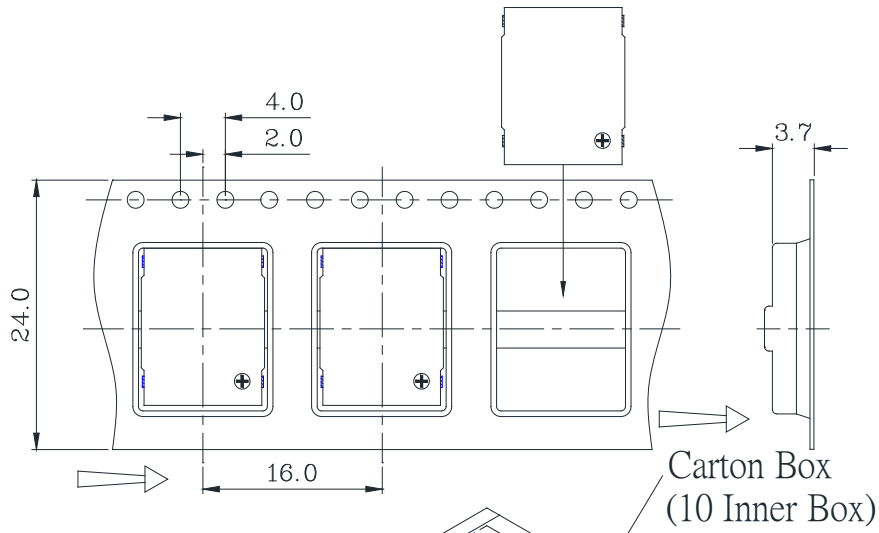
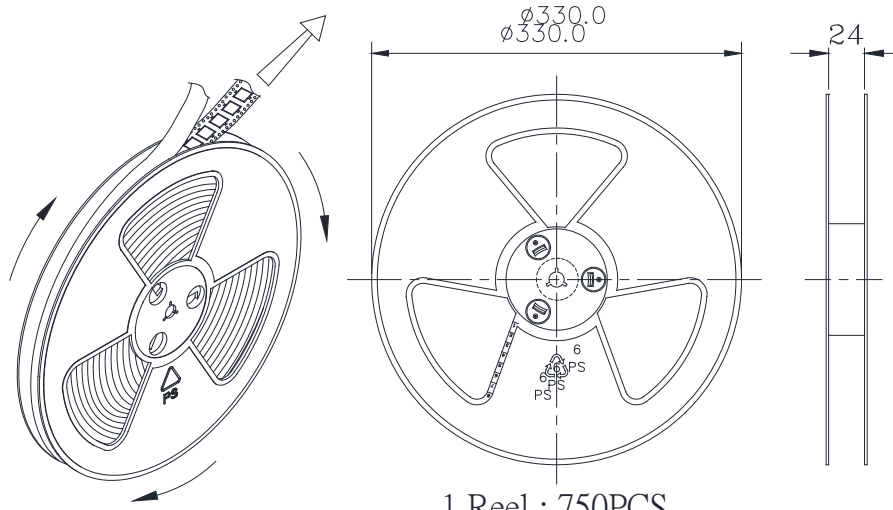

Inner Box	330mmx330mmx30mm	1x750PCS=750PCS
Carton Box	350mmx350mmx370mm	10x750PCS=7,500PCS