



Chipsmall Limited consists of a professional team with an average of over 10 year of expertise in the distribution of electronic components. Based in Hongkong, we have already established firm and mutual-benefit business relationships with customers from,Europe,America and south Asia,supplying obsolete and hard-to-find components to meet their specific needs.

With the principle of “Quality Parts,Customers Priority,Honest Operation,and Considerate Service”,our business mainly focus on the distribution of electronic components. Line cards we deal with include Microchip,ALPS,ROHM,Xilinx,Pulse,ON,Everlight and Freescale. Main products comprise IC,Modules,Potentiometer,IC Socket,Relay,Connector.Our parts cover such applications as commercial,industrial, and automotives areas.

We are looking forward to setting up business relationship with you and hope to provide you with the best service and solution. Let us make a better world for our industry!



Contact us

Tel: +86-755-8981 8866 Fax: +86-755-8427 6832

Email & Skype: info@chipsmall.com Web: www.chipsmall.com

Address: A1208, Overseas Decoration Building, #122 Zhenhua RD., Futian, Shenzhen, China



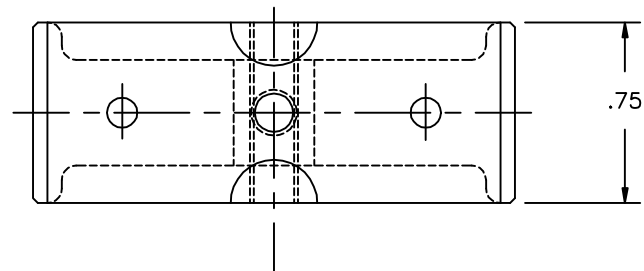
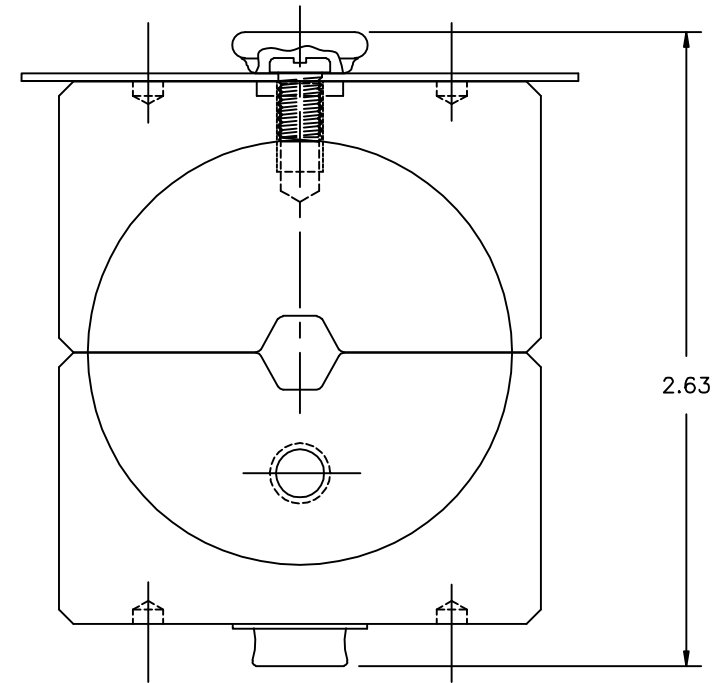
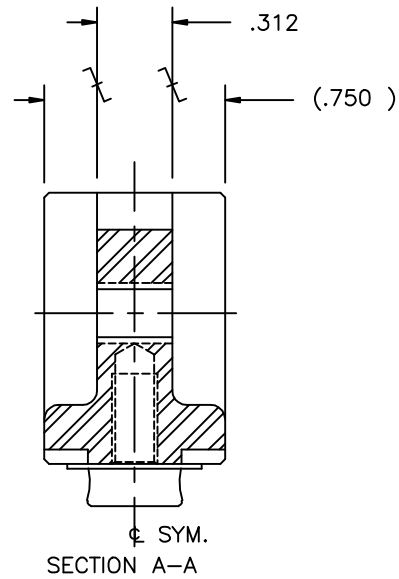
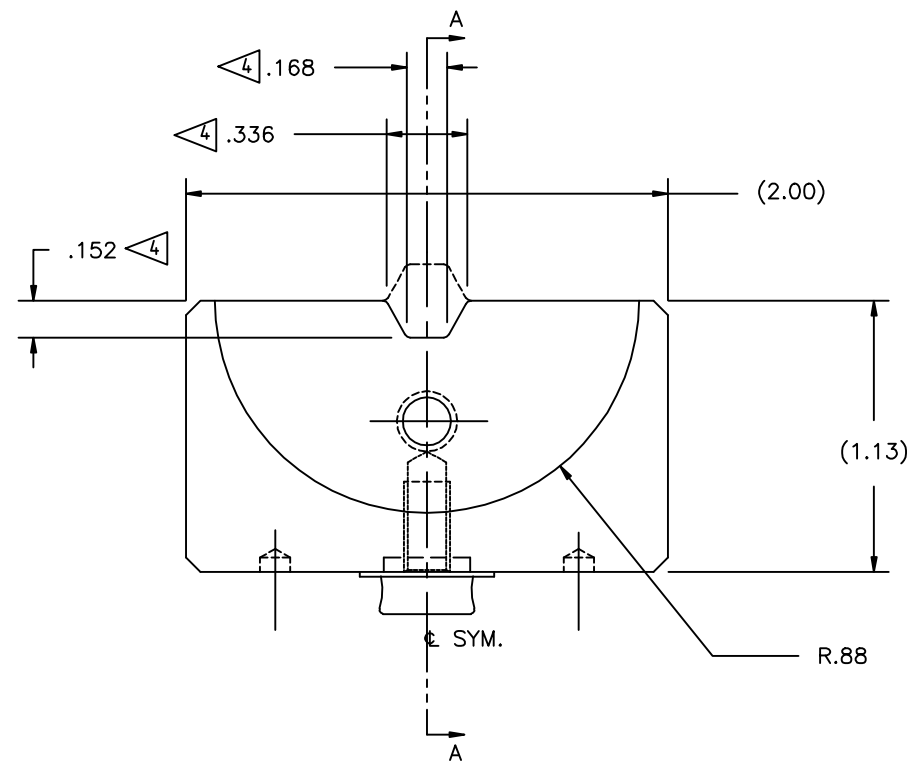

**UNCONTROLLED DOCUMENT
WILL NOT BE UPDATED**

- 4. THESE DIMENSIONS DO NOT FORM A STANDARD 30° HEX.
 - 3. REMOVE RETAINER PLATE WHEN USED IN TBM 12 HEAD.
 - 2. TO BE USED WITH THOMAS AND BETTS HEAD # 13642 OR TBM 12 HEAD TO CRIMP TERMINALS PER BAC 5153 AND CRIMP CONTACTS PER BAC 5162-7.
- NOTES: 1. THIS IS AN AUTOCAD DRAWING DO NOT CHANGE MANUALLY.

				<small>THESE DRAWINGS, SPECIFICATIONS OR OTHER DATA ARE AND REMAIN THE PROPERTY OF ASTRO TOOL CORP. AND MUST BE RETURNED UPON REQUEST. THEY CONTAIN INFORMATION OWNED AND/OR DEVELOPED BY ASTRO AT ITS OWN PRIVATE EXPENSE AND MAY NOT BE USED, DUPLICATED OR DISCLOSED TO OTHERS, IN WHOLE OR PART FOR DESIGN, MANUFACTURE OR PROCUREMENT WITHOUT THE WRITTEN PERMISSION OF ASTRO TOOL CORP. EACH AND EVERY TIME.</small>		SCALE: N.T.S. DWN BY: DYO DATE: 02-01-10 APPROVED:	UNLESS OTHERWISE SPECIFIED: DECIMALS: .XXX ± .005 .XX ± .010 .X ± .030 ANGLES: ± 1°	CAGE 58164 ASTRO TOOL CORP. 21615 S.W. TUALATIN VALLEY HWY., BEAVERTON OR 97006 DESCRIPTION: ENVELOPE DRAWING: ST2354-2 SWAGING TOOL PART NO. C ST2354-2-ENV
REV.	DESCRIPTION	BY	DATE	APR.				
A	NEW RELEASE.	DYO	02-01-10	MMK				