



Chipsmall Limited consists of a professional team with an average of over 10 year of expertise in the distribution of electronic components. Based in Hongkong, we have already established firm and mutual-benefit business relationships with customers from,Europe,America and south Asia,supplying obsolete and hard-to-find components to meet their specific needs.

With the principle of “Quality Parts,Customers Priority,Honest Operation,and Considerate Service”,our business mainly focus on the distribution of electronic components. Line cards we deal with include Microchip,ALPS,ROHM,Xilinx,Pulse,ON,Everlight and Freescale. Main products comprise IC,Modules,Potentiometer,IC Socket,Relay,Connector.Our parts cover such applications as commercial,industrial, and automotives areas.

We are looking forward to setting up business relationship with you and hope to provide you with the best service and solution. Let us make a better world for our industry!



## Contact us

Tel: +86-755-8981 8866 Fax: +86-755-8427 6832

Email & Skype: info@chipsmall.com Web: www.chipsmall.com

Address: A1208, Overseas Decoration Building, #122 Zhenhua RD., Futian, Shenzhen, China



3.3 V powered, 15 kV ESD protected, up to 12 Mbps RS-485/  
RS-422 transceiver

Datasheet - production data

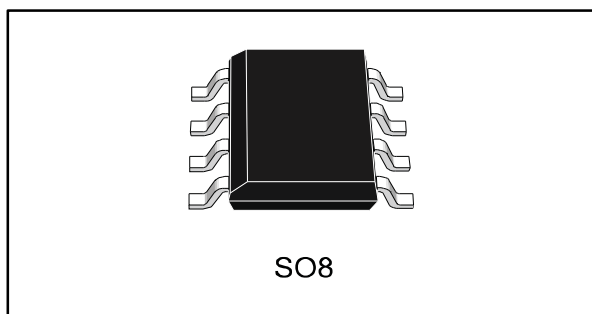

## Features

- ESD protection
  - ±15 kV IEC 61000-4-2 air discharge
  - ±8 kV IEC 61000-4-2 contact discharge
- Operate from a single 3.3 V supply - no charge pump required
- Interoperable with 5 V logic
- 1  $\mu$ A low current shutdown mode max.
- Guaranteed 12 Mbps data rate
- -7 to 12 V common mode input voltage range
- Half duplex versions available
- Industry standard 75176 pinout
- Current limiting and thermal shutdown for driver overload protection
- Guaranteed high receiver output state for floating inputs with no signal present
- Allow up to 64 transceivers on the bus
- Available in SO8 package
- Automotive grade (ST3485EIY)

## Description

The ST3485EB/EC/EI/EIY device is  $\pm 15$  kV ESD protected, 3.3 V low power transceiver for RS-485 and RS-422 communications. The device contains one driver and one receiver in half duplex configuration.

The ST3485E device transmits and receives at a guaranteed data rate of at least 12 Mbps.

All transmitter outputs and receiver inputs are protected to  $\pm 15$  kV IEC 61000-4-2 air discharge.

The driver is short-circuit current limited and is protected against excessive power dissipation by thermal shutdown circuitry that places the driver outputs into a high impedance state.

**Table 1: Device summary**

Order code	Temp range	Package	Packaging
ST3485ECDR	0 to 70 °C	SO8 (tape and reel)	2500 parts per reel
ST3485EBDR	-40 to 85 °C		
ST3485EIDT	-40 to 125 °C		
ST3485EIYDT			

## Contents

<b>1</b>	<b>Pin configuration</b> .....	<b>3</b>
<b>2</b>	<b>Truth tables</b> .....	<b>4</b>
<b>3</b>	<b>Maximum ratings</b> .....	<b>5</b>
<b>4</b>	<b>Electrical characteristics</b> .....	<b>6</b>
<b>5</b>	<b>Test circuits and typical characteristics</b> .....	<b>9</b>
<b>6</b>	<b>Package information</b> .....	<b>17</b>
	6.1    SO8 package information .....	18
	6.2    SO8 tape and reel information .....	19
<b>7</b>	<b>Ordering information</b> .....	<b>20</b>
<b>8</b>	<b>Revision history</b> .....	<b>21</b>

# 1 Pin configuration

Figure 1: Pin connections

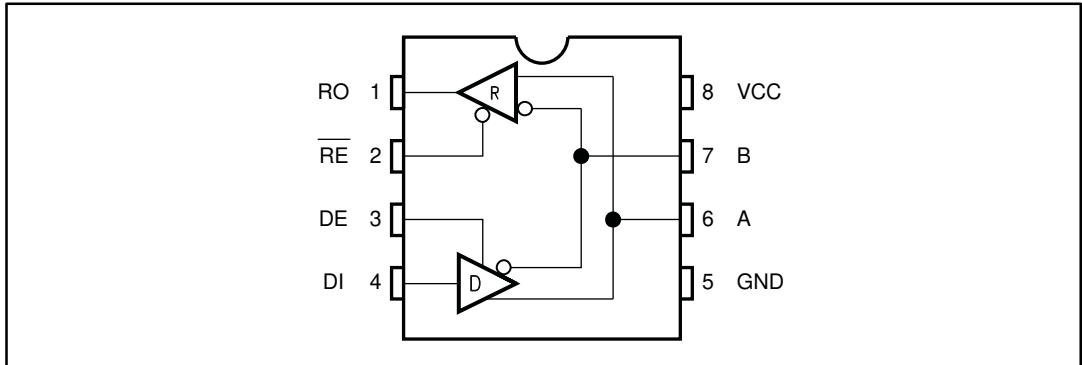

Table 2: Pin description

Pin n°	Symbol	Name and function
1	RO	Receiver output. If $A > B$ by 200 mV, RO will be high; if $A < B$ by 200 mV, RO will be low.
2	$\overline{RE}$	Receiver output enable. RO is enabled when $\overline{RE}$ is low; RO is high impedance when $\overline{RE}$ is high. If $\overline{RE}$ is high and DE is low, the device will enter a low power shutdown mode.
3	DE	Driver output enable. The driver outputs are enabled by bringing DE high. They are high impedance when DE is low. If $\overline{RE}$ is high DE is low, the device will enter a low-power shutdown mode. If the driver outputs are enabled, the part functions as line driver, while they are high impedance, it functions as line receivers if $\overline{RE}$ is low.
4	DI	Driver input. A low on DI forces output A low and output B high. Similarly, a high on DI forces output A high and output B low.
5	GND	Ground
6	A	Non-inverting receiver input and non-inverting driver output.
7	B	Inverting receiver input and inverting driver output.
8	VCC	Supply voltage: $V_{CC} = 3\text{ V to }3.6\text{ V}$ .

## 2 Truth tables

Table 3: Truth table (driver)

Inputs			Outputs		Mode
$\overline{RE}$	DE	DI	B	A	
X	H	H	L	H	Normal
		L	H	L	
L	L	X	Z	Z	
H					Shutdown

**Note:** X = “don’t care”; Z = high impedance

Table 4: Truth table (receiver)

Inputs			Output	Mode
$\overline{RE}$	DE	A-B	RO	
L	L	$\geq 0.2\text{ V}$	H	Normal
		$\leq -0.2\text{ V}$	L	
		Inputs open	H	
H		X	Z	Shutdown

**Note:** X = “don’t care”; Z = high impedance



### 3 Maximum ratings

Absolute maximum ratings are those values beyond which damage to the device may occur. Functional operation under these condition is not implied.

**Table 5: Absolute maximum ratings**

Symbol	Parameter	Value	Unit
$V_{CC}$	Supply voltage	7	V
$V_I$	Control input voltage ( $\overline{RE}$ , DE)	-0.3 to 7	
$V_{DI}$	Driver input voltage (DI)	-0.3 to 7	
$V_{DO}$	Driver output voltage (A, B)	$\pm 14$	
$V_{RI}$	Receiver input voltage (A, B)	$\pm 14$	
$V_{RO}$	Receiver output voltage (RO)	-0.3 to ( $V_{CC} + 0.3$ )	
ESD	HBM: human body model for the line inputs (A and B) <sup>(1)</sup>	12	kV
	HBM: human body model for the logic inputs (DI, DE, $\overline{RE}$ ) <sup>(1)</sup>	4	
	HBM: human body model for all other pins <sup>(1)</sup>	2	
	CDM: charged device model <sup>(2)</sup>	1.5	

**Notes:**

<sup>(1)</sup>Human body model: 100 pF discharged through a 1.5 k $\Omega$  resistor between two pins of the device, done for all couples of pin combinations with other pins floating.

<sup>(2)</sup>Charged device model: all pins plus package are charged together to the specified voltage and then discharged directly to ground.

## 4 Electrical characteristics

**Table 6: Electrical characteristics (VCC = 3 V to 3.6 V, TA = 0 to 70 °C for ST3485ECDR, TA = -40 to 85 °C for ST3485EBDR, TA = -40 to 125 °C for ST3485EIDT and ST3485EIYDT, unless otherwise specified. Typical values are referred to TA = 25 °C)**

Symbol	Parameter	Test conditions	Min.	Typ.	Max.	Unit	
ISUPPLY	VCC power supply current	No load, DI = 0 V or VCC	—	DE = VCC, $\overline{RE}$ = 0 V or VCC	1.3	2.2	mA
				DE = 0 V, $\overline{RE}$ = 0 V	1.2	1.9	
ISHDN	Shutdown supply current	DE = 0 V, $\overline{RE}$ = VCC, DI = 0 V or VCC		0.002	1	μA	

**Table 7: Logic input electrical characteristics (VCC = 3 V to 3.6 V, TA = 0 to 70 °C for ST3485ECDR, TA = -40 to 85 °C for ST3485EBDR, TA = -40 to 125 °C for ST3485EIDT and ST3485EIYDT, unless otherwise specified. Typical values are referred to TA = 25 °C)**

Symbol	Parameter	Test conditions	Min.	Typ.	Max.	Unit
VIL	Input logic threshold low	DE, DI, $\overline{RE}$		1.3	0.8	V
VIH	Input logic threshold high	DE, DI, $\overline{RE}$	2			
IIN1	Logic input current	DE, DI, $\overline{RE}$			±2.0	μA
IIN2	Input current (A, B)	DE = 0 V, VCC = 0 or 3.6 V	VIN = 12 V		1	mA
			VIN = -7 V		-0.8	

**Table 8: Transmitter electrical characteristics (VCC = 3 V to 3.6 V, TA = 0 to 70 °C for ST3485ECDR, TA = -40 to 85 °C for ST3485EBDR, TA = -40 to 125 °C for ST3485EIDT and ST3485EIYDT, unless otherwise specified. Typical values are referred to TA = 25 °C)**

Symbol	Parameter	Test conditions	Min.	Typ.	Max.	Unit
VOD	Differential drive output	RL = 100 Ω (RS-422) ( <i>Figure 2</i> )	2	—		V
		RL = 54 Ω (RS-485) ( <i>Figure 2</i> )	1.5			
		RL = 60 Ω (RS-485) ( <i>Figure 3</i> )	1.5			
ΔVOD	Change in magnitude of driver differential output voltage for complementary output states <sup>(1)</sup>	RL = 54 Ω or 100 Ω ( <i>Figure 2</i> )			0.2	
VOC	Driver common mode output voltage	RL = 54 Ω or 100 Ω ( <i>Figure 2</i> )			3	
ΔVOC	Change in magnitude of driver common mode output voltage <sup>(1)</sup>	RL = 54 Ω or 100 Ω ( <i>Figure 2</i> )			0.2	
IosD	Driver short-circuit output current				±250	mA

### Notes:

<sup>(1)</sup>ΔVOD and ΔVOC are the changes in VOD and VOC, respectively, when the DI input changes state.

**Table 9: Receiver electrical characteristics (VCC = 3 V to 3.6 V, TA = 0 to 70 °C for ST3485ECDR, TA = -40 to 85 °C for ST3485EBDR, TA = -40 to 125 °C for ST3485EIDT and ST3485EIYDT, unless otherwise specified. Typical values are referred to TA = 25 °C)**

Symbol	Parameter	Test conditions	Min.	Typ.	Max.	Unit
V <sub>TH</sub>	Receiver differential threshold voltage	V <sub>CM</sub> = -7 V to 12 V, DE = 0	-0.2		0.2	V
ΔV <sub>TH</sub>	Receiver input hysteresis	V <sub>CM</sub> = 0 V		70		mV
V <sub>OH</sub>	Receiver output high voltage	I <sub>OUT</sub> = -4 mA, V <sub>ID</sub> = 200 mV (Figure 4)	2			V
V <sub>OL</sub>	Receiver output low voltage	I <sub>OUT</sub> = 4 mA, V <sub>ID</sub> = -200 mV (Figure 4)			0.4	
I <sub>OZR</sub>	3-state (high impedance) output current at receiver	V <sub>CC</sub> = 3.6 V, V <sub>O</sub> = 0 V to V <sub>CC</sub>			±1	μA
R <sub>RIN</sub>	Receiver input resistance	V <sub>CM</sub> = -7 V to 12 V	24			kΩ
I <sub>OSR</sub>	Receiver short-circuit current	V <sub>RO</sub> = 0 V to V <sub>CC</sub>	7		60	mA

**Table 10: Driver switching characteristics (VCC = 3 V to 3.6 V, TA = 0 to 70 °C for ST3485ECDR, TA = -40 to 85 °C for ST3485EBDR, TA = -40 to 125 °C for ST3485EIDT and ST3485EIYDT, unless otherwise specified. Typical values are referred to TA = 25 °C)**

Symbol	Parameter	Test conditions	Min.	Typ.	Max.	Unit
D <sub>R</sub>	Maximum data rate		12	15		Mbps
t <sub>DD</sub>	Differential output delay	R <sub>L</sub> = 60 Ω, C <sub>L</sub> = 15 pF (Figure 5 and Figure 6)		18	30	ns
t <sub>TD</sub>	Differential output transition time	R <sub>L</sub> = 60 Ω, C <sub>L</sub> = 15 pF (Figure 5 and Figure 6)		12	20	
t <sub>PLH</sub> t <sub>PHL</sub>	Propagation delay	R <sub>L</sub> = 27 Ω, C <sub>L</sub> = 15 pF (Figure 9 and Figure 10)		18	30	
t <sub>PDS</sub>	t <sub>PLH</sub> - t <sub>PHL</sub>   driver propagation delay skew <sup>(1)</sup>	R <sub>L</sub> = 27 Ω, C <sub>L</sub> = 15 pF (Figure 9 and Figure 10)		2	5	
t <sub>PZL</sub>	Output enable time	R <sub>L</sub> = 110 Ω (Figure 11 and Figure 12)		19	35	
t <sub>PZH</sub>	Output enable time	R <sub>L</sub> = 110 Ω (Figure 7 and Figure 8)		30	50	
t <sub>PHZ</sub>	Output disable time	R <sub>L</sub> = 110 Ω (Figure 7 and Figure 8)		19	35	
t <sub>PLZ</sub>	Output disable time	R <sub>L</sub> = 110 Ω (Figure 11 and Figure 12)		30	50	
t <sub>SKREW</sub>	Differential output delay skew			1	3	
t <sub>PSH</sub>	Driver enable from shutdown to output high	R <sub>L</sub> = 110 Ω (Figure 7 and Figure 8)		30	50	
t <sub>PSL</sub>	Driver enable from shutdown to output low	R <sub>L</sub> = 110 Ω (Figure 11 and Figure 12)		19	35	

**Notes:**

<sup>(1)</sup>Measured on |t<sub>PLH</sub>(A)-t<sub>PHL</sub>(A)| and |t<sub>PLH</sub>(B)-t<sub>PHL</sub>(B)|.



**Table 11: Receiver switching characteristics (VCC = 3 V to 3.6 V, TA = 0 to 70 °C for ST3485ECDR, TA = -40 to 85 °C for ST3485EBDR, TA = -40 to 125 °C for ST3485EIDT and ST3485EIYDT, unless otherwise specified. Typical values are referred to TA = 25 °C)**

Symbol	Parameter	Test conditions	Min.	Typ.	Max.	Unit
t <sub>RPLH</sub> , t <sub>RPHL</sub>	Propagation delay	V <sub>ID</sub> = 0 V to 3 V, C <sub>L</sub> = 15 pF ( <i>Figure 13</i> and <i>Figure 14</i> )	—	30	50	ns
t <sub>RPDS</sub>	t <sub>RPLH</sub> - t <sub>RPHL</sub>   receiver propagation delay skew	V <sub>ID</sub> = 0 V to 3 V, C <sub>L</sub> = 15 pF ( <i>Figure 13</i> and <i>Figure 14</i> )		1	3	
t <sub>PRZL</sub>	Receiver output enable time to low level	C <sub>L</sub> = 15 pF ( <i>Figure 15</i> and <i>Figure 17</i> )		10	20	
t <sub>PRZH</sub>	Receiver output enable time to high level	C <sub>L</sub> = 15 pF ( <i>Figure 15</i> and <i>Figure 16</i> )		10	20	
t <sub>PRHZ</sub>	Receiver output disable time from high level	C <sub>L</sub> = 15 pF ( <i>Figure 15</i> and <i>Figure 18</i> )		10	20	
t <sub>PRLZ</sub>	Receiver output disable time from low level	C <sub>L</sub> = 15 pF ( <i>Figure 15</i> and <i>Figure 19</i> )		10	20	
t <sub>PRSH</sub>	Receiver output enable time from shutdown to high level	C <sub>L</sub> = 15 pF ( <i>Figure 15</i> and <i>Figure 16</i> )		10	20	
t <sub>PRSL</sub>	Receiver output enable time from shutdown to low level	C <sub>L</sub> = 15 pF ( <i>Figure 15</i> and <i>Figure 17</i> )		20	40	μs

**Notes:**

1. ΔV<sub>OD</sub> and ΔV<sub>OC</sub> are the changes in V<sub>OD</sub> and V<sub>OC</sub>, respectively, when the DI input changes state.
2. Measured on |t<sub>PLH</sub>(A) - t<sub>PHL</sub>(A)| and |t<sub>PLH</sub>(B) - t<sub>PHL</sub>(B)|.
3. The transceivers are put into shutdown by bring  $\overline{RE}$  high and DE low. If the input are in state for less than 80 ns, the part are guaranteed not to enter shutdown. If the inputs are in this state for at least 300 ns, the parts are guaranteed to have entered shutdown.

## 5 Test circuits and typical characteristics

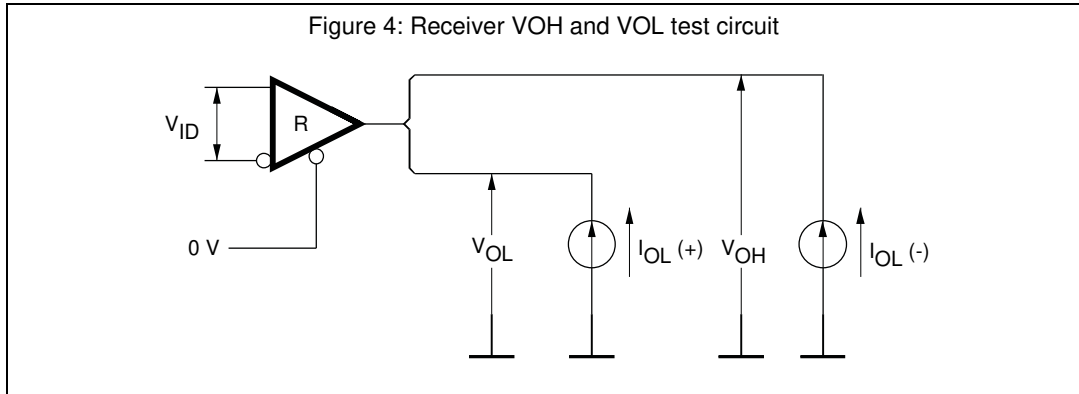
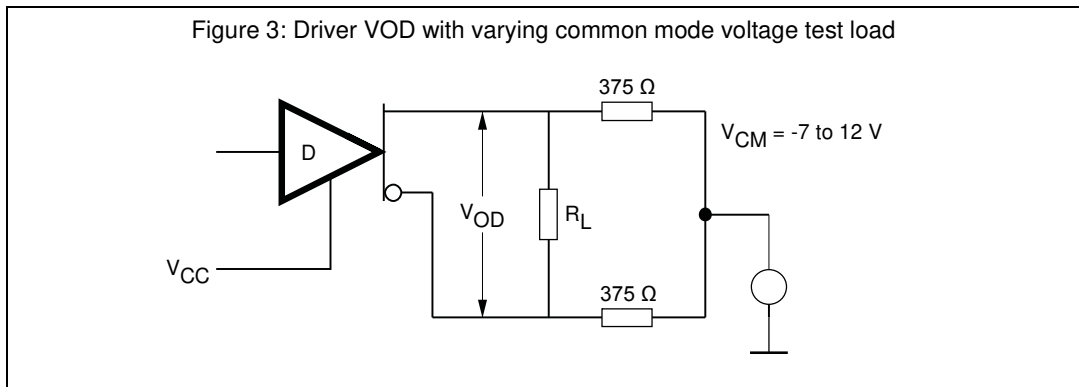
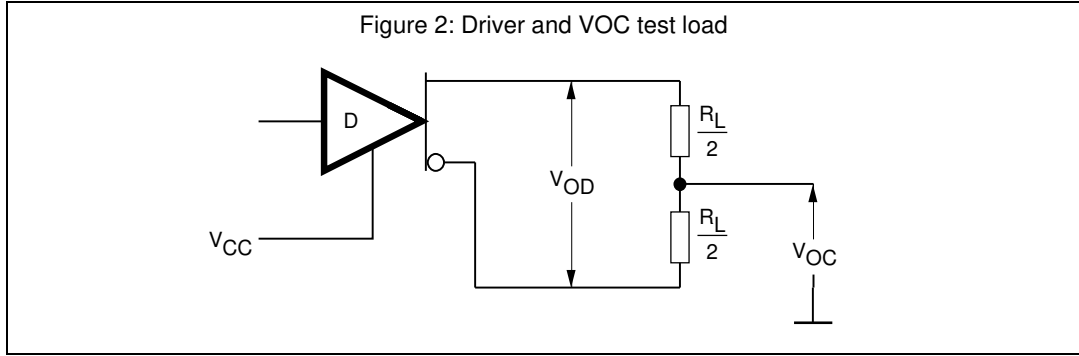

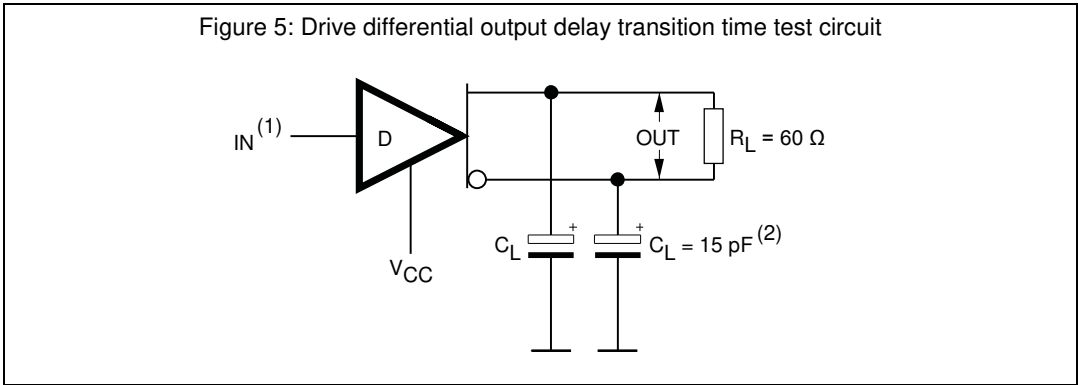

1. The input pulse is supplied by a generator with the following characteristics: PRR = 250 kHz, 50 % duty cycle,  $t_r \leq 6.0$  ns,  $Z_o = 50 \Omega$ .
2.  $C_L$  includes probe and stray capacitance

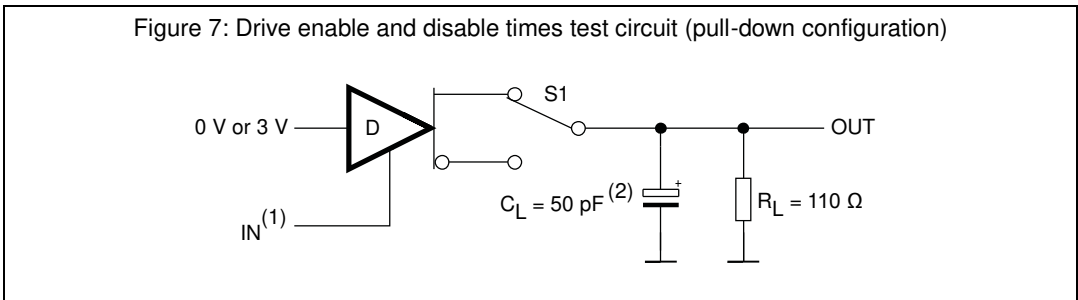
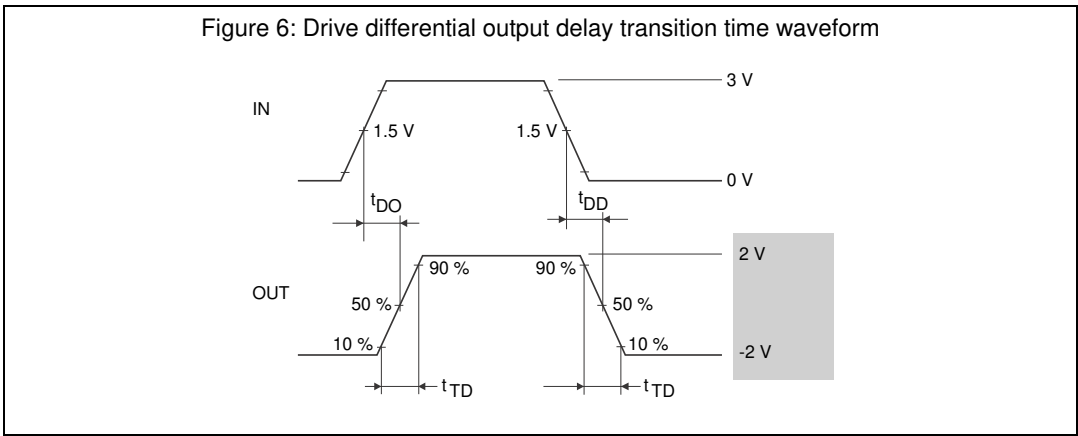

1. The input pulse is supplied by a generator with the following characteristics: PRR = 250 kHz, 50 % duty cycle,  $t_r \leq 6.0$  ns.
2.  $C_L$  includes probe and stray capacitance

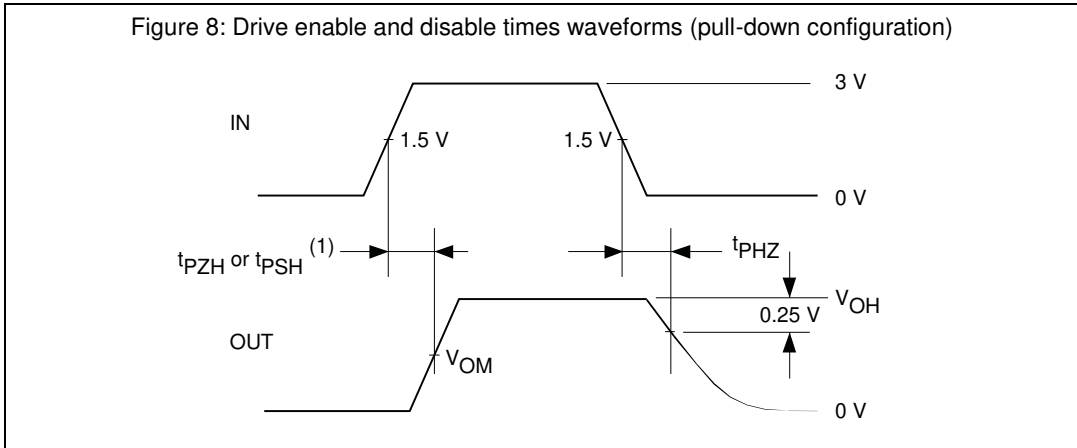

1.  $t_{PZH}$  is valid if the driver is initially disabled ( $\overline{RE}$  is high),  $t_{PSH}$  is valid if the driver is initially in shutdown mode (RE is low).

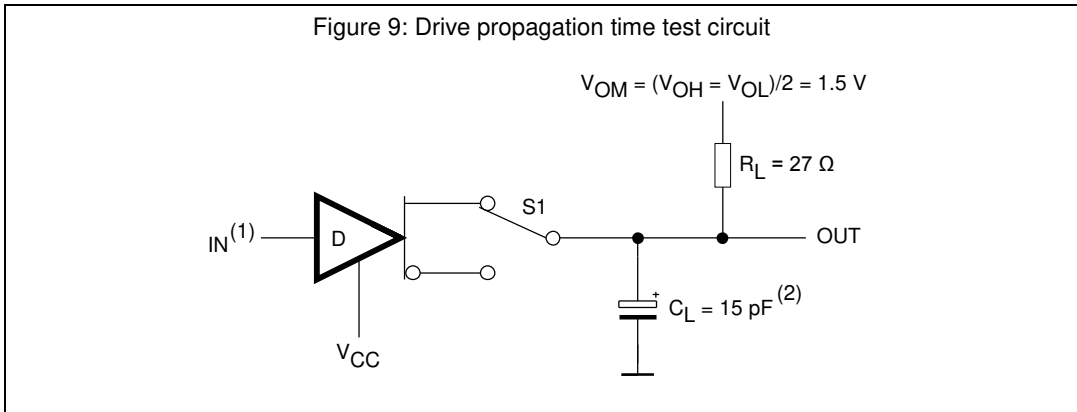

1. The input pulse is supplied by a generator with the following characteristics: PRR = 250 kHz, 50 % duty cycle,  $t_r \leq 6.0$  ns.
2.  $C_L$  includes probe and stray capacitance

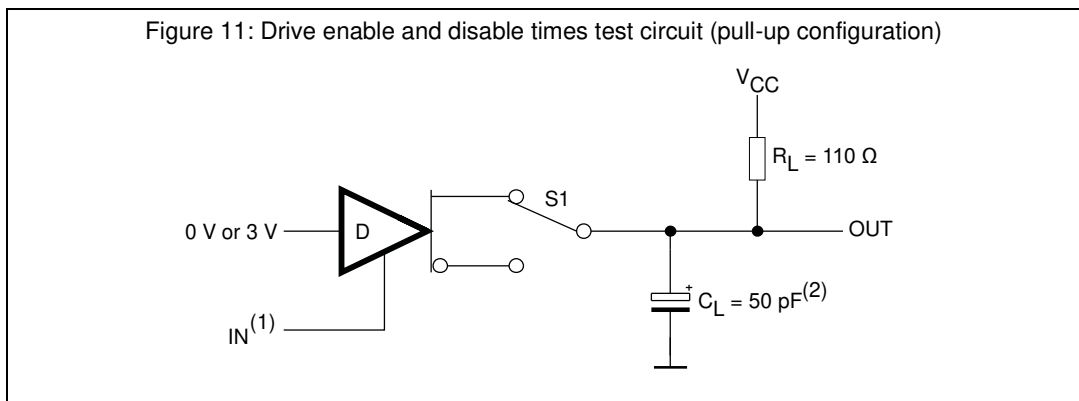
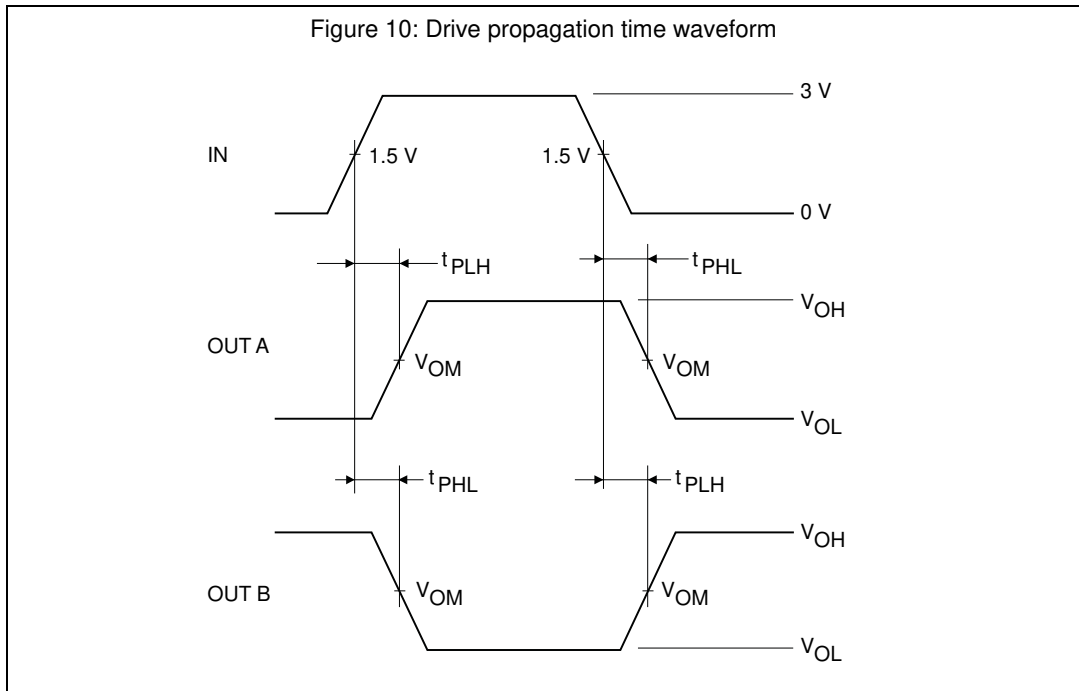

1. The input pulse is supplied by a generator with the following characteristics: PRR = 250 kHz, 50 % duty cycle,  $t_r \leq 6.0 \text{ ns}$ .
2.  $C_L$  includes probe and stray capacitance

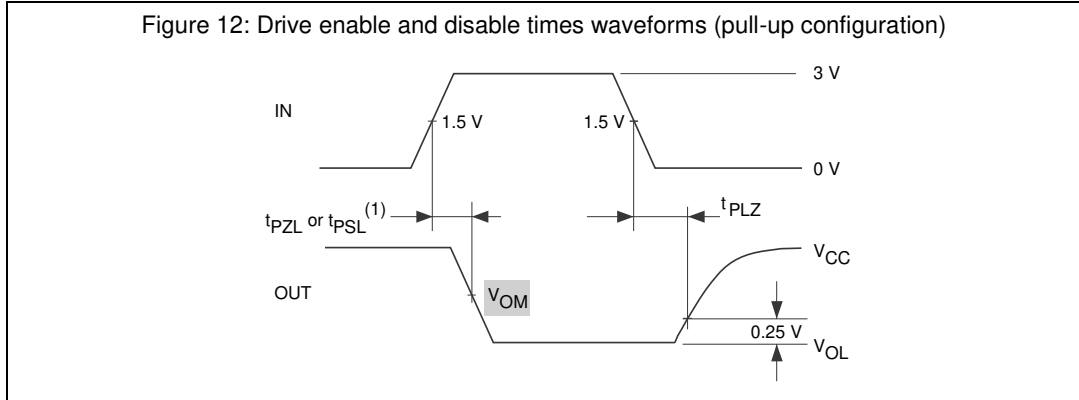

1.  $t_{PZL}$  is valid if the driver is initially disabled ( $\overline{RE}$  is high),  $t_{PSL}$  is valid if the driver is initially in shutdown mode (RE is low).

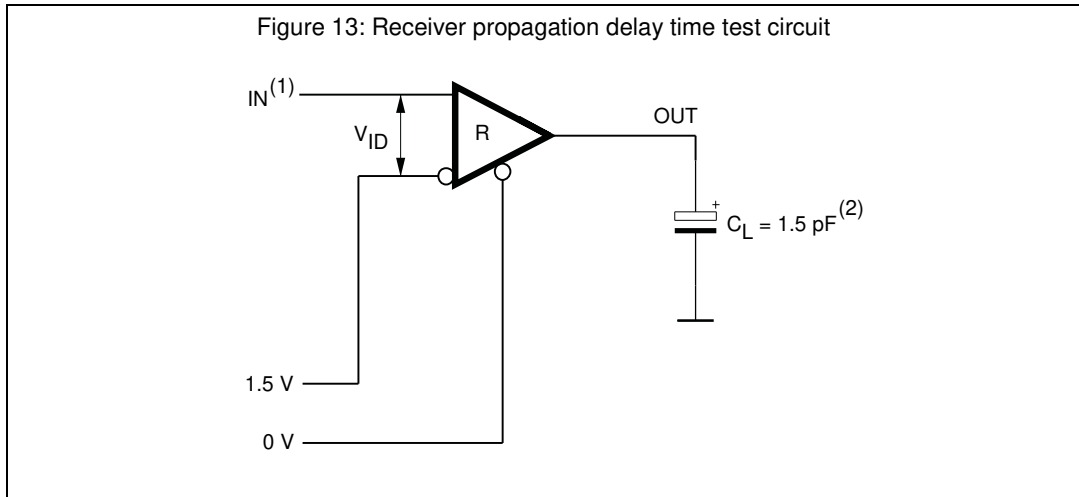

1. The input pulse is supplied by a generator with the following characteristics: PRR = 250 kHz, 50 % duty cycle,  $t_r \leq 6.0$  ns.
2.  $C_L$  includes probe and stray capacitance

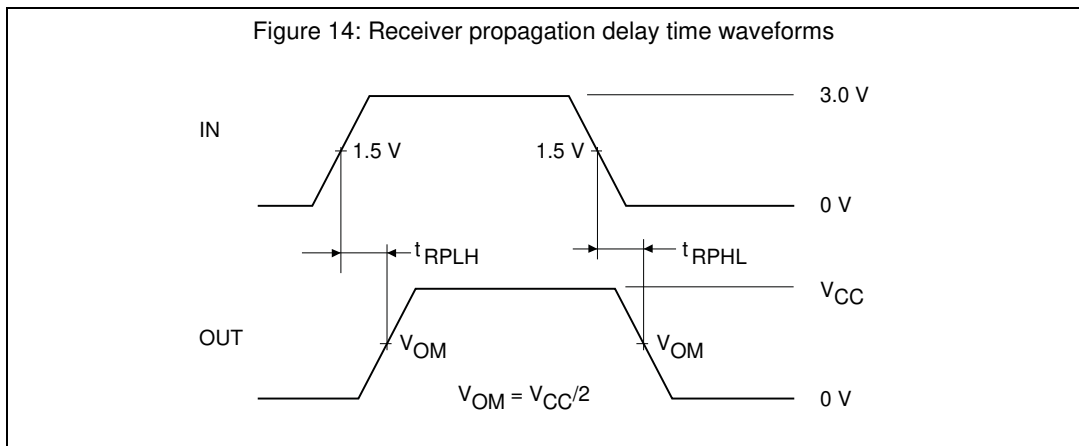



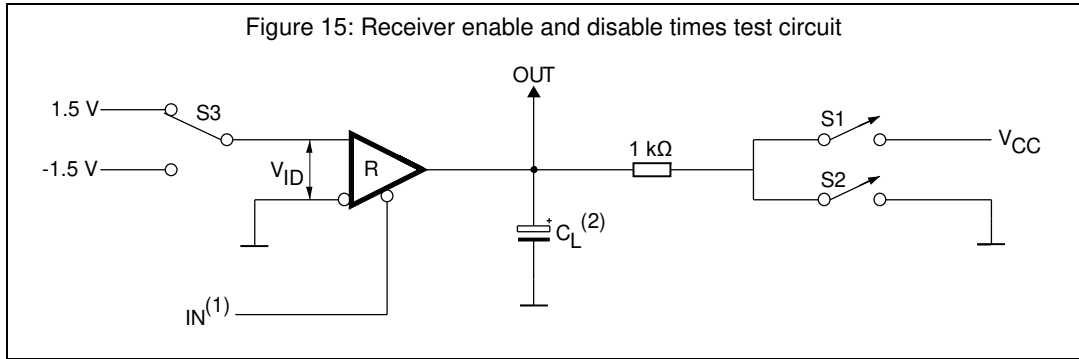

1. The input pulse is supplied by a generator with the following characteristics: PRR = 250 kHz, 50 % duty cycle,  $t_r \leq 6.0$  ns.
2.  $C_L$  includes probe and stray capacitance

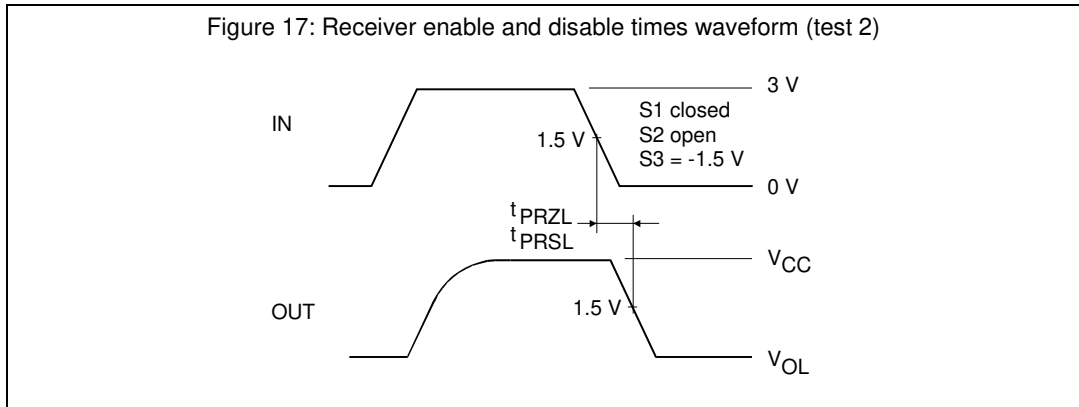
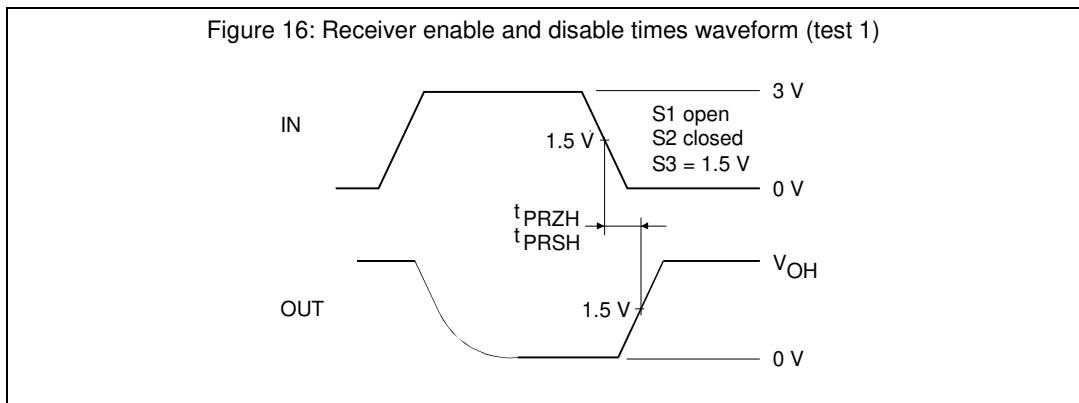

Figure 18: Receiver enable and disable times waveform (test 3)

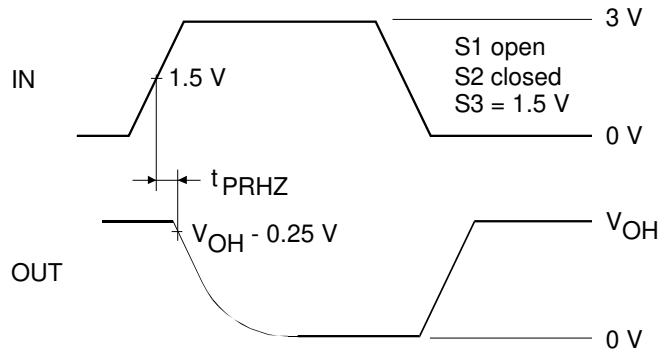

Figure 19: Receiver enable and disable times waveform (test 4)

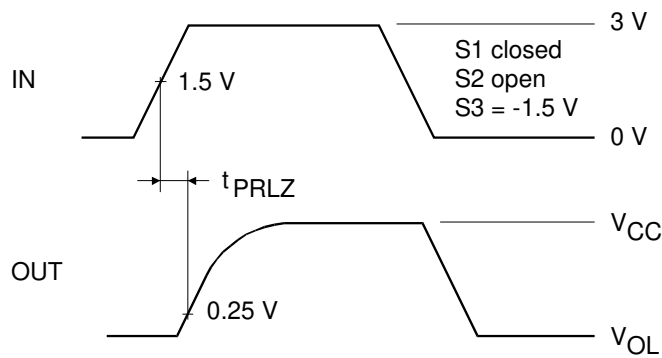

Figure 20: Receiver output current vs. output low voltage

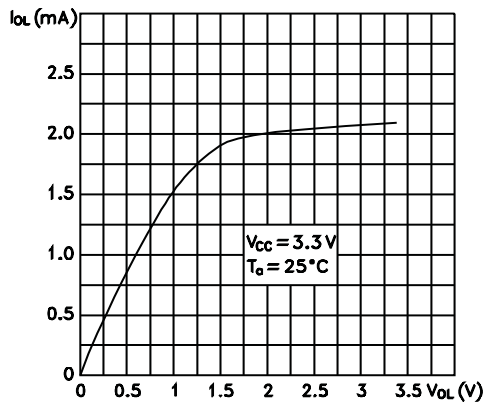

Figure 21: Receiver output current vs. output high voltage

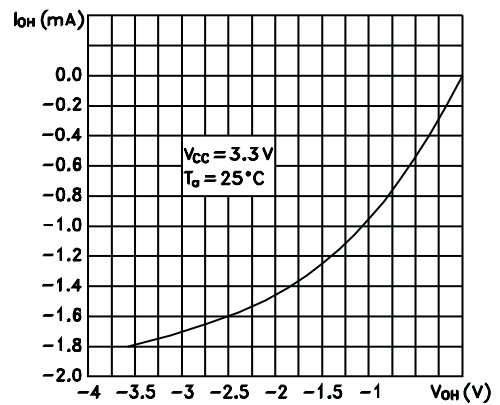

Figure 22: Low level driver output capability

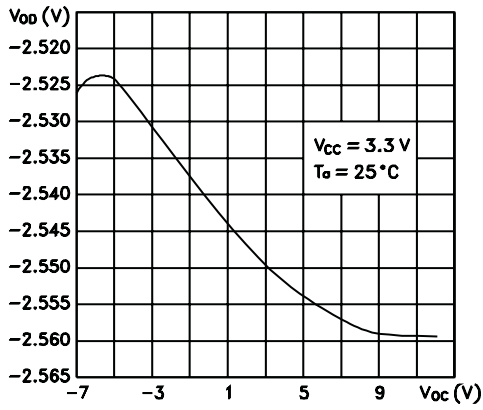

Figure 23: High level driver output capability

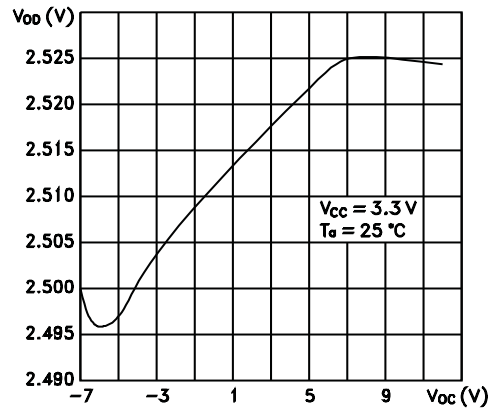

Figure 24: Receiver input characteristics

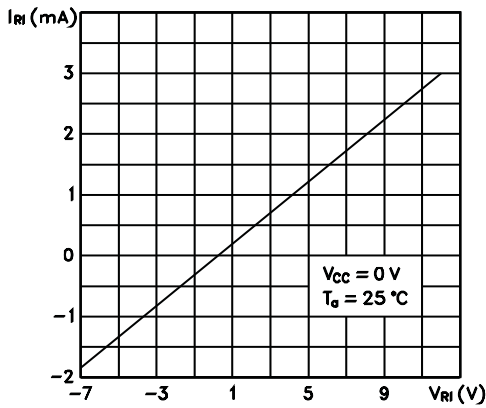

Figure 25: Driver short-circuit current (test 1)

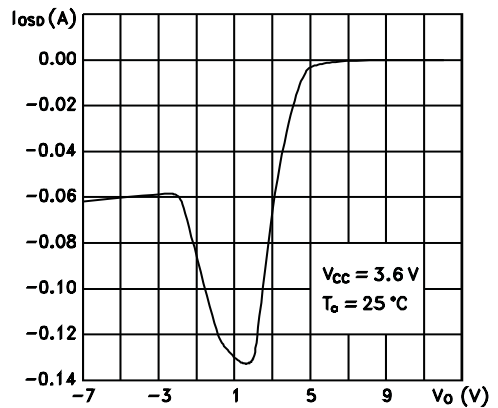
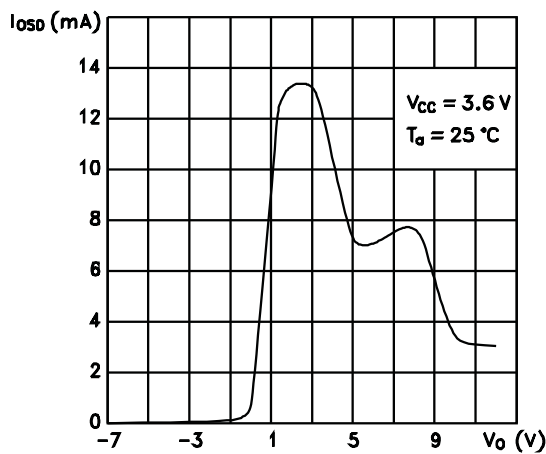

Figure 26: Driver short-circuit current (test 2)



## 6 Package information

In order to meet environmental requirements, ST offers these devices in different grades of ECOPACK® packages, depending on their level of environmental compliance. ECOPACK® specifications, grade definitions and product status are available at: [www.st.com](http://www.st.com). ECOPACK® is an ST trademark.

### 6.1 SO8 package information

Figure 27: SO8 package outline

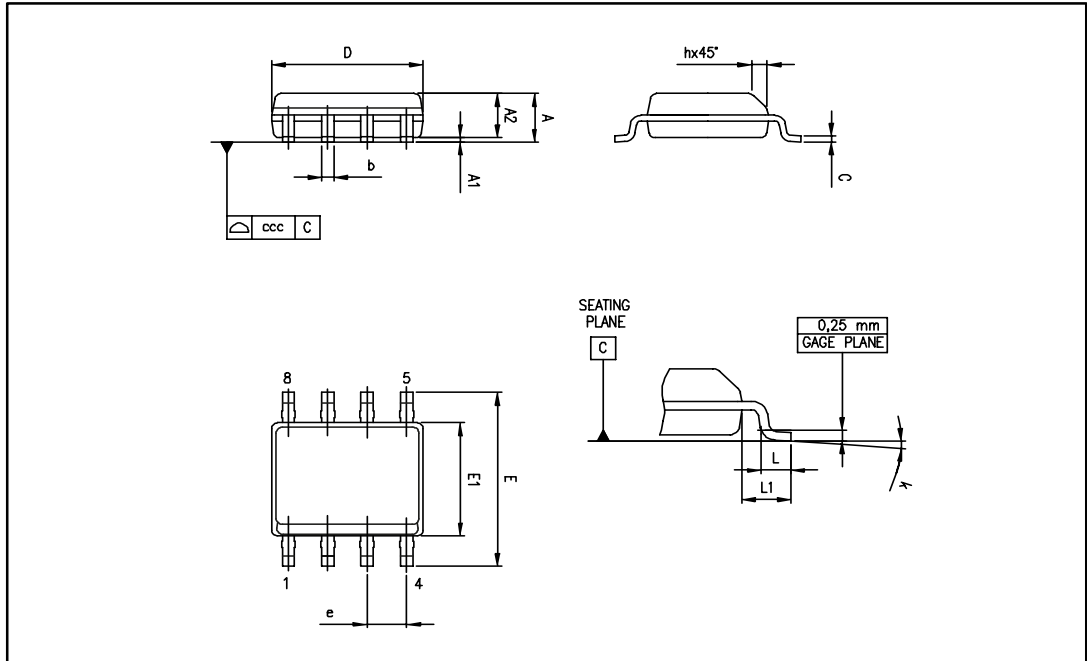
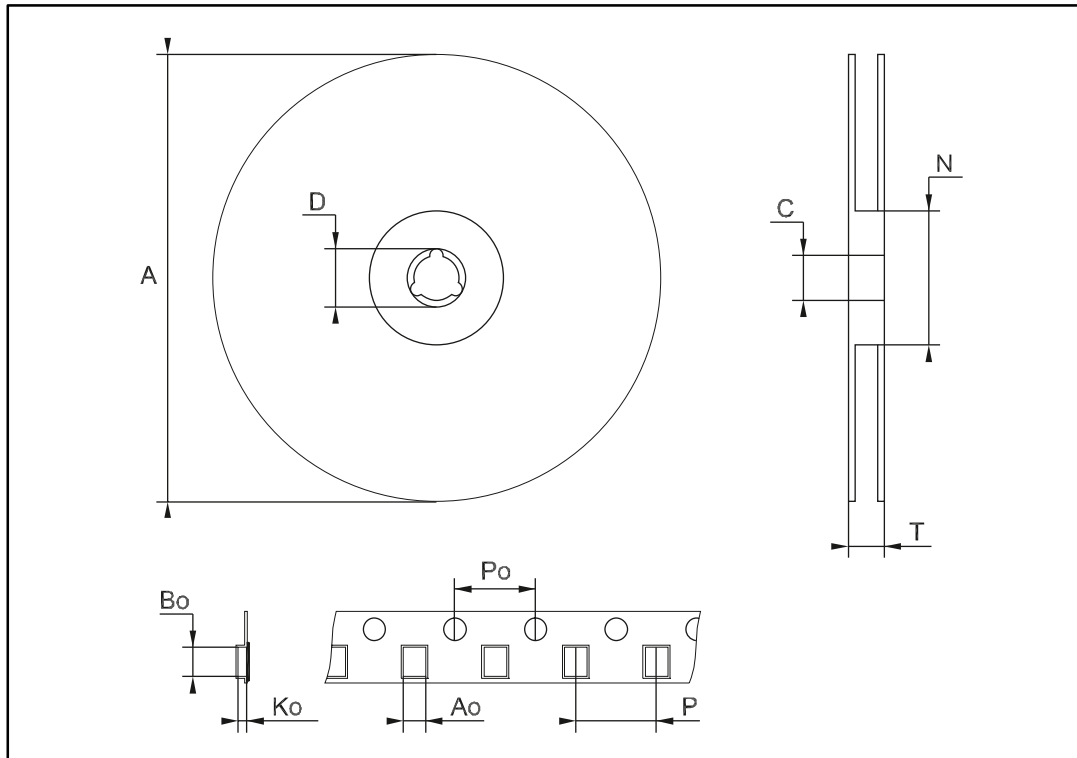

Table 12: SO8 mechanical data

Ref.	Dimensions					
	Millimeters			Inches		
	Min.	Typ.	Max.	Min.	Typ.	Max
A			1.75			0.069
A1	0.10		0.25	0.004		0.010
A2	1.25			0.049		
b	0.28		0.48	0.011		0.019
c	0.17		0.23	0.007		0.010
D	4.80	4.90	5.00	0.189	0.193	0.197
E	5.80	6.00	6.20	0.228	0.236	0.244
E1	3.80	3.90	4.00	0.150	0.154	0.157
e		1.27			0.050	
h	0.25		0.50	0.010		0.020
L	0.40		1.27	0.016		0.050
L1		1.04			0.040	
k	1°		8°	1°		8°
ccc			0.10			0.004

## 6.2 SO8 tape and reel information

Figure 28: SO8 tape and reel outline



1. Drawing not to scale

Table 13: SO8 tape and reel mechanical data

Symbol	Dimensions					
	mm			inch		
	Min.	Typ.	Max.	Min.	Typ.	Max.
A			330			12.992
C	12.8		13.2	0.504		0.519
D	20.2			0.795		
N	60			2.362		
T			22.4			0.882
Ao	8.1	—	8.5	0.319	—	0.335
Bo	5.5		5.9	0.216		0.232
Ko	2.1		2.3	0.082		0.090
Po	3.9		4.1	0.153		0.161
P	7.9		8.1	0.311		0.319



## 7 Ordering information

Table 14: Order codes

Order code	Temperature range	Package	Packaging	Marking
ST3485ECDR	0 to 70 °C	SO8	Tape and reel	3485EC
ST3485EBDR	-40 to 85 °C			3485EB
ST3485EIDT	-40 to 125 °C			3485EI
ST3485EIYDT <sup>(1)</sup>	-40 to 125 °C (automotive grade)			3485EIY

**Notes:**

<sup>(1)</sup>Qualification and characterization according to AEC Q100 and Q003 or equivalent, advanced screening according to AEC Q001 and Q 002 or equivalent.

## 8 Revision history

**Table 15: Document revision history**

Date	Revision	Changes
20-Jun-2005	2	Mistake on table 12 $t_{ZL(SHDN)}$ ms ==> $\mu$ s.
30-Aug-2005	3	Remove (TRUE) on title, description has been updated in cover page. The $V_{TH}$ and $DV_{TH}$ values are changed in table 10.
07-Apr-2006	4	Order codes updated.
12-Nov-2007	5	Added Table 1.
18-Dec-2013	6	<p>Updated Features (added SO-8 package, replaced human body model by <math>\pm 15</math> kV IEC 61000-4-2 air discharge and IEC 1000-4-2 by IEC 61000-4-2).</p> <p>Updated Description (renamed device to ST3485EB/EC, replaced human body model by <math>\pm 15</math> kV IEC 61000-4-2 air discharge).</p> <p>Removed ST3485ECN device from Table 1.</p> <p>Updated title of Table 6, cross-references, replaced human body model (HBM) by <math>\pm 15</math> kV IEC 61000-4-2 air discharge and IEC 1000-4-2 by IEC 61000-4-2.</p> <p>Added notes below Table 9.</p> <p>Updated Table 10 to Table 12 (updated data, cross-references).</p> <p>Updated Figure 5 to Figure 16 (updated data, added notes below figures, highlighted some parts of Figure 6 and Figure 12).</p> <p>Removed DIP-8 package from Section 6: "Package information" and whole document. Reformatted Section 6: "Package information" (added Figure 27, Figure 28, Table 13 and Table 14, reversed order of figures and table).</p> <p>Minor corrections throughout document.</p>
12-Jun-2015	7	<p>Added part number ST3485EIY</p> <p>Added order code ST3485EIYDT and pointed out in Features it is automotive grade.</p> <p>Table 7 and Table 9 through to Table 12: replaced <math>T_A = -40</math> to <math>85</math> °C with <math>T_A = 0</math> to <math>70</math> °C (ST3485ECDR), <math>T_A = -40</math> to <math>85</math> °C (ST3485EBDR), and <math>T_A = -40</math> to <math>125</math> °C (ST3485EIYDT).</p> <p>Updated titles of figures 7, 8, 11, 12, 16, 17, 18, 19, 25, and 26</p>
15-Mar-2016	8	<p>Table 5: added ESD information</p> <p>Removed "Table 6: ESD performance: transmitter outputs, receiver inputs (A, B)".</p> <p>Added Section 7: "Ordering information"</p>
02-Aug-2016	9	<p>Added new part number ST3485EI</p> <p>Table 1: "Device summary": added information for new part number ST3485EI.</p> <p>Removed "<b>Note</b>" icons throughout datasheet</p> <p>Section 4: "Electrical characteristics": updated <math>T_A</math> information</p> <p>Section 5: "Test circuits and typical characteristics": removed overline bar concerning "RE is low" in note 1 of figures 8 and 12.</p> <p>Table 14: "Order codes": added ST3485EIDT and updated footnote 1 (ST3485EIYDT now qualified).</p>
25-Aug-2016	10	<i>Table 14: "Order codes"</i> : updated order codes ST3485EBDR and ST3485ECDR.

**IMPORTANT NOTICE – PLEASE READ CAREFULLY**

STMicroelectronics NV and its subsidiaries ("ST") reserve the right to make changes, corrections, enhancements, modifications, and improvements to ST products and/or to this document at any time without notice. Purchasers should obtain the latest relevant information on ST products before placing orders. ST products are sold pursuant to ST's terms and conditions of sale in place at the time of order acknowledgement.

Purchasers are solely responsible for the choice, selection, and use of ST products and ST assumes no liability for application assistance or the design of Purchasers' products.

No license, express or implied, to any intellectual property right is granted by ST herein.

Resale of ST products with provisions different from the information set forth herein shall void any warranty granted by ST for such product.

ST and the ST logo are trademarks of ST. All other product or service names are the property of their respective owners.

Information in this document supersedes and replaces information previously supplied in any prior versions of this document.

© 2016 STMicroelectronics – All rights reserved