



Chipsmall Limited consists of a professional team with an average of over 10 year of expertise in the distribution of electronic components. Based in Hongkong, we have already established firm and mutual-benefit business relationships with customers from,Europe,America and south Asia,supplying obsolete and hard-to-find components to meet their specific needs.

With the principle of "Quality Parts,Customers Priority,Honest Operation,and Considerate Service",our business mainly focus on the distribution of electronic components. Line cards we deal with include Microchip,ALPS,ROHM,Xilinx,Pulse,ON,Everlight and Freescale. Main products comprise IC,Modules,Potentiometer,IC Socket,Relay,Connector.Our parts cover such applications as commercial,industrial, and automotives areas.

We are looking forward to setting up business relationship with you and hope to provide you with the best service and solution. Let us make a better world for our industry!



Contact us

Tel: +86-755-8981 8866 Fax: +86-755-8427 6832

Email & Skype: info@chipsmall.com Web: www.chipsmall.com

Address: A1208, Overseas Decoration Building, #122 Zhenhua RD., Futian, Shenzhen, China





ST730A

5V STEP-DOWN, CURRENT-MODE PWM DC-DC CONVERTERS

- UP TO 450mA LOAD CURRENTS
- 200kHz HIGH-FREQUENCY CURRENT-MODE PWM
- 85% TO 96% EFFICIENCIES
- 33 μ H OR 100 μ H PRE-SELECTED INDUCTOR VALUE, NO COMPONENT DESIGN REQUIRED
- 0.8mA QUIESCENT CURRENT
- 0.3 μ A SHUTDOWN SUPPLY CURRENT
- ADJUSTABLE OUTPUT VOLTAGE
- OVERCURRENT, SOFT-START AND UNDERVOLTAGE LOCKOUT PROTECTION
- CYCLE-BY-CYCLE CURRENT LIMITING
- PACKAGE AVAILABLE: DIP-8 AND SO-8

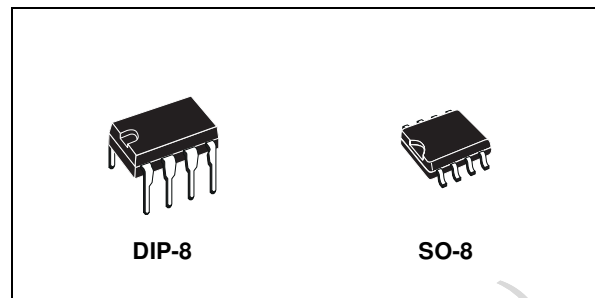

DESCRIPTION

The ST730A is a 5V output CMOS, step-down switching regulator. The ST730A accepts inputs between 5.2V and 11V and delivers 450mA. Typical efficiencies are 85% to 96%.

Quiescent supply current is 0.8mA and only 0.3 μ A in shutdown mode. The output does not exhibit frequency over this specified range. Pulse-width modulation (PWM) current-mode control provides

precise output regulation and excellent transient responses. Output voltage accuracy is guaranteed to be $\pm 5\%$ over line, load, and temperature variations.

Fixed-frequency switching, and absence of subharmonic ripple allows easy filtering of output ripple and noise, as well as the use of small external components. This regulators require only a single inductor value to work in most applications, so no inductor design is necessary. Typical applications are: Cellular phones & radios, portable Instruments, Portable Communications Equipments and Computer Peripherals.

SCHEMATIC DIAGRAM

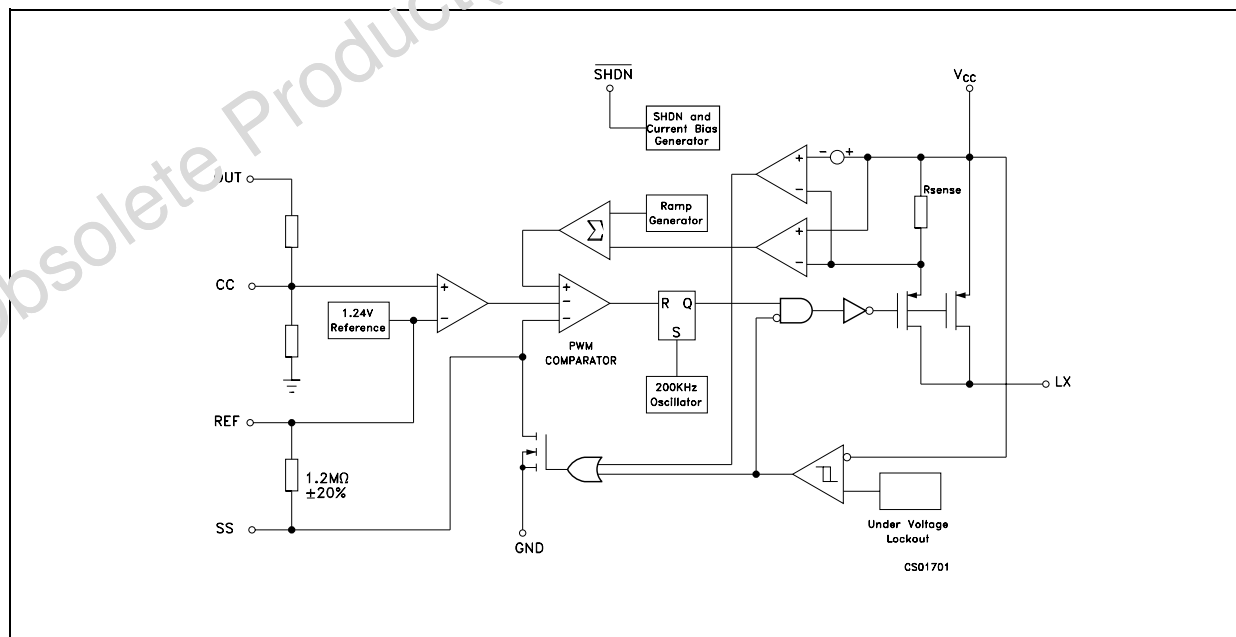

ABSOLUTE MAXIMUM RATINGS

Symbol	Parameter ²	Value	Unit
V _{CC}	DC Input Voltage	-0.3 to 12	V
V _{LX}	Switch Pin Voltage	-0.3 to (V _{CC} + 0.3)	V
V _{SHDN}	Shutdown Voltage (SHDN)	-0.3 to (V _{CC} + 0.3)	V
V _S , V _C	Soft Start (SS) and Compensation Capacitor (CC) Pins Voltage	-0.3 to (V _{CC} + 0.3)	V
I _{LX}	Switching Peak Current	2	A
I _{REF}	Reference Current	2.5	mA
P _{TOT}	Continuous Power Dissipation at T _A =70°C (DIP-8) (SO-8)	550 344	mW mW
T _{stg}	Storage Temperature Range	-40 to +150	°C
T _{op}	Operating Junction Temperature Range (C series) (B series)	0 to +70 -40 to +85	°C °C

Absolute Maximum Ratings are those values beyond which damage to the device may occur. Functional operation under these condition is not implied.

THERMAL DATA

Symbol	Parameter	SO-8	DIP-8	Unit
R _{thj-amb}	Thermal Resistance Junction-ambient (*)	160	100	°C/W

(*) This value depends from thermal design of PCB on which the device is mounted.

ORDERING CODES

TYPE	DIP8	SO-8	SO-8 (T&R)
ST730AB	ST730ABN	ST730ABD	ST730ABD-TR
ST730AC	ST730ACN	ST730ACD	ST730ACD-TR

CONNECTION DIAGRAM (top view)

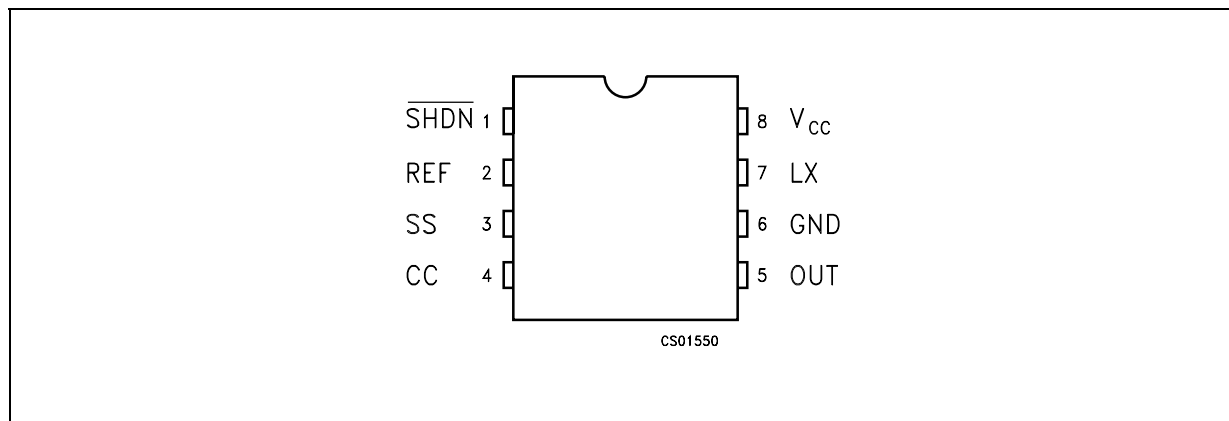

PIN DESCRIPTION

Pin N°	Symbol	Name and Function
1	SHDN	Shutdown control (active low): If connected to GND the IC is in shutdown. Connect to V _{CC} for normal operation (ON MODE)
2	REF	Reference Output Voltage: (1.25V): Bypass to GND with a capacitor that does not exceed 47nF
3	SS	Soft Start: a capacitor between SS and GND provides soft-start and short-circuit protections.
4	CC	Compensation Capacitor Input: externally compensates the outer (voltage) feedback loop. Connect to OUT with 330pF capacitor
5	OUT	Output Voltage Sense Input: provides regulation of feedback sensing. Connect to 5V output.
6	GND	Ground
7	LX	Switch Output. Drain of internal P-Channel Power MOSFET
8	V _{CC}	Supply Voltage Input. Bypass to GND with 1μF ceramic capacitance and large value electrolytic capacitor in parallel. The 1μF capacitor must be as close as possible to the GND and V _{CC} pins

ST730A

ELECTRICAL CHARACTERISTICS ($V_{CC}=5V$, $I_O=0mA$, $T_A=T_{MIN}$ to T_{MAX} , unless otherwise specified.)

Symbol	Parameter	Test Conditions	Min.	Typ.	Max.	Unit
V_{CC}	Input Voltage		4		11	V
V_O	Output Voltage	$V_{CC} = 6$ to $11V$ $I_O = 0$ to $450mA$	4.75	5	5.25	V
ΔV_O	Line Regulation	$V_{CC} = 5.2$ to $11V$		0.15		%/V
ΔV_O	Load Regulation	$I_O = 0$ to $450mA$		0.005		%/mA
η	Power Efficiency	$I_O = 300mA$		92		%
I_{SUPPLY}	Supply Current	ON Mode _____ OFF Mode, SHDN=0		0.8 0.3	2.5 100	mA μA
V_{IH}	SHDN Input High Threshold		2			V
V_{IL}	SHDN Input Low Threshold				0.25	V
I_{SHDN}	Shutdown Input Leakage Current				1	μA
V_{LOCK}	Under Voltage Lockout	V_{CC} Falling		2.7	3	V
$R_{DS(on)}$	LX On Resistance	$I_{LX}=500mA$		0.5		Ω
I_{LX}	LX Leakage Current	$V_{CC} = 12V$ $V_{LX} = 0V$		1		μA
V_{REF}	Reference Voltage	$T_A = 25^\circ C$	1.17	1.24	1.31	V
ΔV_{REF}	Temperature Reference Drift			50		ppm/ $^\circ C$
f_{OSC}	Switching Frequency	B series C series	180 160	200	220 280	KHz
R_C	Compensation Pin Impedance			7500		Ω

TYPICAL APPLICATION CIRCUIT

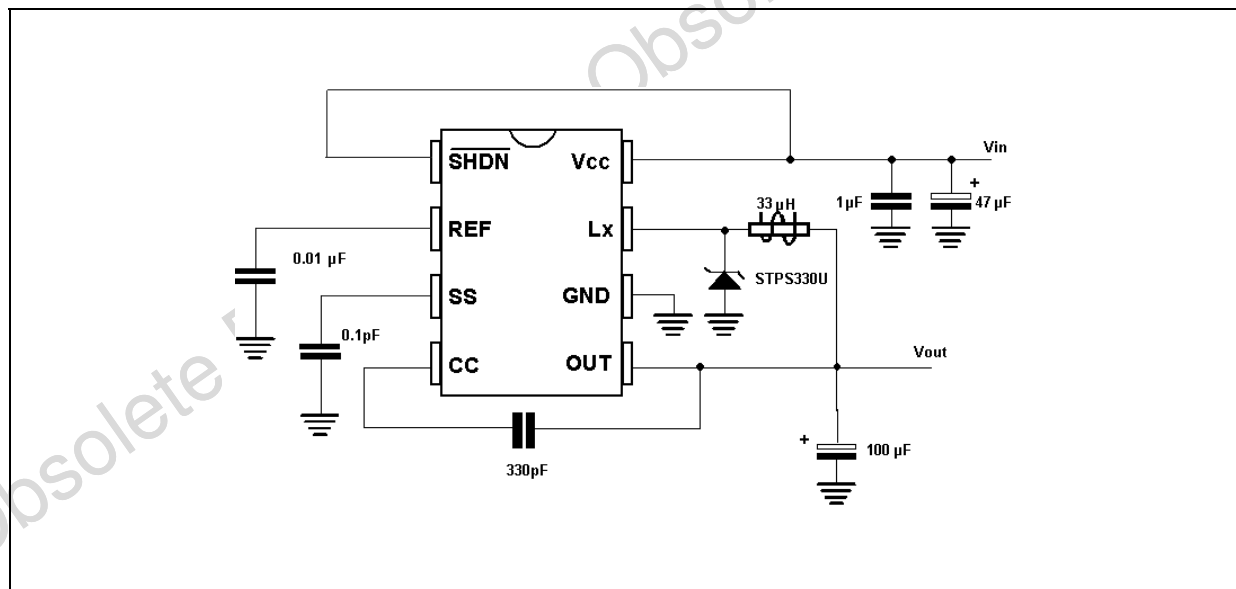

TYPICAL PERFORMANCE CHARACTERISTICS (unless otherwise specified $T_j = 25^\circ\text{C}$)

Figure 1 : Efficiency vs Output Current

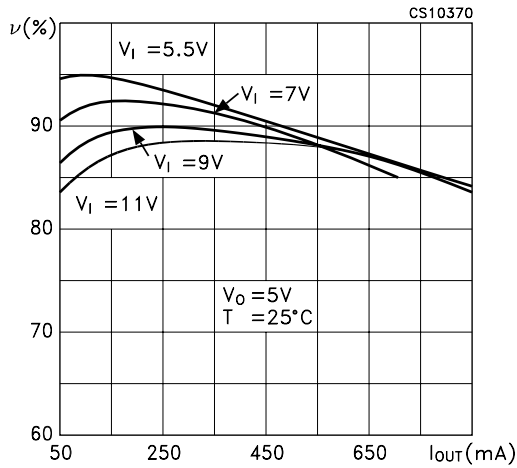

Figure 2 : Supply Current vs Temperature

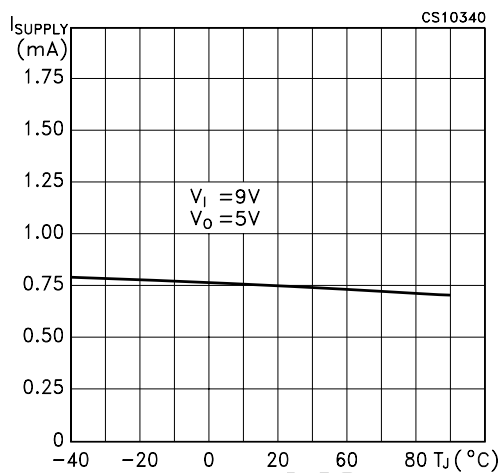

Figure 3 : Oscillator Frequency vs Temperature

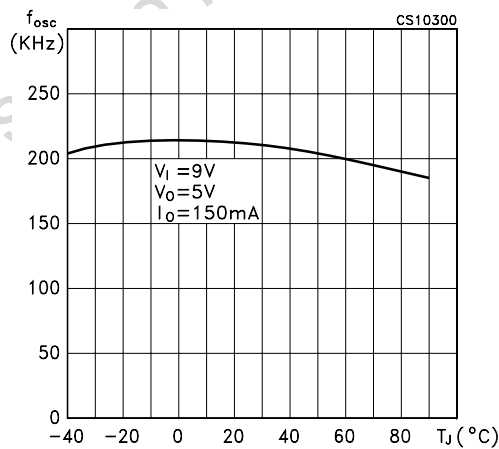

Figure 4 : Oscillator Frequency vs Input Voltage

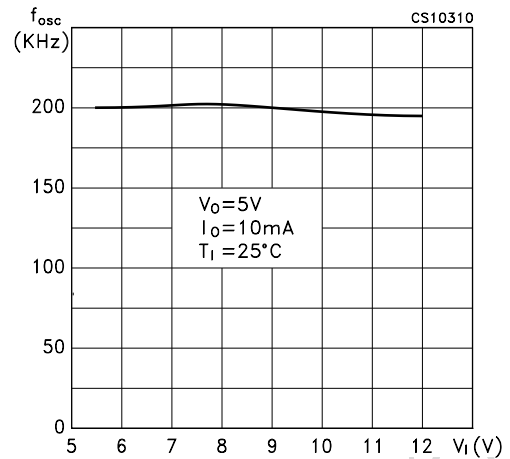

Figure 5 : Peak Inductor Current vs Output Current

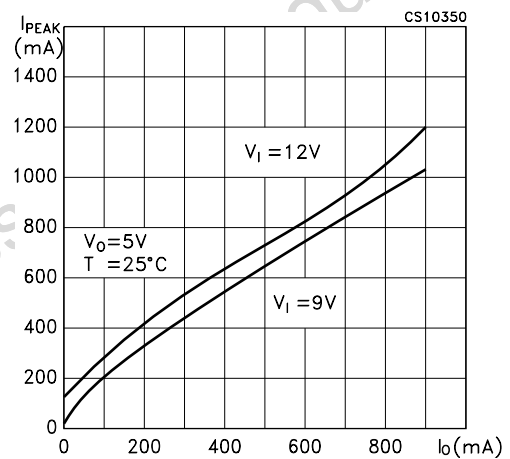

Figure 6 : Output Voltage vs Output Current

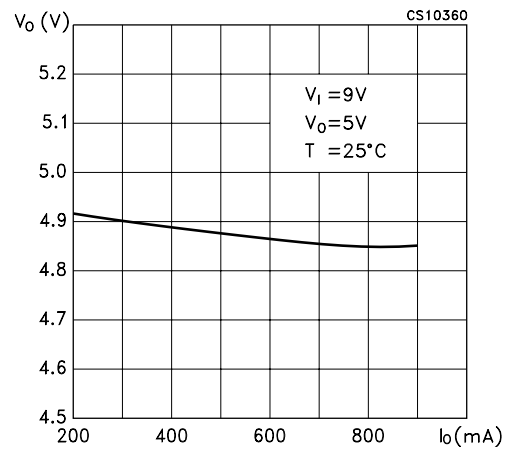

Figure 7 : Switching Waveforms, Continuous Conduction

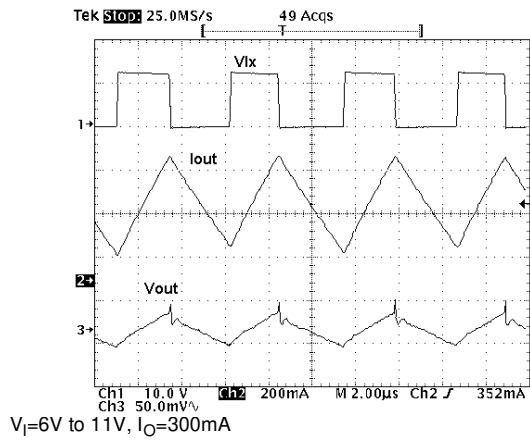

Figure 9 : Line Transient

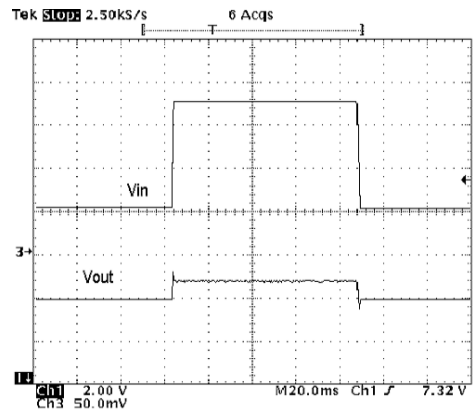

Figure 8 : Switching Waveforms, Discontinuous Conduction

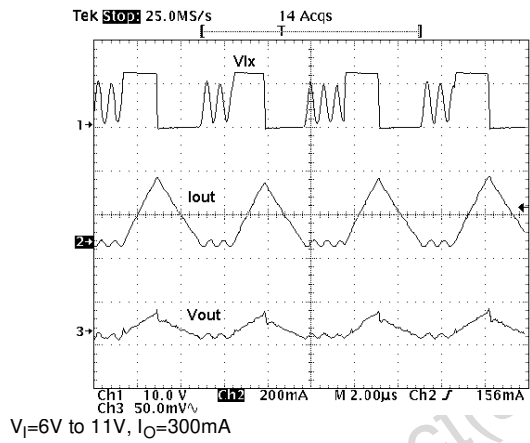
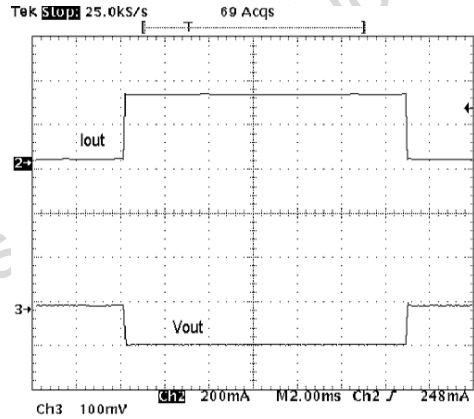

Figure 10 : Load Transient



Obsolete Product(s) - Obsolete Product(s)

Plastic DIP-8 MECHANICAL DATA						
--------------------------------------	--	--	--	--	--	--

DIM.	mm.			inch		
	MIN.	TYP.	MAX.	MIN.	TYP.	MAX.
A		3.3			0.130	
a1	0.7			0.028		
B	1.39		1.65	0.055		0.065
B1	0.91		1.04	0.036		0.041
b		0.5			0.020	
b1	0.38		0.5	0.015		0.020
D			9.8			0.386
E		8.8			0.346	
e		2.54			0.100	
e3		7.62			0.300	
e4		7.62			0.300	
F			7.1			0.280
I			4.8			0.189
L		3.3			0.130	
Z	0.44		1.6	0.017		0.063

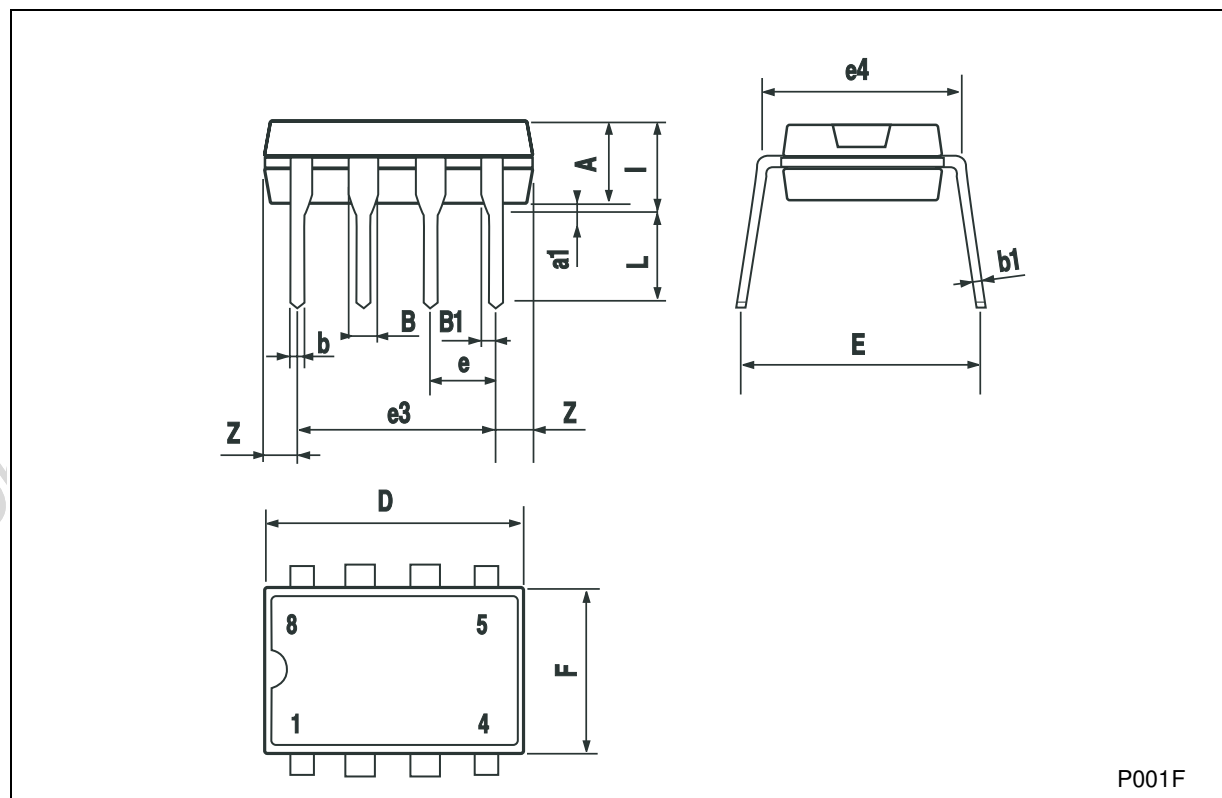

P001F

SO-8 MECHANICAL DATA

DIM.	mm.			inch		
	MIN.	TYP.	MAX.	MIN.	TYP.	MAX.
A	1.35		1.75	0.053		0.069
A1	0.10		0.25	0.04		0.010
A2	1.10		1.65	0.043		0.065
B	0.33		0.51	0.013		0.020
C	0.19		0.25	0.007		0.010
D	4.80		5.00	0.189		0.197
E	3.80		4.00	0.150		0.157
e		1.27			0.050	
H	5.80		6.20	0.228		0.244
h	0.25		0.50	0.010		0.020
L	0.40		1.27	0.016		0.050
k	8° (max.)					
ddd			0.1			0.04

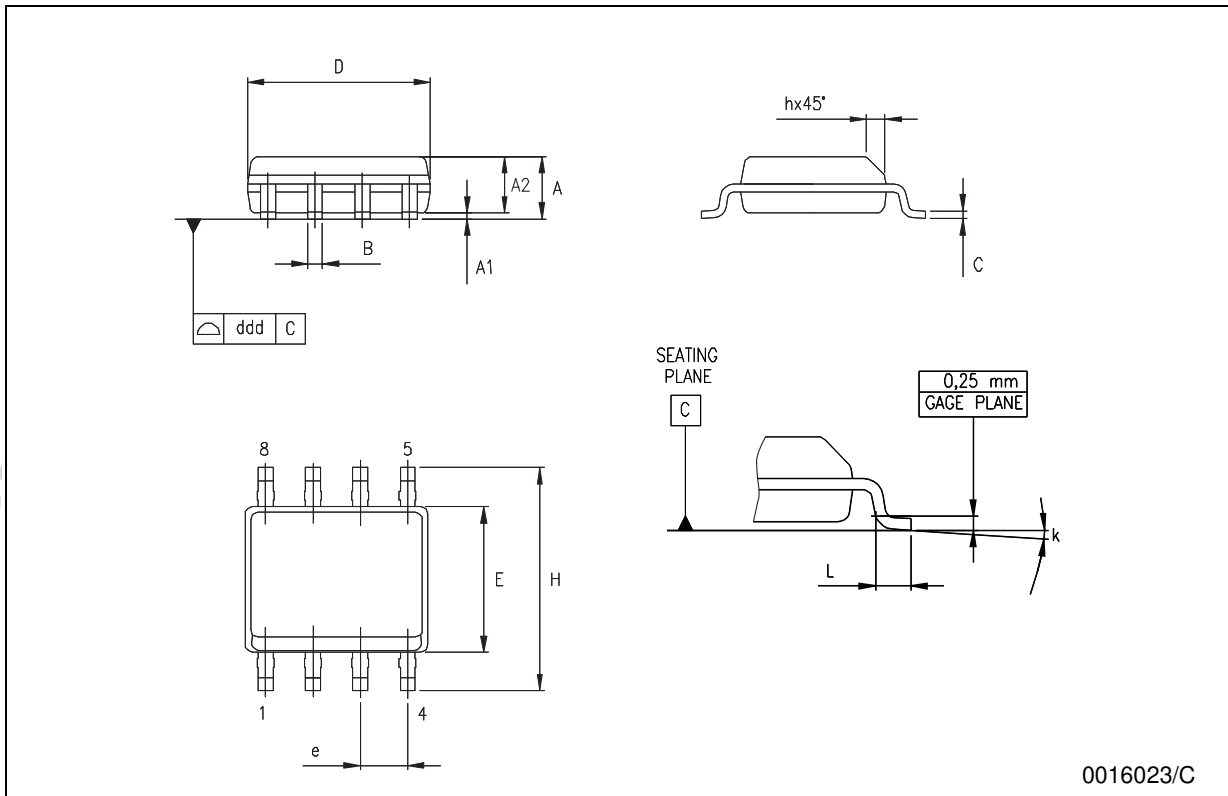

0016023/C

Information furnished is believed to be accurate and reliable. However, STMicroelectronics assumes no responsibility for the consequences of use of such information nor for any infringement of patents or other rights of third parties which may result from use. No license is granted by implication or otherwise under any patent or patent rights of STMicroelectronics. Specifications mentioned in this publication are subject to change without notice. This publication supersedes and replaces all information previously supplied. STMicroelectronics products are not authorized for use as critical components in life support devices or systems without express written approval of STMicroelectronics.

© The ST logo is a registered trademark of STMicroelectronics

© 2003 STMicroelectronics - Printed in Italy - All Rights Reserved
STMicroelectronics GROUP OF COMPANIES

Australia - Brazil - Canada - China - Finland - France - Germany - Hong Kong - India - Israel - Italy - Japan - Malaysia - Malta - Morocco
Singapore - Spain - Sweden - Switzerland - United Kingdom - United States.

© <http://www.st.com>