



Chipsmall Limited consists of a professional team with an average of over 10 year of expertise in the distribution of electronic components. Based in Hongkong, we have already established firm and mutual-benefit business relationships with customers from,Europe,America and south Asia,supplying obsolete and hard-to-find components to meet their specific needs.

With the principle of "Quality Parts,Customers Priority,Honest Operation,and Considerate Service",our business mainly focus on the distribution of electronic components. Line cards we deal with include Microchip,ALPS,ROHM,Xilinx,Pulse,ON,Everlight and Freescale. Main products comprise IC,Modules,Potentiometer,IC Socket,Relay,Connector.Our parts cover such applications as commercial,industrial, and automotives areas.

We are looking forward to setting up business relationship with you and hope to provide you with the best service and solution. Let us make a better world for our industry!



## Contact us

Tel: +86-755-8981 8866 Fax: +86-755-8427 6832

Email & Skype: info@chipsmall.com Web: www.chipsmall.com

Address: A1208, Overseas Decoration Building, #122 Zhenhua RD., Futian, Shenzhen, China



## High voltage NPN Darlington transistor for ignition coil

### Features

- High voltage special Darlington structure
- Very rugged bipolar technology
- High DC current gain

### Application

- High ruggedness electronic ignition for small engines

### Description

The device is a high voltage NPN transistor in monolithic special Darlington configuration designed for applications such as electronic ignition for small engines (scooters, lawnmowers, chainsaws).

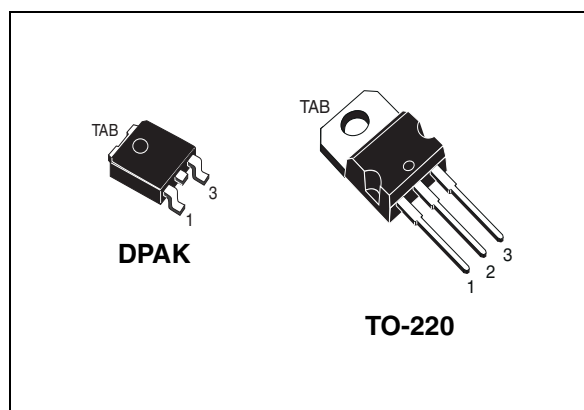

**Figure 1. Internal schematic diagram**

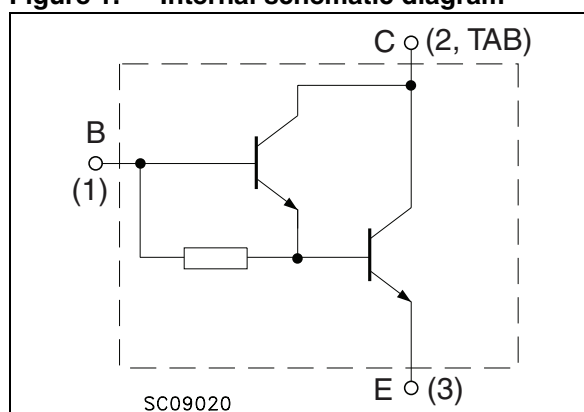

**Table 1. Device summary**

Order code	Marking	Packages	Packaging
ST901T	901T	TO-220	Tube
STD901T	D901T	DPAK	Tape and reel

# Contents

<b>1</b>	<b>Electrical ratings</b> .....	<b>3</b>
<b>2</b>	<b>Electrical characteristics</b> .....	<b>4</b>
2.1	Electrical characteristics (curves) .....	5
<b>3</b>	<b>Package mechanical data</b> .....	<b>6</b>
<b>4</b>	<b>Revision history</b> .....	<b>11</b>

# 1 Electrical ratings

**Table 2. Absolute maximum ratings**

Symbol	Parameter	Value	Unit
$V_{CES}$	Collector-emitter voltage ( $V_{BE} = 0$ )	500	V
$V_{CEO}$	Collector-emitter voltage ( $I_B = 0$ )	350	V
$V_{EBO}$	Emitter-base voltage ( $I_C = 0$ )	5	V
$I_C$	Collector current	4	A
$I_{CM}$	Collector peak current ( $t_p < 5$ ms)	8	A
$I_B$	Base current	0.5	A
$I_{BM}$	Base peak current ( $t_p < 5$ ms)	2.5	A
$P_{tot}$	Total dissipation at $T_C = 25$ °C for ST901T	100	W
$P_{tot}$	Total dissipation at $T_C = 25$ °C for STD901T	35	W
$T_{stg}$	Storage temperature	-65 to 150	°C
$T_J$	Max. operating junction temperature	150	°C

**Table 3. Thermal data**

Symbol	Parameter	Value	Unit
$R_{thj-case}$	Thermal resistance junction-case max for ST901T	1.25	°C/W
$R_{thj-case}$	Thermal resistance junction-case max for STD901T	3.57	°C/W

## 2 Electrical characteristics

( $T_{\text{case}} = 25^{\circ}\text{C}$  unless otherwise specified).

**Table 4. Electrical characteristics**

Symbol	Parameter	Test conditions	Min.	Typ.	Max.	Unit
$I_{\text{CES}}$	Collector cut-off current ( $I_{\text{E}} = 0$ )	$V_{\text{CE}} = 500 \text{ V}$			100	$\mu\text{A}$
		$V_{\text{CE}} = 500 \text{ V } T_{\text{case}} = 125^{\circ}\text{C}$			500	$\mu\text{A}$
$I_{\text{CEO}}$	Collector cut-off current ( $I_{\text{B}} = 0$ )	$V_{\text{CE}} = 350 \text{ V}$			100	$\mu\text{A}$
		$V_{\text{CE}} = 350 \text{ V } T_{\text{case}} = 125^{\circ}\text{C}$			500	$\mu\text{A}$
$I_{\text{EBO}}$	Emitter cut-off current ( $I_{\text{C}} = 0$ )	$V_{\text{EB}} = 5 \text{ V}$			10	$\mu\text{A}$
$V_{\text{CEO(sus)}}^{(1)}$	Collector-emitter sustaining voltage ( $I_{\text{B}} = 0$ )	$I_{\text{C}} = 10 \text{ mA}$	350			V
$V_{\text{CE(sat)}}^{(1)}$	Collector-emitter saturation voltage	$I_{\text{C}} = 2 \text{ A}$ $I_{\text{B}} = 20 \text{ mA}$			2	V
$V_{\text{BE(sat)}}^{(1)}$	Base-emitter saturation voltage	$I_{\text{C}} = 2 \text{ A}$ $I_{\text{B}} = 20 \text{ mA}$			1.8	V
$h_{\text{FE}}$	DC current gain	$I_{\text{C}} = 2 \text{ A}$ $V_{\text{CE}} = 2 \text{ V}$	1800		3800	
		$I_{\text{C}} = 4 \text{ A}$ $V_{\text{CE}} = 2 \text{ V}$	500			
	Functional test	$V_{\text{CC}} = 24 \text{ V}$ $V_{\text{clamp}} = 350 \text{ V}$ $L = 4 \text{ mH}$	4			A
$t_{\text{s}}$ $t_{\text{f}}$	Inductive load storage time	$V_{\text{CC}} = 12 \text{ V}$ $L = 4 \text{ mH}$ $I_{\text{C}} = 2 \text{ A}$ $V_{\text{clamp}} = 250 \text{ V}$		15		$\mu\text{s}$
	fall time	$I_{\text{B(on)}} = 20 \text{ mA}$ $V_{\text{BE(off)}} = -3 \text{ V}$		1.5		$\mu\text{s}$

1. Pulse test: pulse duration  $\leq 300 \mu\text{s}$ , duty cycle  $\leq 2\%$

## 2.1 Electrical characteristics (curves)

**Figure 2. Collector-emitter saturation voltage ( $h_{FE} = 100$ )**

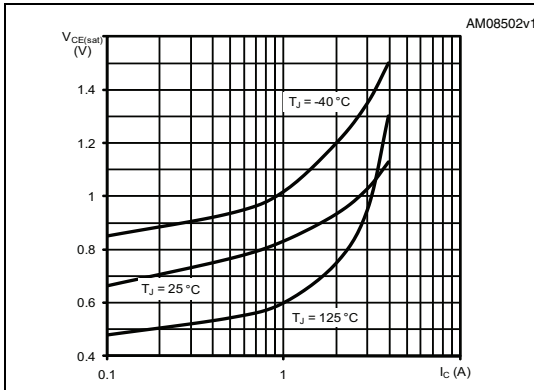

**Figure 3. Base-emitter saturation voltage ( $h_{FE} = 100$ )**

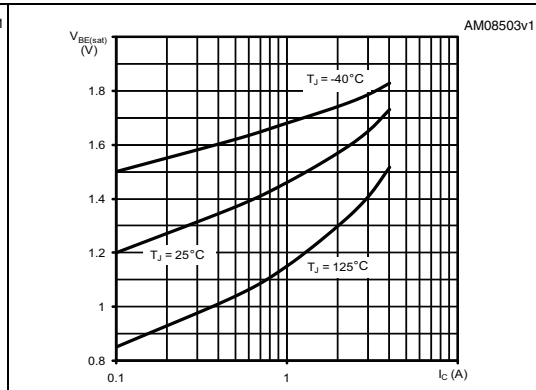

**Figure 4. DC current gain ( $V_{CE} = 2\text{ V}$ )**

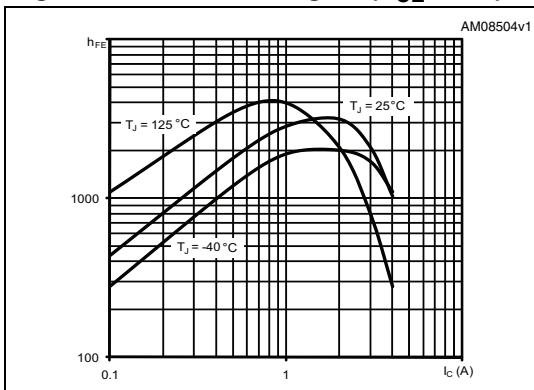

**Figure 5. DC current gain ( $V_{CE} = 5\text{ V}$ )**

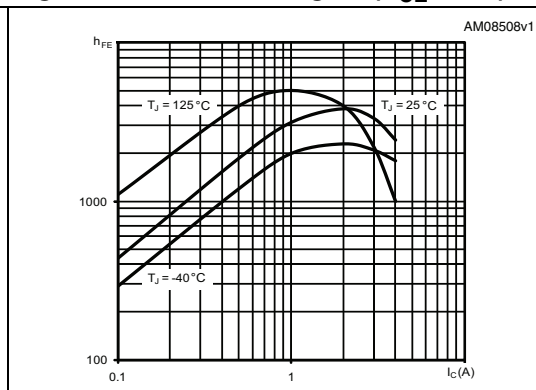

### 3 Package mechanical data

In order to meet environmental requirements, ST offers these devices in different grades of ECOPACK® packages, depending on their level of environmental compliance. ECOPACK® specifications, grade definitions and product status are available at: [www.st.com](http://www.st.com). ECOPACK is an ST trademark.

Table 5. TO-220 type A mechanical data

Dim.	mm		
	Min.	Typ.	Max.
A	4.40		4.60
b	0.61		0.88
b1	1.14		1.70
c	0.48		0.70
D	15.25		15.75
D1		1.27	
E	10		10.40
e	2.40		2.70
e1	4.95		5.15
F	1.23		1.32
H1	6.20		6.60
J1	2.40		2.72
L	13		14
L1	3.50		3.93
L20		16.40	
L30		28.90	
∅P	3.75		3.85
Q	2.65		2.95

Figure 6. TO-220 type A drawing

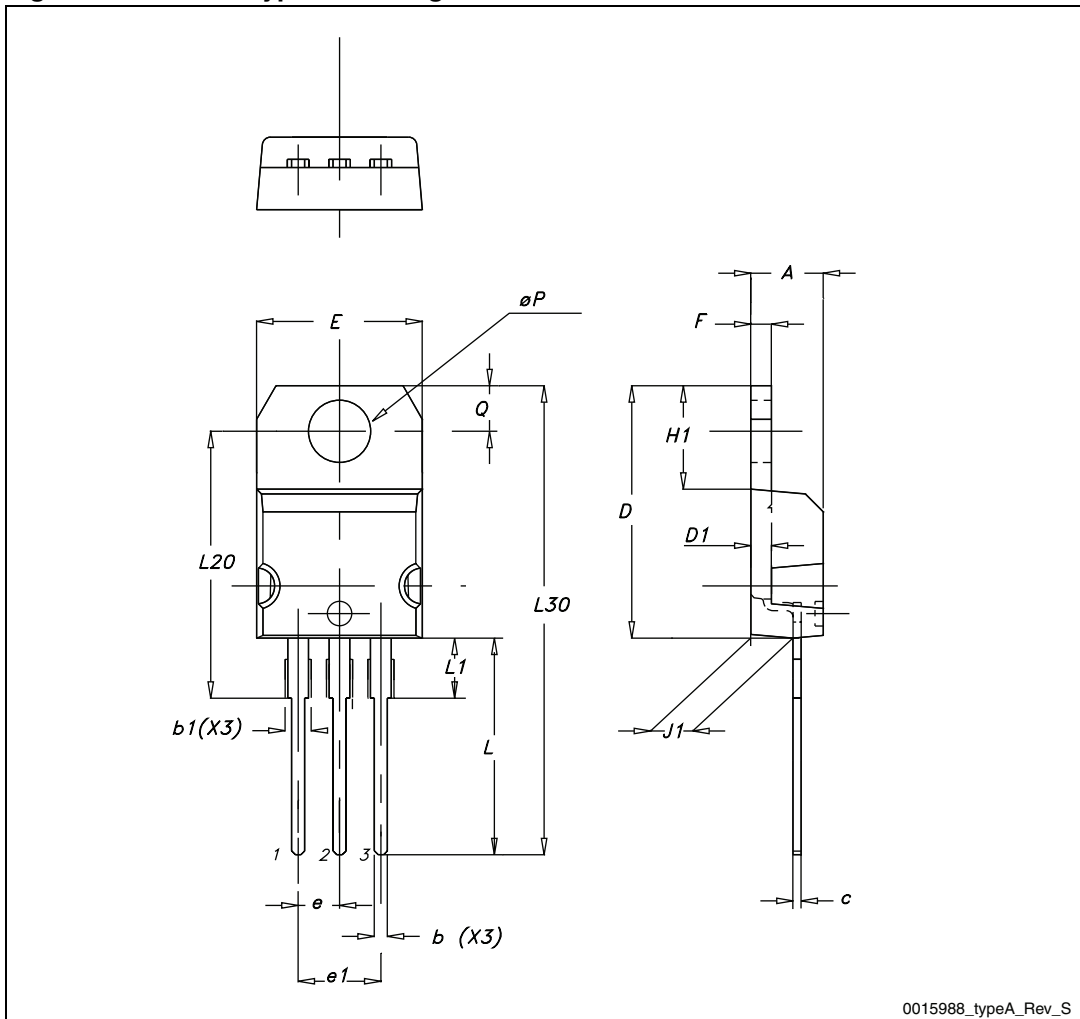

0015988\_typeA\_Rev\_S

Table 6. DPAK (TO-252) mechanical data

Dim.	mm		
	Min.	Typ.	Max.
A	2.20		2.40
A1	0.90		1.10
A2	0.03		0.23
b	0.64		0.90
b4	5.20		5.40
c	0.45		0.60
c2	0.48		0.60
D	6.00		6.20
D1		5.10	
E	6.40		6.60
E1		4.70	
e		2.28	
e1	4.40		4.60
H	9.35		10.10
L	1		
L1		2.80	
L2		0.80	
L4	0.60		1
R		0.20	
V2	0°		8°

Figure 7. TO-252 (DPAK) drawings

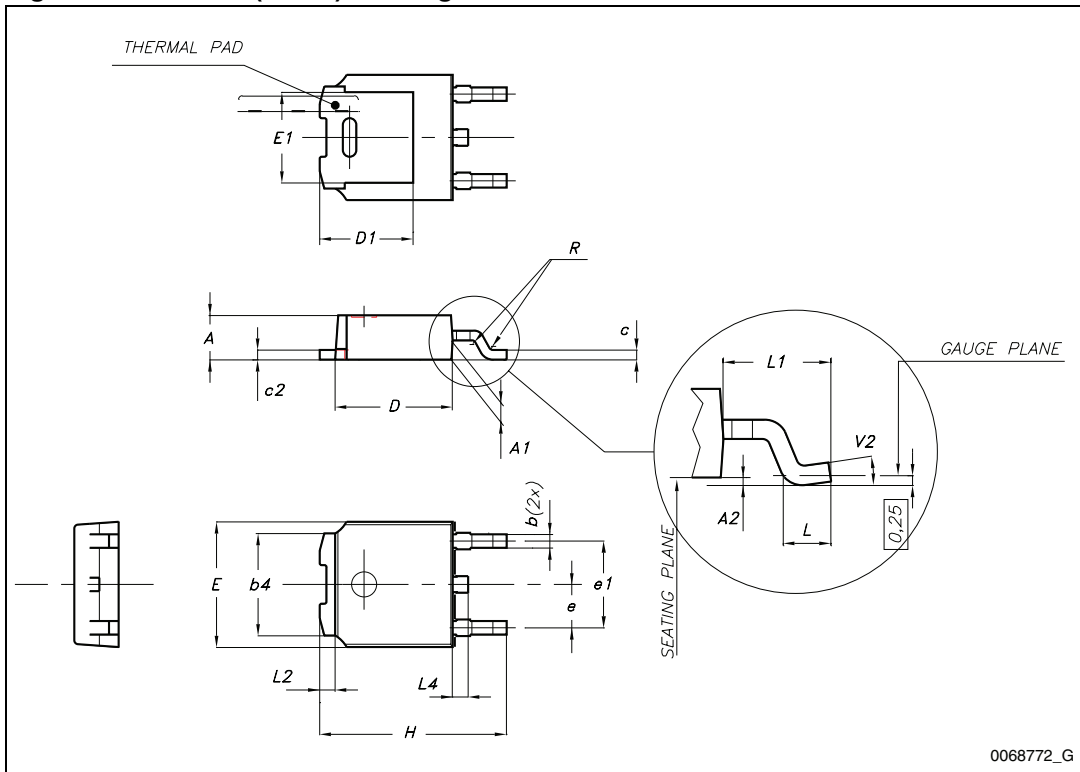

## 4 Revision history

**Table 7. Document revision history**

<b>Date</b>	<b>Revision</b>	<b>Changes</b>
14-Oct-2004	1	First release.
15-Jan-2005	2	DC current gain range has been modified.
25-Feb-2005	3	Added four drawings on page 3.
13-Oct-2005	4	Updated package mechanical data
11-Feb-2011	5	Inserted new order code STD901T

**Please Read Carefully:**

Information in this document is provided solely in connection with ST products. STMicroelectronics NV and its subsidiaries ("ST") reserve the right to make changes, corrections, modifications or improvements, to this document, and the products and services described herein at any time, without notice.

All ST products are sold pursuant to ST's terms and conditions of sale.

Purchasers are solely responsible for the choice, selection and use of the ST products and services described herein, and ST assumes no liability whatsoever relating to the choice, selection or use of the ST products and services described herein.

No license, express or implied, by estoppel or otherwise, to any intellectual property rights is granted under this document. If any part of this document refers to any third party products or services it shall not be deemed a license grant by ST for the use of such third party products or services, or any intellectual property contained therein or considered as a warranty covering the use in any manner whatsoever of such third party products or services or any intellectual property contained therein.

**UNLESS OTHERWISE SET FORTH IN ST'S TERMS AND CONDITIONS OF SALE ST DISCLAIMS ANY EXPRESS OR IMPLIED WARRANTY WITH RESPECT TO THE USE AND/OR SALE OF ST PRODUCTS INCLUDING WITHOUT LIMITATION IMPLIED WARRANTIES OF MERCHANTABILITY, FITNESS FOR A PARTICULAR PURPOSE (AND THEIR EQUIVALENTS UNDER THE LAWS OF ANY JURISDICTION), OR INFRINGEMENT OF ANY PATENT, COPYRIGHT OR OTHER INTELLECTUAL PROPERTY RIGHT.**

**UNLESS EXPRESSLY APPROVED IN WRITING BY AN AUTHORIZED ST REPRESENTATIVE, ST PRODUCTS ARE NOT RECOMMENDED, AUTHORIZED OR WARRANTED FOR USE IN MILITARY, AIR CRAFT, SPACE, LIFE SAVING, OR LIFE SUSTAINING APPLICATIONS, NOR IN PRODUCTS OR SYSTEMS WHERE FAILURE OR MALFUNCTION MAY RESULT IN PERSONAL INJURY, DEATH, OR SEVERE PROPERTY OR ENVIRONMENTAL DAMAGE. ST PRODUCTS WHICH ARE NOT SPECIFIED AS "AUTOMOTIVE GRADE" MAY ONLY BE USED IN AUTOMOTIVE APPLICATIONS AT USER'S OWN RISK.**

Resale of ST products with provisions different from the statements and/or technical features set forth in this document shall immediately void any warranty granted by ST for the ST product or service described herein and shall not create or extend in any manner whatsoever, any liability of ST.

ST and the ST logo are trademarks or registered trademarks of ST in various countries.

Information in this document supersedes and replaces all information previously supplied.

The ST logo is a registered trademark of STMicroelectronics. All other names are the property of their respective owners.

© 2011 STMicroelectronics - All rights reserved

STMicroelectronics group of companies

Australia - Belgium - Brazil - Canada - China - Czech Republic - Finland - France - Germany - Hong Kong - India - Israel - Italy - Japan - Malaysia - Malta - Morocco - Philippines - Singapore - Spain - Sweden - Switzerland - United Kingdom - United States of America

[www.st.com](http://www.st.com)