



Chipsmall Limited consists of a professional team with an average of over 10 year of expertise in the distribution of electronic components. Based in Hongkong, we have already established firm and mutual-benefit business relationships with customers from,Europe,America and south Asia,supplying obsolete and hard-to-find components to meet their specific needs.

With the principle of “Quality Parts,Customers Priority,Honest Operation,and Considerate Service”,our business mainly focus on the distribution of electronic components. Line cards we deal with include Microchip,ALPS,ROHM,Xilinx,Pulse,ON,Everlight and Freescale. Main products comprise IC,Modules,Potentiometer,IC Socket,Relay,Connector.Our parts cover such applications as commercial,industrial, and automotives areas.

We are looking forward to setting up business relationship with you and hope to provide you with the best service and solution. Let us make a better world for our industry!



## Contact us

Tel: +86-755-8981 8866 Fax: +86-755-8427 6832

Email & Skype: info@chipsmall.com Web: www.chipsmall.com

Address: A1208, Overseas Decoration Building, #122 Zhenhua RD., Futian, Shenzhen, China





# ST92F124xx/ST92F150Cxx/ ST92F150JDV1/ST92F250CV2

8/16-bit single voltage Flash MCU family with RAM,  
E<sup>3</sup>™ (emulated EEPROM), CAN 2.0B and J1850 BLPD

Datasheet – production data

## Features

- Memories
    - Internal memory: Single Voltage Flash up to 256 Kbytes, RAM up to 8 Kbytes, 1 Kbyte E<sup>3</sup>™ (Emulated EEPROM)
    - In-Application Programming (IAP)
    - 224 general purpose registers (register file) available as RAM, accumulators or index pointers
  - Clock, reset and supply management
    - Register-oriented 8/16 bit CORE with RUN, WFI, SLOW, HALT and STOP modes
    - 0-24 MHz Operation (Int. Clock), 4.5-5.5 V range
    - PLL Clock Generator (3-5 MHz crystal)
    - Minimum instruction time: 83 ns (24 MHz int. clock)
  - Up to 80 I/O pins
  - Interrupt management
    - 4 external fast interrupts + 1 NMI
    - Up to 16 pins programmable as wake-up or additional external interrupt with multi-level interrupt handler
  - DMA controller for reduced processor overhead
  - Timers
    - 16-bit Timer with 8-bit Prescaler, and Watchdog Timer (activated by software or by hardware)
    - 16-bit Standard Timer that can be used to generate a time base independent of PLL Clock Generator
    - Two 16-bit independent Extended Function Timers (EFTs) with Prescaler, up to two Input Captures and up to two Output Compares
    - Two 16-bit Multifunction Timers, with Prescaler, up to two Input Captures and up to two Output Compares
  - Communication interfaces
    - Serial Peripheral Interface (SPI) with selectable Master/Slave mode
- One Multiprotocol Serial Communications Interface with asynchronous and synchronous capabilities
  - One asynchronous Serial Communications Interface with 13-bit LIN Synch Break generation capability
  - J1850 Byte Level Protocol Decoder (JBLPD)
  - Up to two full I<sup>2</sup>C multiple Master/Slave Interfaces supporting Access Bus
  - Up to two CAN 2.0B Active interfaces
- Analog peripheral (low current coupling)
  - 10-bit A/D Converter with up to 16 robust input channels
- Development tools
  - Free High performance development environment (IDE) based on Visual Debugger, Assembler, Linker, and C-Compiler; Real Time Operating System (OSEK OS, CMX) and CAN drivers
  - Hardware emulator and Flash programming board for development and ISP Flasher for production

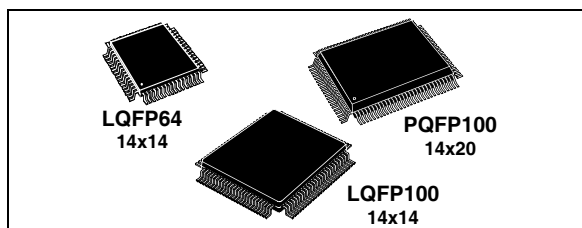

Table 1. Device summary

Reference	Part number
ST92F124xx	ST92F124R1, ST92F124R9, ST92F124V1
ST92F150Cxx	ST92F150CR1, ST92F150CR9, ST92F150CV1, ST92F150CV9
ST92F150JDxx	ST92F150JDV1
ST92F250Cxx	ST92F250CV2

# Contents

<b>1</b>	<b>Description</b> .....	<b>20</b>
<b>2</b>	<b>Pinout and pin description</b> .....	<b>27</b>
2.1	I/O port alternate functions .....	28
2.2	Termination of unused pins .....	28
<b>3</b>	<b>Voltage regulator</b> .....	<b>40</b>
<b>4</b>	<b>I/O ports</b> .....	<b>41</b>
4.1	Alternate functions for I/O ports .....	43
<b>5</b>	<b>Operating modes</b> .....	<b>48</b>
<b>6</b>	<b>Device architecture</b> .....	<b>49</b>
6.1	Core architecture .....	49
6.2	Memory spaces .....	49
6.2.1	Register file .....	49
6.2.2	Register addressing .....	51
6.3	System registers .....	53
6.3.1	Central interrupt control register .....	54
6.3.2	Flag register .....	55
6.3.3	Register pointing techniques .....	57
6.3.4	Paged registers .....	60
6.3.5	Mode register .....	61
6.3.6	Stack pointers .....	62
6.4	Memory organization .....	65
6.5	Memory management unit .....	66
6.6	Address space extension .....	66
6.6.1	Addressing 16-Kbyte pages .....	66
6.6.2	Addressing 64-Kbyte segments .....	67
6.7	MMU registers .....	68
6.7.1	DPR[3:0]: data page registers .....	68
6.7.2	CSR: Code segment register .....	70
6.7.3	ISR: Interrupt segment register .....	70

6.7.4	DMASR: DMA segment register	71
6.8	MMU usage	72
6.8.1	Normal program execution	72
6.8.2	Interrupts	73
6.8.3	DMA	74
<b>7</b>	<b>Single voltage Flash and E3™ (emulated EEPROM)</b>	<b>75</b>
7.1	Introduction	75
7.2	Functional description	76
7.2.1	Structure	76
7.2.2	EEPROM emulation	76
7.2.3	Operation	78
7.2.4	E3™ update operation	78
7.2.5	Important note on Flash erase suspend	79
7.3	Register description	80
7.3.1	Control registers	80
7.3.2	Status registers	84
7.4	Write operation example	86
7.5	Protection strategy	87
7.5.1	Non volatile registers	87
7.5.2	Temporary unprotection	90
7.6	Flash in-system programming	92
7.6.1	Code update routine	92
<b>8</b>	<b>Register and memory map</b>	<b>95</b>
8.1	Introduction	95
8.2	Memory configuration	95
8.2.1	Reset vector location	95
8.2.2	Location of vector for external watchdog refresh	95
8.3	ST92F124/F150/F250 register map	101
<b>9</b>	<b>Interrupts</b>	<b>121</b>
9.1	Introduction	121
9.1.1	On-chip peripheral interrupt sources	121
9.2	Interrupt vectoring	122
9.2.1	Divide by zero trap	123

9.2.2	Segment paging during interrupt routines	123
9.3	Interrupt priority levels	124
9.4	Priority level arbitration	124
9.4.1	Priority level 7 (Lowest)	124
9.4.2	Maximum depth of nesting	124
9.4.3	Simultaneous interrupts	125
9.4.4	Dynamic priority level modification	125
9.5	Arbitration modes	126
9.5.1	Concurrent mode	126
9.5.2	Nested mode	129
9.6	External interrupts	131
9.7	Standard interrupts (CAN and SCI-A)	135
9.7.1	Functional description	135
9.7.2	Important note on standard interrupts	137
9.8	Top level interrupt	137
9.9	Dedicated on-chip peripheral interrupts	137
9.10	Interrupt response time	138
9.11	Interrupt registers	139
9.12	Wake-up / interrupt lines management unit (WUIMU)	149
9.12.1	Introduction	149
9.12.2	Main features	150
9.12.3	Functional description	151
9.12.4	Programming considerations	154
9.12.5	Register description	155
9.12.6	Important note on WUIMU	158
<b>10</b>	<b>On-chip direct memory access (DMA)</b>	<b>159</b>
10.1	Introduction	159
10.2	DMA priority levels	159
10.3	DMA transactions	160
10.4	DMA cycle time	162
10.5	Swap mode	162
10.6	DMA registers	163
<b>11</b>	<b>Reset and clock control unit (RCCU)</b>	<b>165</b>

11.1	Introduction	165
11.2	Clock control unit	165
11.2.1	Clock control unit overview	165
11.3	Clock management	167
11.3.1	PLL clock multiplier programming	168
11.3.2	PLL free running mode	169
11.3.3	CPU clock prescaling	169
11.3.4	Peripheral clock	170
11.3.5	Low power modes	170
11.3.6	Interrupt generation	171
11.4	Clock control registers	174
11.5	Crystal oscillator	180
11.6	Reset/stop manager	183
11.6.1	Reset pin timing	184
<b>12</b>	<b>External memory interface (EXTMI)</b>	<b>186</b>
12.1	Introduction	186
12.2	External memory signals	186
12.2.1	AS: Address strobe	187
12.2.2	DS: Data strobe	187
12.2.3	RW: Read/write	187
12.2.4	DS2: Data strobe 2	187
12.2.5	PORT 0	188
12.2.6	PORT 1	188
12.2.7	PORT 9 [7:2]	188
12.2.8	WAIT: External memory wait	190
12.3	Register description	191
<b>13</b>	<b>I/O ports</b>	<b>195</b>
13.1	Introduction	195
13.2	Specific port configurations	195
13.3	Port control registers	195
13.4	Input/output bit configuration	196
13.5	Alternate function architecture	200
13.5.1	Pin declared as I/O	200
13.5.2	Pin declared as an alternate function input	200

13.5.3 Pin declared as an alternate function output ..... 201

13.6 I/O status after Wfi, Halt and Reset ..... 201

**14 On-chip peripherals ..... 203**

14.1 Timer/watchdog (WDT) ..... 203

14.1.1 Introduction ..... 203

14.1.2 Functional description ..... 204

14.1.3 Watchdog timer operation ..... 206

14.1.4 WDT interrupts ..... 208

14.1.5 Register description ..... 209

14.2 Standard timer (STIM) ..... 213

14.2.1 Introduction ..... 213

14.2.2 Functional description ..... 214

14.2.3 Interrupt selection ..... 215

14.2.4 Register description ..... 216

14.3 Extended function timer (EFT) ..... 217

14.3.1 Introduction ..... 217

14.3.2 Main features ..... 218

14.3.3 Functional description ..... 218

14.3.4 Interrupt management ..... 231

14.3.5 Register description ..... 233

14.4 Multifunction timer (MFT) ..... 241

14.4.1 Introduction ..... 241

14.4.2 Functional description ..... 243

14.4.3 Input pin assignment ..... 247

14.4.4 Output pin assignment ..... 252

14.4.5 Interrupt and DMA ..... 254

14.4.6 Register description ..... 258

14.5 Multiprotocol serial communications interface (SCI-M) ..... 273

14.5.1 Introduction ..... 273

14.5.2 Main features ..... 273

14.5.3 Functional description ..... 274

14.5.4 SCI-M operating modes ..... 275

14.5.5 Serial frame format ..... 277

14.5.6 Clocks and serial transmission rates ..... 280

14.5.7 SCI -M initialization procedure ..... 281

14.5.8	Input signals	283
14.5.9	Output signals	283
14.5.10	Interrupts and DMA	284
14.5.11	Register description	287
14.6	Asynchronous serial communications interface (SCI-A)	300
14.6.1	Introduction	300
14.6.2	Main features	301
14.6.3	General description	301
14.6.4	Functional description	303
14.6.5	Register description	309
14.6.6	Important notes on SCI-A	317
14.7	Serial peripheral interface (SPI)	317
14.7.1	Introduction	317
14.7.2	Main features	317
14.7.3	General description	317
14.7.4	Functional description	319
14.7.5	Interrupt management	326
14.7.6	Register description	327
14.8	I2C bus interface	331
14.8.1	Introduction	331
14.8.2	Main features	331
14.8.3	Functional description	333
14.8.4	I2C state machine	335
14.8.5	Interrupt features	340
14.8.6	DMA features	342
14.8.7	Register description	344
14.8.8	Important notes on I2C	359
14.9	J1850 byte level protocol decoder (JBLPD)	359
14.9.1	Introduction	359
14.9.2	Main features	360
14.9.3	Functional description	361
14.9.4	Peripheral functional modes	373
14.9.5	Interrupt features	374
14.9.6	DMA features	376
14.9.7	Register description	380
14.10	Controller area network (bxCAN)	406

14.10.1	Introduction	406
14.10.2	Main features	406
14.10.3	General description	407
14.10.4	Operating modes	409
14.10.5	Functional description	412
14.10.6	Interrupts	424
14.10.7	Register access protection	426
14.10.8	Register description	426
14.10.9	Important notes on CAN	451
14.11	10-bit analog to digital converter (ADC)	451
14.11.1	Main characteristics	451
14.11.2	Introduction	451
14.11.3	Functional description	453
14.11.4	Interrupts	455
14.11.5	Register description	456
<b>15</b>	<b>Electrical characteristics</b>	<b>471</b>
15.1	DC electrical characteristics	472
15.2	AC electrical characteristics	474
15.3	Flash / E3 TM specifications	476
15.4	EMC characteristics	477
15.5	RCCU characteristics	481
15.6	PLL characteristics	482
15.7	Oscillator characteristics	482
15.8	External bus timing	483
15.9	Watchdog timing	484
15.10	Standard timer timing	485
15.11	Extended function timer external timing	486
15.12	Multifunction timer external timing	487
15.13	SCI timing	488
15.14	SPI timing	489
15.15	I2C/DDC-bus timing	491
15.16	J1850 byte level protocol decoder timing	493
15.17	10-bit ADC characteristics	494

<b>16</b>	<b>General information</b>	<b>497</b>
16.1	Ordering information	497
16.2	Version-specific sales conditions	497
16.3	Package mechanical data	499
16.4	Soldering and glueability information	500
16.5	Development tools	500
16.5.1	Socket and emulator adapter information	501
<b>17</b>	<b>Known limitations</b>	<b>502</b>
17.1	FLASH erase suspend limitations	502
17.1.1	Description	502
17.1.2	Workaround	503
17.2	Flash corruption when exiting stop mode	503
17.3	I2C limitations	504
17.3.1	Start condition ignored in multimaster mode	505
17.3.2	Missing BUS error in master transmitter mode	505
17.3.3	AF bit (acknowledge failure flag) in transmitter mode (slave and master)	505
17.3.4	BUSY flag in multimaster mode	506
17.3.5	ARLO (arbitration lost) flag in multimaster mode	506
17.3.6	BUSY flag gets cleared when BUS error occurs	506
17.4	SCI-A and CAN interrupts	506
17.5	SCI-A mute mode	507
17.5.1	Mute mode description	507
17.5.2	Limitation description	507
17.5.3	Workaround	508
17.6	CAN FIFO corruption when 2 FIFO messages are pending	508
17.7	MFT DMA mask bit reset when MFT0 DMA priority level is set to 0	513
17.8	Emulation chip limitations	516
17.8.1	Reset behavior for bi-directional, weak pull-up ports	516
17.8.2	High drive I/Os when BSZ=1	517
17.8.3	ADC parasitic diode	517
17.8.4	ADC accuracy vs. negative injection current	518
17.8.5	I2CECCR register limitation	519
17.8.6	I2C behavior disturbed during DMA transactions	519
17.8.7	MFT DMA mask bit reset	519

17.8.8	DMA data corrupted by MFT input capture .....	519
17.8.9	SCI-A wrong break duration .....	520
17.8.10	LIN master mode not available on SCI-A .....	521
17.8.11	Limitations on LQFP64 devices .....	521
<b>18</b>	<b>Revision history .....</b>	<b>522</b>

## List of tables

Table 1.	Device summary . . . . .	1
Table 2.	Detailed device summary . . . . .	19
Table 3.	ST92F124/F150/F250 power supply pins . . . . .	38
Table 4.	ST92F124/F150/F250 primary function pins . . . . .	39
Table 5.	I/O port characteristics . . . . .	41
Table 6.	I/O port alternate functions . . . . .	43
Table 7.	Register file organization . . . . .	52
Table 8.	System registers (group E) . . . . .	53
Table 9.	Memory structure for 64K Flash device . . . . .	77
Table 10.	Memory structure for 128K Flash device . . . . .	77
Table 11.	Memory structure for 256K Flash device . . . . .	77
Table 12.	Sector status bits . . . . .	84
Table 13.	Flash write operations . . . . .	86
Table 14.	E3 TM Write operations . . . . .	86
Table 15.	SCIO registers (page 24) initialization . . . . .	93
Table 16.	User routine parameters . . . . .	95
Table 17.	Common registers . . . . .	101
Table 18.	Group F pages register map (0 to 40) . . . . .	102
Table 19.	Group F pages register map (41 to 63) . . . . .	103
Table 20.	Detailed register map . . . . .	104
Table 21.	ENCSR . . . . .	124
Table 22.	Daisy chain priority . . . . .	125
Table 23.	External interrupt channel grouping . . . . .	131
Table 24.	Multiplexed interrupt sources . . . . .	133
Table 25.	Interrupt channel assignment . . . . .	135
Table 26.	EIPLR . . . . .	142
Table 27.	SIVR . . . . .	146
Table 28.	PL bit assignment . . . . .	147
Table 29.	PL bit meaning . . . . .	147
Table 30.	Channel E to H priority levels . . . . .	148
Table 31.	Standard interrupt channel register map (Page 60) . . . . .	149
Table 32.	DM and IM meanings . . . . .	164
Table 33.	Source priority levels . . . . .	164
Table 34.	Free running clock frequency . . . . .	169
Table 35.	Summary of operating modes using main crystal controlled oscillator . . . . .	172
Table 36.	Reset flags . . . . .	177
Table 37.	PLL multiplication factors . . . . .	179
Table 38.	PLL divider factors . . . . .	179
Table 39.	Maximum RS values . . . . .	181
Table 40.	Obtained results . . . . .	182
Table 41.	I/O register map . . . . .	196
Table 42.	Control bits . . . . .	197
Table 43.	Port bit configuration table (n = 0, 1... 7; X = port number) . . . . .	197
Table 44.	Status of the I/O ports . . . . .	202
Table 45.	Interrupt configuration . . . . .	209
Table 46.	Input mode selection . . . . .	211
Table 47.	Clock input . . . . .	217
Table 48.	Output modes . . . . .	217

Table 49.	EFT pin naming conventions	218
Table 50.	Clock control bits	238
Table 51.	Extended function timer register map	240
Table 52.	Bi-value modes	246
Table 53.	Input pin function	247
Table 54.	Timer interrupt structure	254
Table 55.	Timer operating modes	262
Table 56.	TxINA pin and TxINB input pin functions	263
Table 57.	TxINA pin event	263
Table 58.	TxINB pin event	263
Table 59.	Output A action bits	264
Table 60.	Output B action bits	266
Table 61.	DMA source and destination	270
Table 62.	Interrupt sources	271
Table 63.	SCI character formats	278
Table 64.	Address interrupt modes	280
Table 65.	SCI-M baud rate generator divider values example 1	282
Table 66.	SCI-M baud rate generator divider values example 2	282
Table 67.	Receiver and transmitter clock frequencies	284
Table 68.	SCI interrupt internal priority	285
Table 69.	SCI-M interrupt vectors	285
Table 70.	Control registers	287
Table 71.	EV2 and EV1 interrupt sources	289
Table 72.	Address detection	293
Table 73.	SCI internal priorities	294
Table 74.	Number of stop bits	295
Table 75.	Number of data bits	296
Table 76.	XTCLK and OCLK coding	296
Table 77.	Transmitter and receiver parity	297
Table 78.	SCI frames	309
Table 79.	LIN synch break low phase duration	314
Table 80.	First SCI prescaler	315
Table 81.	SCI transmitter rate divisor	315
Table 82.	SCI receiver rate divisor	316
Table 83.	Serial peripheral interfaces	327
Table 84.	Serial peripheral baud rate	329
Table 85.	Prescaler baud rate	331
Table 86.	Microcontroller internal frequency INTCLK values	352
Table 87.	I2C bus register map and reset values	358
Table 88.	J1850 symbol definitions	362
Table 89.	J1850 VPW mode timing value (Tv) definitions (in clock cycles)	363
Table 90.	Normalization bit configurations	372
Table 91.	JBLPD functional modes	373
Table 92.	JBLPD internal priority levels	376
Table 93.	JBLPD interrupt vectors	376
Table 94.	Opcode definitions	386
Table 95.	Interrupt sources	396
Table 96.	Internal interrupt and DMA priorities without DMA suspend mode	396
Table 97.	Internal interrupt and DMA priorities with DMA suspend mode	397
Table 98.	Stacked registers map	402
Table 99.	Transmit mailbox mapping	420
Table 100.	Receive mailbox mapping	420

Table 101.	LEC error types . . . . .	433
Table 102.	Filter page selection . . . . .	437
Table 103.	bxCAN control & status page - register map and reset values . . . . .	449
Table 104.	bxCAN mailbox pages - register map and reset values . . . . .	450
Table 105.	bxCAN filter configuration page - register map and reset values . . . . .	451
Table 106.	Compare channels definition . . . . .	467
Table 107.	Prescaler programming . . . . .	468
Table 108.	Absolute maximum ratings . . . . .	471
Table 109.	Thermal characteristics . . . . .	472
Table 110.	Recommended operating conditions . . . . .	472
Table 111.	DC electrical characteristics . . . . .	472
Table 112.	AC electrical characteristics . . . . .	474
Table 113.	Flash / E3 TM specifications . . . . .	476
Table 114.	Susceptibility tests . . . . .	478
Table 115.	Emission test . . . . .	478
Table 116.	Absolute maximum ratings . . . . .	479
Table 117.	Electrical sensitivities . . . . .	479
Table 118.	External interrupt timing . . . . .	479
Table 119.	Wake-up management timing . . . . .	480
Table 120.	RCCU characteristics . . . . .	481
Table 121.	RCCU timing . . . . .	481
Table 122.	BOOTROM timing . . . . .	481
Table 123.	PLL characteristics . . . . .	482
Table 124.	Oscillator characteristics . . . . .	482
Table 125.	External bus timing (MC=1) . . . . .	483
Table 126.	Watchdog timing table . . . . .	484
Table 127.	Standard timer timing . . . . .	485
Table 128.	Extended function timer external timing . . . . .	486
Table 129.	Multifunction timer external timing . . . . .	487
Table 130.	SCI-M timing . . . . .	488
Table 131.	SPI timing . . . . .	489
Table 132.	I2C/DDC-bus timing . . . . .	491
Table 133.	SCL frequency . . . . .	493
Table 134.	J1850 byte level protocol decoder timing . . . . .	493
Table 135.	10-bit ADC characteristics . . . . .	494
Table 136.	ADC accuracy . . . . .	495
Table 137.	Supported part numbers . . . . .	498
Table 138.	STMicroelectronics development tools . . . . .	500
Table 139.	Suggested list of socket types . . . . .	501
Table 140.	List of limitations . . . . .	502
Table 141.	Compiled code (with -O2 optimization option) and hexa . . . . .	504
Table 142.	I2C limitations . . . . .	504
Table 143.	While loop timing . . . . .	512
Table 144.	Emulation chip limitations . . . . .	516
Table 145.	Reset behavior table . . . . .	517
Table 146.	Document revision history . . . . .	522

## List of figures

Figure 1.	ST92F124R9: Architectural block diagram	22
Figure 2.	ST92F124V1: Architectural block diagram	23
Figure 3.	ST92F150C(R/V)1/9: Architectural block diagram	24
Figure 4.	ST92F150JDV1: Architectural block diagram	25
Figure 5.	ST92F250CV2: Architectural block diagram	26
Figure 6.	ST92F124R9/R1: Pin configuration (top-view LQFP64)	29
Figure 7.	ST92F124V1: Pin configuration (top-view PQFP100)	30
Figure 8.	ST92F124V1: Pin configuration (top-view LQFP100)	31
Figure 9.	ST92F150: Pin configuration (top-view LQFP64)	32
Figure 10.	ST92F150C: Pin configuration (top-view PQFP100)	33
Figure 11.	ST92F150JD: Pin configuration (top-view PQFP100)	34
Figure 12.	ST92F150C: Pin configuration (top-view LQFP100)	35
Figure 13.	ST92F150JD: Pin configuration (top-view LQFP100)	36
Figure 14.	ST92F250: Pin configuration (top-view PQFP100)	37
Figure 15.	ST92F250: Pin configuration (top-view LQFP100)	38
Figure 16.	Recommended connections for VREG	40
Figure 17.	Minimum required connections for VREG	40
Figure 18.	Single program and data memory address space	50
Figure 19.	Register groups	50
Figure 20.	Page pointer for group F mapping	51
Figure 21.	Addressing the register file	51
Figure 22.	Pointing to a single group of 16 registers	59
Figure 23.	Pointing to two groups of 8 registers	60
Figure 24.	Internal stack mode	64
Figure 25.	External stack mode	65
Figure 26.	Page 21 registers	66
Figure 27.	Addressing via DPR[3:0]	67
Figure 28.	Addressing via CSR, ISR, and DMASR	68
Figure 29.	Memory addressing scheme (example)	72
Figure 30.	Flash memory structure (example for 64K Flash device)	75
Figure 31.	Flash memory structure (example for 128K Flash device)	76
Figure 32.	Control and status register map	78
Figure 33.	Hardware emulation flow	79
Figure 34.	Protection register map	87
Figure 35.	Test /EPB mode protection	91
Figure 36.	Access mode protection	91
Figure 37.	WRITE mode protection	92
Figure 38.	Flash in-system programming	94
Figure 39.	ST92F150/F250 external memory map	96
Figure 40.	ST92F124/F150/F250 TESTFLASH and E3 TM memory map	97
Figure 41.	ST92F124/F150 internal memory map (64K versions)	98
Figure 42.	ST92F124/F150 internal memory map (128K versions)	99
Figure 43.	ST92F250 internal memory map (256K version)	100
Figure 44.	Interrupt response	122
Figure 45.	Example of dynamic priority level modification in Nested mode	126
Figure 46.	Simple example of a sequence of interrupt requests with concurrent mode selected and IEN unchanged by the interrupt routines	127
Figure 47.	Complex example of a sequence of interrupt requests with concurrent mode	

	selected and IEN set to 1 during interrupt service routine execution . . . . .	128
Figure 48.	Simple example of a sequence of interrupt requests with Nested mode and IEN unchanged by the interrupt routines . . . . .	130
Figure 49.	Complex example of a sequence of interrupt requests with Nested mode and IEN set to 1 during the interrupt routine execution . . . . .	131
Figure 50.	Priority level examples . . . . .	132
Figure 51.	External interrupt control bits and vectors . . . . .	134
Figure 52.	Priority level examples . . . . .	135
Figure 53.	Standard interrupt (channels E to I) control bits and vectors . . . . .	136
Figure 54.	Top level interrupt structure . . . . .	138
Figure 55.	Wake-up lines / interrupt management unit block diagram. . . . .	150
Figure 56.	DMA Data Transfer. . . . .	159
Figure 57.	DMA between register file and peripheral. . . . .	160
Figure 58.	DMA between memory and peripheral . . . . .	162
Figure 59.	Clock control unit simplified block diagram. . . . .	166
Figure 60.	ST92F124/F150/F250 clock distribution diagram . . . . .	166
Figure 61.	Clock control unit programming . . . . .	168
Figure 62.	CPU clock prescaling . . . . .	170
Figure 63.	Example of low power mode programming in WFI using CK_AF external clock . . . . .	173
Figure 64.	Example of low power mode programming in WFI using CLOCK2/16 . . . . .	174
Figure 65.	RCCU general timing . . . . .	180
Figure 66.	Crystal oscillator . . . . .	181
Figure 67.	Internal oscillator schematic . . . . .	181
Figure 68.	External clock . . . . .	182
Figure 69.	Test circuit . . . . .	182
Figure 70.	Oscillator start-up sequence and reset timing . . . . .	184
Figure 71.	Recommended signal to be applied on reset pin . . . . .	185
Figure 72.	Reset pin input structure. . . . .	185
Figure 73.	Page 21 registers . . . . .	186
Figure 74.	Application example (MC=0). . . . .	188
Figure 75.	Application example (MC=1). . . . .	189
Figure 76.	External memory read/write with a programmable wait . . . . .	189
Figure 77.	Effects of DS2EN on the behavior of DS and DS2 . . . . .	190
Figure 78.	External memory Read/Write sequence with external wait request (WAIT pin) . . . . .	191
Figure 79.	Basic structure of an I/O port pin . . . . .	198
Figure 80.	Input configuration . . . . .	198
Figure 81.	Output configuration . . . . .	198
Figure 82.	Bidirectional configuration. . . . .	200
Figure 83.	Alternate function configuration . . . . .	200
Figure 84.	A/D input configuration . . . . .	201
Figure 85.	Timer/watchdog block diagram . . . . .	204
Figure 86.	Watchdog timer mode. . . . .	208
Figure 87.	Interrupt sources. . . . .	209
Figure 88.	Standard timer block diagram. . . . .	214
Figure 89.	Timer block diagram . . . . .	220
Figure 90.	16-bit read sequence (from either the counter register or the alternate counter register) . . . . .	220
Figure 91.	Counter timing diagram, INTCLK divided by 2 . . . . .	221
Figure 92.	Counter timing diagram, INTCLK divided by 4 . . . . .	222
Figure 93.	Counter timing diagram, INTCLK divided by 8 . . . . .	222
Figure 94.	Input capture block diagram . . . . .	223
Figure 95.	Input capture timing diagram . . . . .	224
Figure 96.	Output compare block diagram. . . . .	226

Figure 97.	Output compare timing diagram, internal clock divided by 2	226
Figure 98.	.One pulse mode cycle	227
Figure 99.	One pulse mode timing	228
Figure 100.	Pulse width modulation cycle	229
Figure 101.	Pulse width modulation mode timing	231
Figure 102.	MFT simplified block diagram	242
Figure 103.	Detailed block diagram	243
Figure 104.	Parallel mode description	247
Figure 105.	TxINA = Gate - TxINB = I/O signal	248
Figure 106.	TxINA = Trigger - TxINB = I/O signal	249
Figure 107.	.TxINA = Gate - TxINB = Ext. clock signal	249
Figure 108.	TxINA = Clock Up - TxINB = Clock down signal	250
Figure 109.	TxINA = Up/Down - TxINB = Ext clock signal	250
Figure 110.	TxINA = Trigger Up - TxINB = Trigger down signal	250
Figure 111.	TxINA = Up/Down - TxINB = I/O signal	251
Figure 112.	Autodiscrimination mode signal	251
Figure 113.	TxINA = Trigger - TxINB = Ext. clock signal	251
Figure 114.	Output waveforms	252
Figure 115.	Configuration example 1	253
Figure 116.	Configuration example 2	253
Figure 117.	Configuration example 3	253
Figure 118.	.Sample waveforms	254
Figure 119.	Pointer mapping for transfers between registers and memory	256
Figure 120.	Pointer mapping for register to register transfers	256
Figure 121.	SCI-M block diagram	274
Figure 122.	SCI -M functional schematic	275
Figure 123.	Sampling times in asynchronous format	276
Figure 124.	SCI -M operating modes	277
Figure 125.	SCI signal	278
Figure 126.	Auto echo configuration	280
Figure 127.	Loop back configuration	280
Figure 128.	Auto echo and loop-back configuration	280
Figure 129.	SCI-M baud rate generator initialization sequence	282
Figure 130.	SCI-M interrupts: example of typical usage	285
Figure 131.	SCI-A block diagram	302
Figure 132.	Word length programming	303
Figure 133.	SCI baud rate and extended prescaler block diagram	307
Figure 134.	Serial peripheral interface master/slave	318
Figure 135.	Serial peripheral interface block diagram	319
Figure 136.	CPHA / SS timing diagram	322
Figure 137.	Data clock timing diagram	323
Figure 138.	Clearing the WCOL bit (write collision flag) software sequence	324
Figure 139.	Single master configuration	326
Figure 140.	I2C interface block diagram	333
Figure 141.	I2C bus protocol	335
Figure 142.	Event flags and interrupt generation	340
Figure 143.	JBLPD byte level protocol decoder block diagram	361
Figure 144.	J1850 string transmission type 0	366
Figure 145.	J1850 string transmission type 1	366
Figure 146.	J1850 string transmission type 2	367
Figure 147.	J1850 string transmission type 3	367
Figure 148.	J1850 arbitration example	368

Figure 149. J1850 received symbol timing . . . . .	369
Figure 150. I.D. byte and message filter array use . . . . .	371
Figure 151. Local loopback structure . . . . .	373
Figure 152. DMA in reception mode . . . . .	378
Figure 153. DMA in transmission mode . . . . .	380
Figure 154. JBLPD register map . . . . .	381
Figure 155. CAN network topology . . . . .	407
Figure 156. CAN block diagram . . . . .	409
Figure 157. bxCAN operating modes . . . . .	409
Figure 158. bxCAN in silent mode . . . . .	411
Figure 159. bxCAN in loop back mode . . . . .	411
Figure 160. bxCAN in combined mode . . . . .	412
Figure 161. Transmit mailbox states . . . . .	413
Figure 162. Receive FIFO states . . . . .	414
Figure 163. Filter bank scale configuration - register organization . . . . .	417
Figure 164. Filtering mechanism - example . . . . .	419
Figure 165. CAN error state diagram . . . . .	421
Figure 166. Bit timing . . . . .	423
Figure 167. CAN frames . . . . .	424
Figure 168. Event flags and interrupt generation . . . . .	425
Figure 169. Page mapping for CAN 0 / CAN 1 . . . . .	448
Figure 170. Page mapping for CAN0 /CAN1 (continued) . . . . .	449
Figure 171. ADC block diagram . . . . .	452
Figure 172. Analog watchdog function . . . . .	455
Figure 173. ADC trigger source . . . . .	455
Figure 174. Application example: analog watchdog used in motor speed control . . . . .	455
Figure 175. Stop mode current . . . . .	476
Figure 176. Evolution of worst case E3 page update time . . . . .	477
Figure 177. External interrupt timing . . . . .	480
Figure 178. Wake-up management timing . . . . .	480
Figure 179. External bus timing . . . . .	484
Figure 180. Watchdog timing . . . . .	485
Figure 181. Standard timer timing . . . . .	486
Figure 182. Extended function timer external timing . . . . .	486
Figure 183. Multifunction timer external timing . . . . .	487
Figure 184. SCI timing . . . . .	488
Figure 185. SPI master timing diagram CPHA=0, CPOL=0 . . . . .	490
Figure 186. SPI master timing diagram CPHA=0, CPOL=1 . . . . .	490
Figure 187. SPI Master timing diagram CPHA=1, CPOL=0 . . . . .	490
Figure 188. SPI Master timing diagram CPHA=1, CPOL=1 . . . . .	490
Figure 189. SPI Slave timing diagram CPHA=0, CPOL=0 . . . . .	490
Figure 190. SPI slave timing diagram CPHA=0, CPOL=1 . . . . .	491
Figure 191. SPI slave timing diagram CPHA=1, CPOL=0 . . . . .	491
Figure 192. SPI slave timing diagram CPHA=1, CPOL=1 . . . . .	491
Figure 193. I2C timing . . . . .	492
Figure 194. J1850 protocol timing . . . . .	494
Figure 195. Typical application with ADC . . . . .	495
Figure 196. ADC accuracy characteristics . . . . .	496
Figure 197. Device types . . . . .	497
Figure 198. 64-pin low profile quad flat package . . . . .	499
Figure 199. 100-pin low profile quad flat package . . . . .	499
Figure 200. 100-pin plastic quad flat package . . . . .	500

Figure 201. Mute mode mechanism on address mark. ....	507
Figure 202. FIFO corruption. ....	509
Figure 203. Workaround 1 in assembler . ....	510
Figure 204. Critical window timing diagram . ....	511
Figure 205. Reception of a sequence of frames . ....	511
Figure 206. Reception with TCAN=12/fCPU and sampling time is 16/fCPU . ....	512
Figure 207. Workaround 2 in assembler . ....	513
Figure 208. Multifunction timer. ....	514
Figure 209. Impact of negative current injection on adjacent pin. ....	518

**Table 2. Detailed device summary <sup>(1)</sup>**

Features	ST92F124xx		ST92F150Cxx		ST92F150JDV 1	ST92F250CV 2
	ST92F124R1 ST92F124R9	ST92F124V1	ST92F150CR1 ST92F150CR9	ST92F150CV1 ST92F150CV9		
FLASH - bytes	64 Kbytes/ 128 Kbytes	128 Kbytes	64Kbytes/ 128 Kbytes	64 Kbytes/ 128 Kbytes	128 Kbytes	256 Kbytes
RAM - bytes	2 Kbytes/ 4 Kbytes	4 Kbytes	2 Kbytes/4 Kbytes	2 Kbytes/ 4 Kbytes	6 Kbytes	8 Kbytes
E <sup>3</sup> ™ - bytes	1 Kbyte	1 Kbyte	1 Kbyte	1 Kbyte	1 Kbyte	1 Kbyte
Timers and Serial Interface	2 MFT, 2 EFT, STIM, WD, SCI, SPI, I <sup>2</sup> C	2 MFT, 2 EFT, STIM, WD, 2 SCI, SPI, I <sup>2</sup> C	2 MFT, 2 EFT, STIM, WD, SCI, SPI, I <sup>2</sup> C	2 MFT, 2 EFT, STIM, WD, 2 SCI, SPI, I <sup>2</sup> C	2 MFT, 2 EFT, STIM, WD, 2 SCI, SPI, I <sup>2</sup> C	2 MFT, 2 EFT, STIM, WD, 2 SCI, SPI, 2 I <sup>2</sup> C <sup>(2)</sup>
ADC	16 x 10 bits	16 x 10 bits	16 x 10 bits	16 x 10 bits	16 x 10 bits	16 x 10 bits
Network Interface	-	LIN Master	CAN	CAN, LIN Master	2 CAN, J1850, LIN Master	CAN, LIN Master
Packages	LQFP64	P/LQFP100	LQFP64	P/LQFP100	P/LQFP100	

1. see [Table 137: Supported part numbers on page 498](#) for the list of supported part numbers.
2. see [Section 16.4 on page 500](#) for important information.

# 1 Description

The ST92F124/F150/F250 microcontroller is developed and manufactured by STMicroelectronics using a proprietary n-well HCMOS process. Its performance derives from the use of a flexible 256-register programming model for ultra-fast context switching and real-time event response. The intelligent on-chip peripherals offload the ST9 core from I/O and data management processing tasks allowing critical application tasks to get the maximum use of core resources. The new-generation ST9 MCU devices now also support low power consumption and low voltage operation for power-efficient and low-cost embedded systems.

## ST9+ core

The advanced Core consists of the Central Processing Unit (CPU), the Register File, the Interrupt and DMA controller, and the Memory Management Unit. The MMU allows a single linear address space of up to 4 Mbytes.

Four independent buses are controlled by the Core: a 22-bit memory bus, an 8-bit register data bus, an 8-bit register address bus and a 6-bit interrupt/DMA bus which connects the interrupt and DMA controllers in the on-chip peripherals with the core.

This multiple bus architecture makes the ST9 family devices highly efficient for accessing on and off-chip memory and fast exchange of data with the on-chip peripherals.

The general-purpose registers can be used as accumulators, index registers, or address pointers. Adjacent register pairs make up 16-bit registers for addressing or 16-bit processing. Although the ST9 has an 8-bit ALU, the chip handles 16-bit operations, including arithmetic, loads/stores, and memory/register and memory/memory exchanges.

The powerful I/O capabilities demanded by microcontroller applications are fulfilled by the ST92F150/F124 with 48 (64-pin devices) or 77 (100-pin devices) I/O lines dedicated to digital Input/Output and with 80 I/O lines by the ST92F250. These lines are grouped into up to ten 8-bit I/O Ports and can be configured on a bit basis under software control to provide timing, status signals, an address/data bus for interfacing to the external memory, timer inputs and outputs, analog inputs, external interrupts and serial or parallel I/O. Two memory spaces are available to support this wide range of configurations: a combined Program/Data Memory Space and the internal Register File, which includes the control and status registers of the on-chip peripherals.

## External memory interface

100-pin devices have a 22-bit external address bus allowing them to address up to 4 Mbytes of external memory.

## On-chip peripherals

Two 16-bit Multifunction Timers, each with an 8 bit Prescaler and 12 operating modes, allow simple use for complex waveform generation and measurement, PWM functions and many other system timing functions by the usage of the two associated DMA channels for each timer.

Two Extended Function Timers provide further timing and signal generation capabilities.

A Standard Timer can be used to generate a stable time base independent from the PLL.

An I<sup>2</sup>C interface (two in the ST92F250 device) provides fast I<sup>2</sup>C and Access Bus support.

The SPI is a synchronous serial interface for Master and Slave device communication. It supports single master and multimaster systems.

A J1850 Byte Level Protocol Decoder is available (ST92F150JDV1 device only) for communicating with a J1850 network.

The bxCAN (basic extended) interface (two in the ST92F150JDV1 device) supports 2.0B Active protocol. It has 3 transmit mailboxes, 2 independent receive FIFOs and 8 filters.

In addition, there is a 16 channel Analog to Digital Converter with integral sample and hold, fast conversion time and 10-bit resolution.

There is one Multiprotocol Serial Communications Interface with an integral generator, asynchronous and synchronous capability (fully programmable format) and associated address/wake-up option, plus two DMA channels.

On 100-pin devices, there is an additional asynchronous Serial Communications interface with 13-bit LIN Synch Break generation capability.

Finally, a programmable PLL Clock Generator allows the usage of standard 3 to 5 MHz crystals to obtain a large range of internal frequencies up to 24 MHz. Low power Run (SLOW), Wait For Interrupt, low power Wait For Interrupt, STOP and HALT modes are also available.

Figure 1. ST92F124R9: Architectural block diagram

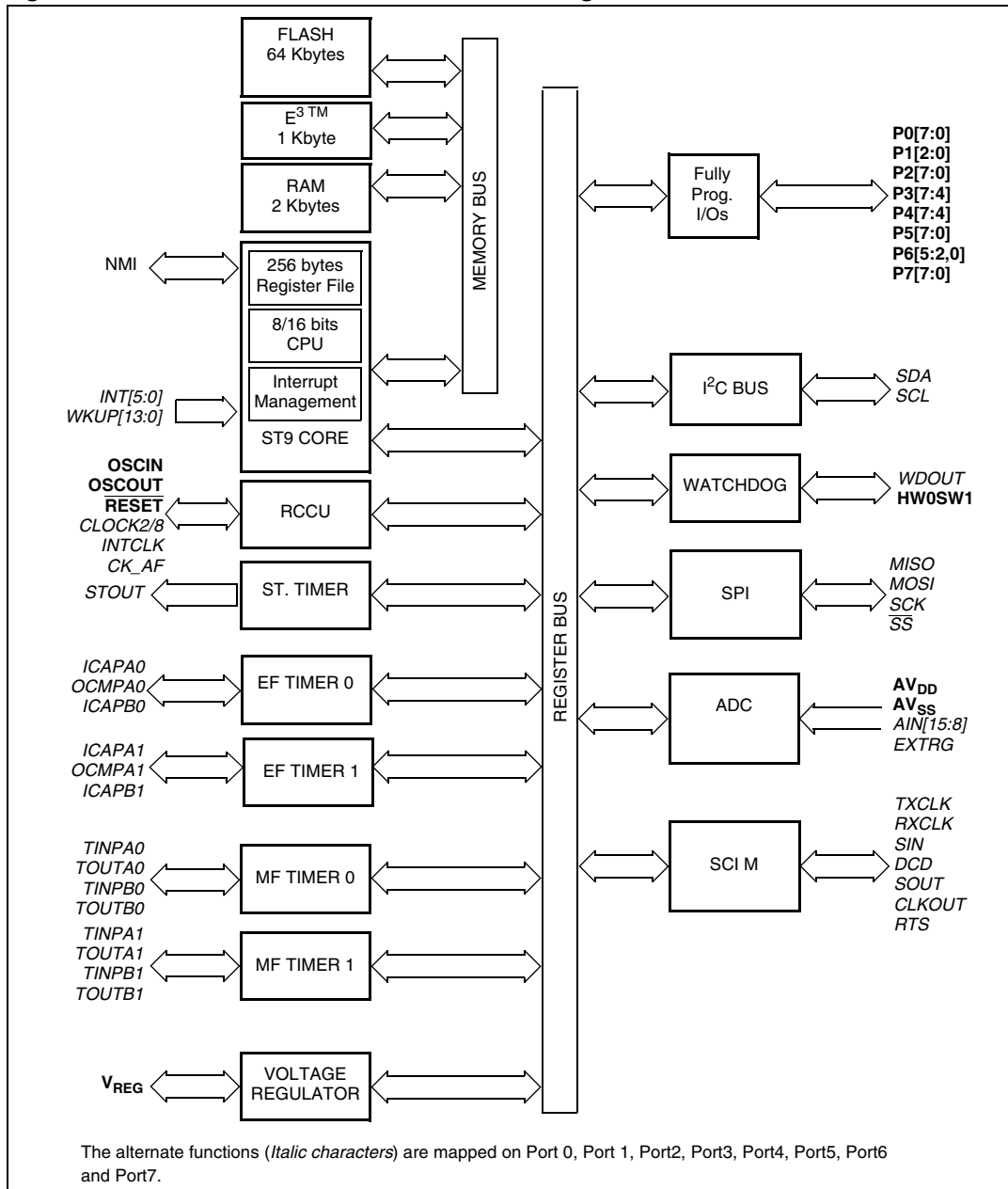

Figure 2. ST92F124V1: Architectural block diagram

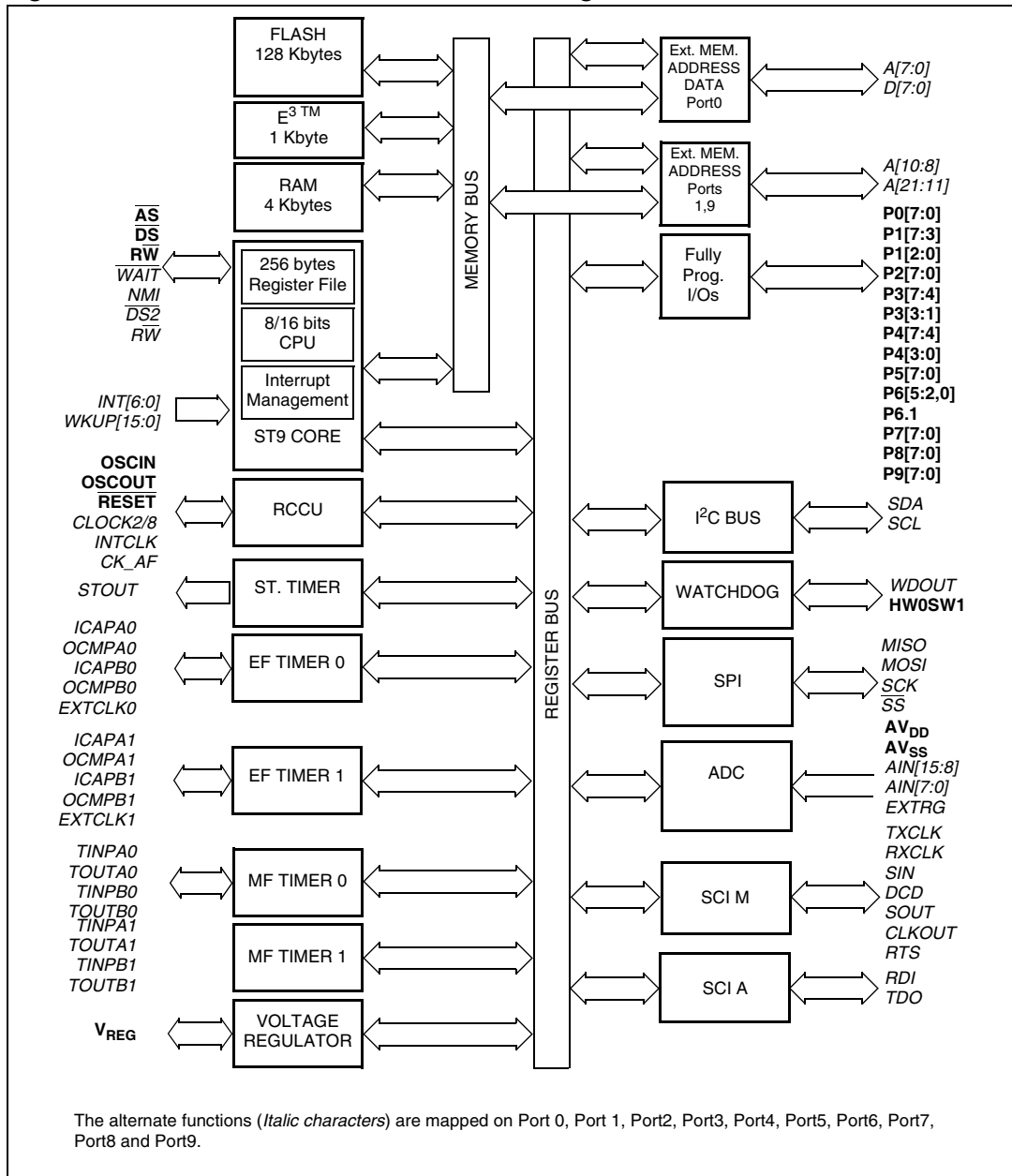

Figure 3. ST92F150C(R/V)1/9: Architectural block diagram

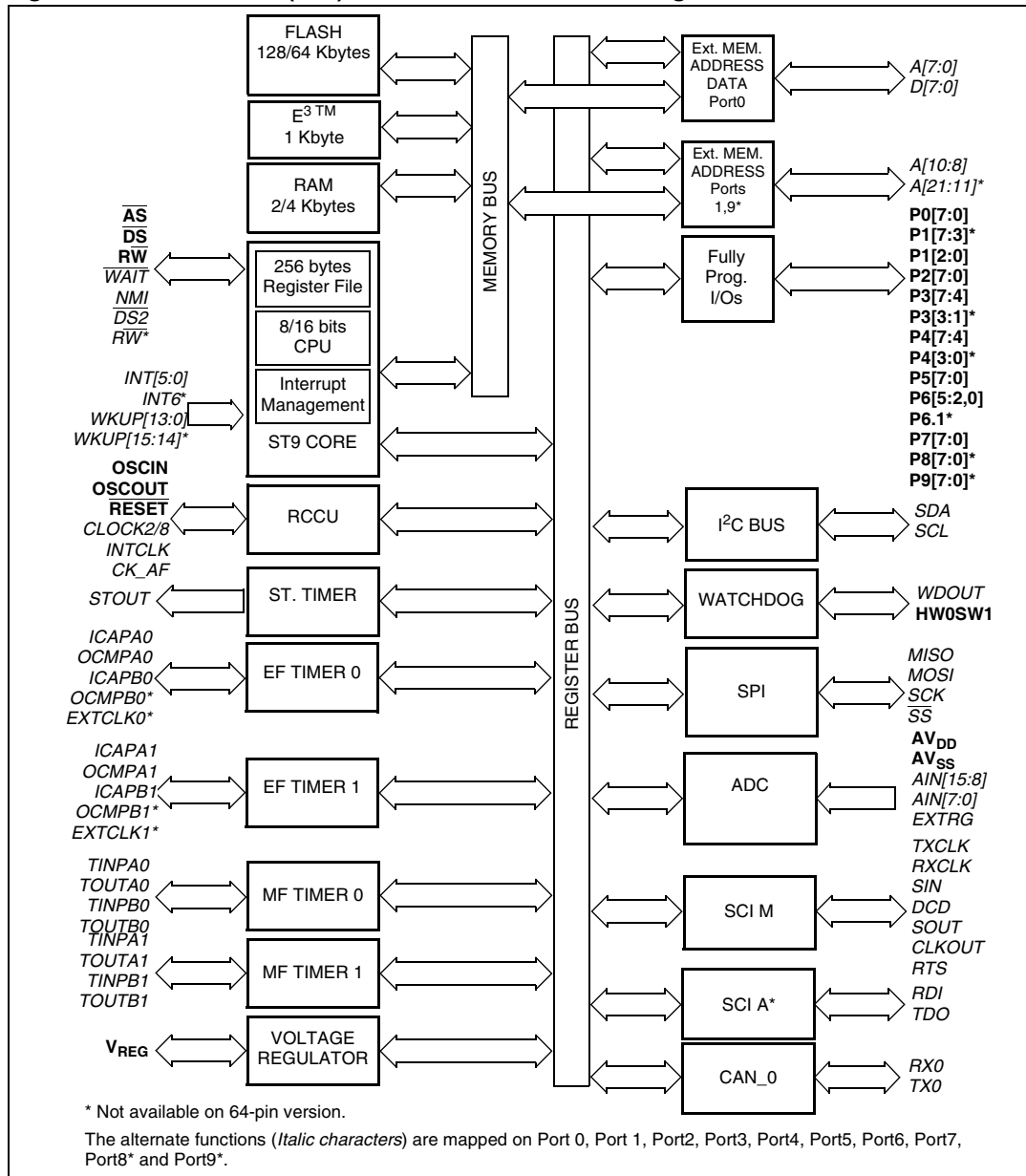

Figure 4. ST92F150JDV1: Architectural block diagram

