



Chipsmall Limited consists of a professional team with an average of over 10 year of expertise in the distribution of electronic components. Based in Hongkong, we have already established firm and mutual-benefit business relationships with customers from,Europe,America and south Asia,supplying obsolete and hard-to-find components to meet their specific needs.

With the principle of "Quality Parts,Customers Priority,Honest Operation,and Considerate Service",our business mainly focus on the distribution of electronic components. Line cards we deal with include Microchip,ALPS,ROHM,Xilinx,Pulse,ON,Everlight and Freescale. Main products comprise IC,Modules,Potentiometer,IC Socket,Relay,Connector.Our parts cover such applications as commercial,industrial, and automotives areas.

We are looking forward to setting up business relationship with you and hope to provide you with the best service and solution. Let us make a better world for our industry!



## Contact us

Tel: +86-755-8981 8866 Fax: +86-755-8427 6832

Email & Skype: info@chipsmall.com Web: www.chipsmall.com

Address: A1208, Overseas Decoration Building, #122 Zhenhua RD., Futian, Shenzhen, China



## MPEG 2.5 LAYER III AUDIO DECODER WITH ADPCM CAPABILITY

- SINGLE CHIP MPEG2 LAYER 3 DECODER SUPPORTING:
  - All features specified for Layer III in ISO/IEC 11172-3 (MPEG 1 Audio)
  - All features specified for Layer III in ISO/IEC 13818-3.2 (MPEG 2 Audio)
  - Lower sampling frequencies syntax extension, (not specified by ISO) called MPEG 2.5
- DECODES LAYER III STEREO CHANNELS, DUAL CHANNEL, SINGLE CHANNEL (MONO)
- SUPPORTING ALL THE MPEG 1 & 2 SAMPLING FREQUENCIES AND THE EXTENSION TO MPEG 2.5:  
48, 44.1, 32, 24, 22.05, 16, 12, 11.025, 8 KHz
- ACCEPTS MPEG 2.5 LAYER III ELEMENTARY COMPRESSED BITSTREAM WITH DATA RATE FROM 8 Kbit/s UP TO 320 Kbit/s
- ADPCM CODEC CAPABILITIES:
  - sample frequency from 8 kHz to 32 kHz
  - sample size from 8 bits to 32 bits
  - encoding algorithm: DVI, ITU-G726 pack (G723-24, G721, G723-4C)
  - Tone control and fast-forward capability
- EASY PROGRAMMABLE GPIO INTERFACE FOR ENCODED DATA UP TO 5 Mbit/s (TQFP44 & LFBGA 64)
- DIGITAL VOLUME CONTROL
- DIGITAL BASS & TREBLE CONTROL
- BYPASS MODE FOR EXTERNAL AUDIO SOURCE
- SERIAL BITSTREAM INPUT INTERFACE
- EASY PROGRAMMABLE ADC INPUT INTERFACE
- ANCILLARY DATA EXTRACTION VIA I<sup>2</sup>C INTERFACE.
- SERIAL PCM OUTPUT INTERFACE (I<sup>2</sup>S AND OTHER FORMATS)
- PLL FOR INTERNAL CLOCK AND FOR OUTPUT PCM CLOCK GENERATION
- CRC CHECK AND SYNCHRONISATION ERROR DETECTION WITH SOFTWARE

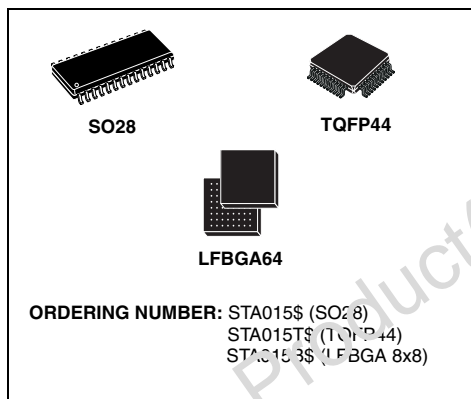

### INDICATORS

- I<sup>2</sup>C CONTROL BUS
- LOW POWER 2.4V CMOS TECHNOLOGY
- WIDE RANGE OF EXTERNAL CRYSTALS FREQUENCIES SUPPORTED

### APPLICATIONS

- PC SOUND CARDS
- MULTIMEDIA PLAYERS
- VOICE RECORDERS

### DESCRIPTION

The STA015 is a fully integrated high flexibility MPEG Layer III Audio Decoder, capable of decoding Layer III compressed elementary streams, as specified in MPEG 1 and MPEG 2 ISO standards. The device decodes also elementary streams compressed by using low sampling rates, as specified by MPEG 2.5. STA015 receives the input data through a Serial input Interface. The decoded signal is a stereo, mono, or dual channel digital output that can be sent directly to a D/A converter, by the PCM Output Interface.

This interface is software programmable to adapt the STA015 digital output to the most common DACs architectures used on the market. The functional STA015 chip partitioning is described in Fig.1a and Fig.1b.

Figure 1.

1a. Block Diagram for TQFP44 and LFBGA64 package.

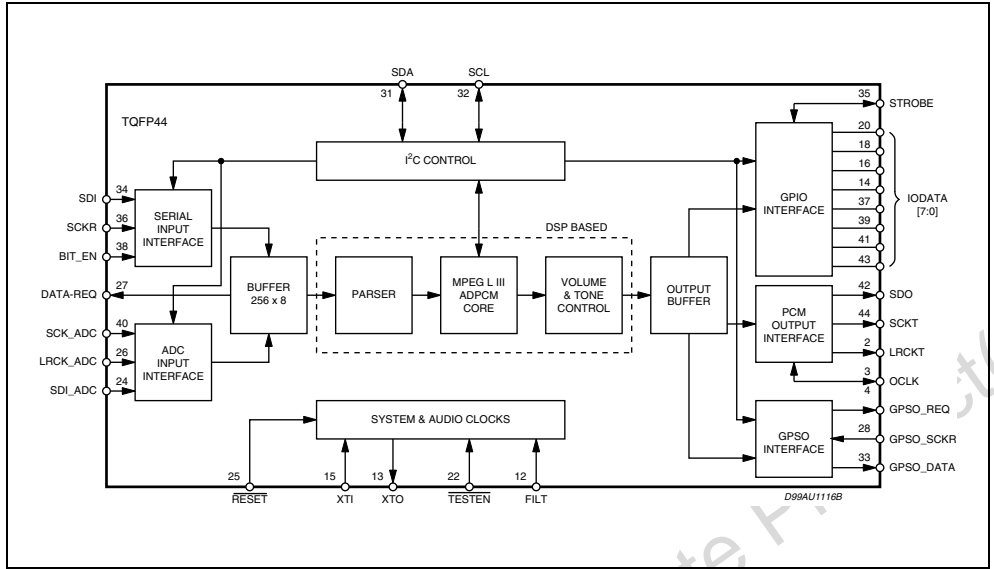

1b. BLOCK DIAGRAM for SO28 package

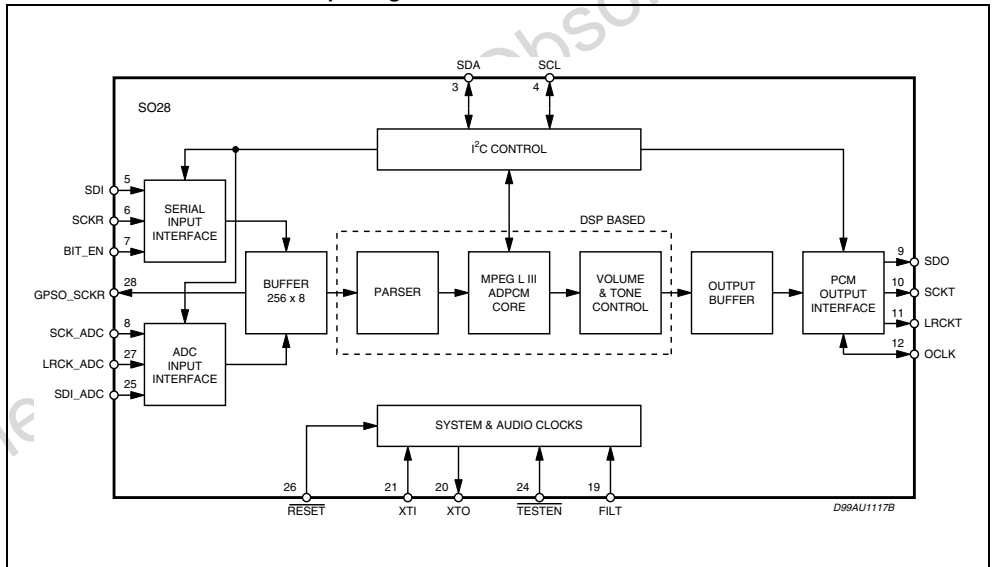
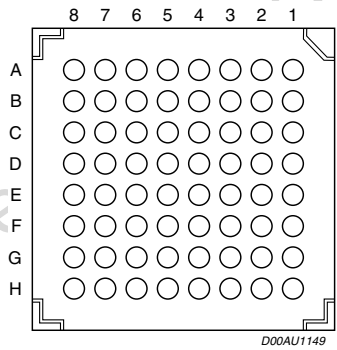
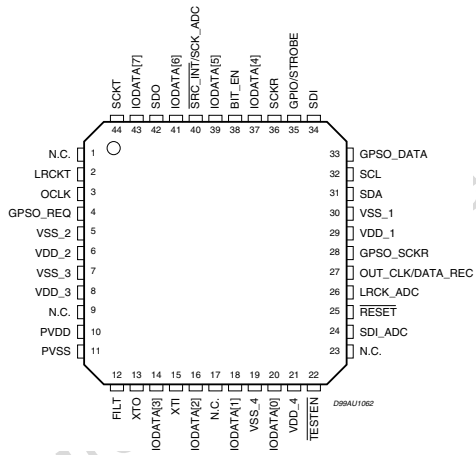
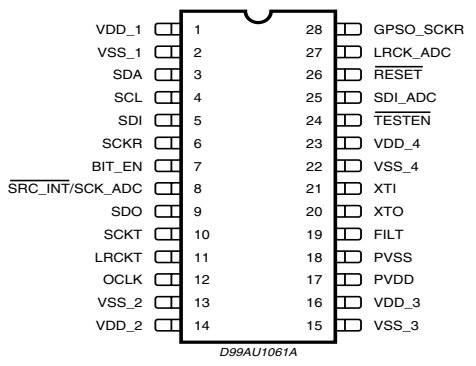

Figure 2. Pin Connection



- |              |                       |                  |
|--------------|-----------------------|------------------|
| A1 = SDI     | G7 = FILT             | C2 = GPIO_STROBE |
| B2 = SCKR    | G8 = XTO              | C3 = IODATA [4]  |
| D4 = BIT_EN  | F7 = XTI              | E3 = IODATA [5]  |
| D1 = SRC_INT | E7 = VSS_4            | D2 = IODATA [6]  |
| E2 = SDO     | C8 = VDD_4            | F1 = IODATA [7]  |
| F2 = SCKT    | D7 = TESTEN           | G3 = GPSO_REQ    |
| H1 = LRCKT   | A7 = SDI_ADC          | F8 = IODATA [3]  |
| H3 = OCLK    | B6 = RESET            | F6 = IODATA [2]  |
| F3 = VSS_2   | A5 = LRCK_ADC         | E6 = IODATA [1]  |
| E4 = VDD_2   | C5 = OUT_CLK/DATA_REQ | C7 = IODATA [0]  |
| G4 = VSS_3   | B5 = VDD_1            | C6 = GPSO_SCKR   |
| G5 = VDD_3   | B4 = VSS_1            | A2 = GPSO_DATA   |
| F5 = PVDD    | A4 = SDA              |                  |
| G6 = PVSS    | B3 = SCL              |                  |

LFBGA64



## 1.0 OVERVIEW

### 1.1 MP3 decoder engine

The MP3 decoder engine is able to decode any Layer III compliant bitstream: MPEG1, MPEG2 and MPEG2.5 streams are supported. Besides audio data decoding the MP3 engine also performs ANCILLARY data extraction: these data can be retrieved via I<sup>2</sup>C bus by the application microcontroller in order to implement specific functions.

Decoded audio data goes through a software volume control and a two-band equalizer blocks before feeding the output I2S interface. This results in no need for an external audio processor.

MP3 bitstream is sent to the decoder using a simple serial input interface (see pins SDI, SCKR, BIT\_EN and DATA\_REQ), supporting input rate up to 20 Mbit/s. Received data are stored in a 256 bytes long input buffer which provides a feedback line (see DATA\_REQ pin) to the bitstream source (typically an MCU).

### 1.2 ADPCM encoder/decoder engine

This device also embeds a multistandard ADPCM encoder/decoder supporting different sample rates (from 8 KHz up to 32 KHz) and different sample sizes (from 8 bit to 32 bits).

During encoding process two different interfaces can be used to feed data: the serial input interface (same interface used also to feed MP3 bitstream) or the ADC input interface, which provides a seamless connection with an external A/D converter. The currently used interface is selected via I<sup>2</sup>C bus.

Also to retrieve encoded data two different interfaces are available: the I<sup>2</sup>C bus or the faster GPSO output interface. GPSO interface is able to output data with a bitrate up to 5 Mbit/s and its control pins (GPSO\_SCKR, GPSO\_DATA and GPSO\_REQ) can be configured in order to easily fit the target application.

### 1.3 BYPASS functional mode

In order to allow using the device to post-process auxiliary audio sources a special BYPASS mode is available. When the device is configured in BYPASS mode the embedded DSP will process digital audio data coming through the ADC input interface and will output the resulting data to the external DAC.

Available processings include volume and a tone controls.

## THERMAL DATA

Symbol	Parameter	Value	Unit
Rth j-amb	Thermal resistance Junction to Ambient	85	°C/W

## ABSOLUTE MAXIMUM RATINGS

Symbol	Parameter	Value	Unit
V <sub>DD</sub>	Power Supply	-0.3 to 4	V
V <sub>i</sub>	Voltage on Input pins	-0.3 to V <sub>DD</sub> +0.3	V
V <sub>o</sub>	Voltage on output pins	-0.3 to V <sub>DD</sub> +0.3	V
T <sub>stg</sub>	Storage Temperature	-40 to +150	°C
T <sub>oper</sub>	Operative ambient temp	-20 to +85	°C

## PIN DESCRIPTION

SO28	TQFP44	LFBGA64	Pin Name	Type	Function	PAD Description
1	29	B5	VDD_1		Supply Voltage	
2	30	B4	VSS_1		Ground	
3	31	A4	SDA	I/O	I <sup>2</sup> C Serial Data + Acknowledge	CMOS Input Pad Buffer CMOS 4mA Output Drive
4	32	B3	SCL	I	I <sup>2</sup> C Serial Clock	CMOS Input Pad Buffer
5	34	A1	SDI	I	Receiver Serial Data	CMOS Input Pad Buffer
6	36	B2	SCKR	I	Receiver Serial Clock	CMOS Input Pad Buffer
7	38	D4	BIT_EN	I	Bit Enable	CMOS Input Pad Buffer with pull up
8	40	D1	SRC_INT/ SCK_ADC	I	Interrupt Line/ADC Serial Clock	CMOS Input Pad Buffer
9	42	E2	SDO	O	Transmitter Serial Data (PCM Data)	CMOS 4mA Output Drive
10	44	F2	SCKT	O	Transmitter Serial Clock	CMOS 4mA Output Drive
11	2	H1	LRCKT	O	Transmitter Left/Right Clock	CMOS 4mA Output Drive
12	3	H3	OCLK	I/O	Oversampling Clock for DAC	CMOS Input Pad Buffer CMOS 4mA Output Drive
13	5	F3	VSS_2		Ground	
14	6	E4	VDD_2		Supply Voltage	
15	7	G4	VSS_3		Ground	
16	8	G5	VDD_3		Supply Voltage	
17	10	F5	PVDD		PLL Power	
18	11	G6	PVSS		PLL Ground	
19	12	G7	FILT	O	PLL Filter Ext. Capacitor Conn.	
20	13	G8	XTO	O	Crystal Output	CMOS 4mA Output Drive
21	15	F7	XTI	I	Crystal Input (Clock Input)	Specific Level Input Pad (see paragraph 2.1)
22	19	E7	VSS_4		Ground	
23	21	C8	VDD_4		Supply Voltage	
24	22	D7	TESTEN	I	Test Enable	CMOS Input Pad Buffer with pull up
25	24	A7	SDI_ADC	I	ADC Data Input	CMOS Input Pad Buffer
26	25	B6	RESET	I	System Reset	CMOS Input Pad Buffer with pull up
27	26	A5	LRCK_ADC	I	ADC left/Right Clock	CMOS Output Pad Buffer
28	27	C5	IN_CLK/ DATA_REQ	O	Buffered Output Clock/ Data Request Signal	CMOS 4mA Output Drive
20		C7	IODATA[0]	I/O	GPIO Data Line	CMOS 4mA Schmitt Trigger Bidir Pad Buffer
18		E6	IODATA[1]	I/O	GPIO Data Line	
16		F6	IODATA[2]	I/O	GPIO Data Line	
14		F8	IODATA[3]	I/O	GPIO Data Line	
37		C3	IODATA[4]	I/O	GPIO Data Line	
39		E3	IODATA[5]	I/O	GPIO Data Line	
41		D2	IODATA[6]	I/O	GPIO Data Line	
43		F1	IODATA[7]	I/O	GPIO Data Line	
35		C2	GPIO_STROBE	I/O	GPIO Strobe Signal	
4		G3	GPSO_REQ	O	GPSO Request Signal	
28		C6	GPSO_SCKR	I	GPSO Serial Clock	CMOS Input Pad Buffer
33		A2	GPSO_DATA	O	GPSO Serial Data	CMOS Output Pad Buffer

Note: In functional mode TESTEN must be connected to VDD.

**ELECTRICAL CHARACTERISTICS:**  $V_{DD} = 3.3V \pm 0.3V$ ;  $T_{amb} = 0$  to  $70^{\circ}C$ ;  $R_g = 50\Omega$  unless otherwise specified

**DC OPERATING CONDITIONS**

Symbol	Parameter	Value
$V_{DD}$	Power Supply Voltage	2.4 to 3.6V
$T_j$	Operating Junction Temperature	-20 to $125^{\circ}C$

**GENERAL INTERFACE ELECTRICAL CHARACTERISTICS**

Symbol	Parameter	Test Condition	Min.	Typ.	Max.	Unit	Note
$I_{IL}$	Low Level Input Current Without pull-up device	$V_i = 0V$	-10		10	$\mu A$	1
$I_{IH}$	High Level Input Current Without pull-up device	$V_i = V_{DD}$	-10		10	$\mu A$	1
$V_{esd}$	Electrostatic Protection	Leakage $< 1\mu A$	2000			V	2

Notes: 1. The leakage currents are generally very small,  $< 1nA$ . The value given here is a maximum that can occur after an electrostatic stress on the pin.  
 2. Human Body Model.

**DC ELECTRICAL CHARACTERISTICS**

Symbol	Parameter	Test Condition	Min.	Typ.	Max.	Unit	Note
$V_{IL}$	Low Level Input Voltage				$0.2 \cdot V_{DD}$	V	
$V_{IH}$	High Level Input Voltage		$0.8 \cdot V_{DD}$			V	
$V_{OL}$	Low Level Output Voltage	$I_{ol} = Xma$			0.4V	V	1, 2
$V_{OH}$	High Level Output Voltage		$0.85 \cdot V_{DD}$			V	1, 2

Notes: 1. Takes into account 200mV voltage drop in both supply lines.  
 2. X is the source/sink current under worst case conditions and is reflected in the name of the I/O cell according to the drive capability.

Symbol	Parameter	Test Condition	Min.	Typ.	Max.	Unit	Note
$I_{pu}$	Pull-up current	$V_i = 0V$ ; pin numbers 7, 24 and 26;	-25	-66	-125	$\mu A$	1
$R_{pu}$	Equivalent Pull-up Resistance			50		$k\Omega$	

Notes: 1. Min. condition:  $V_{DD} = 2.7V$ ,  $125^{\circ}C$  Min process  
 Max. condition:  $V_{DD} = 3.6V$ ,  $-20^{\circ}C$  Max.

**POWER DISSIPATION**

Symbol	Parameter	Test Condition	Min.	Typ	Max	Unit	Note
$P_D$	Power Dissipation @ $V_{DD} = 2.4V$	Sampling_freq $\leq 24$ kHz		76		mW	
		Sampling_freq $\leq 32$ kHz		79		mW	
		Sampling_freq $\leq 48$ kHz		85		mW	

Figure 3. Test Circuit

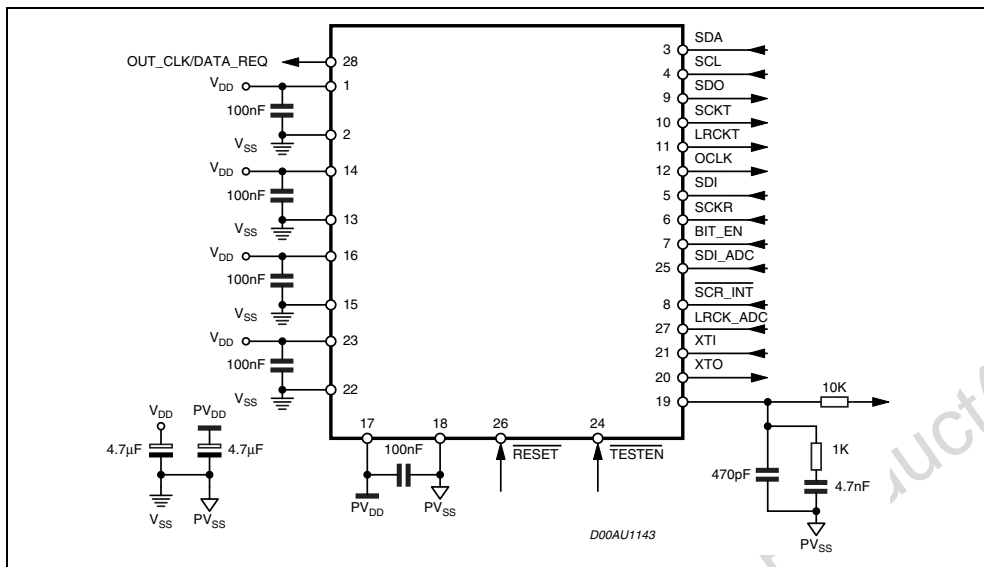
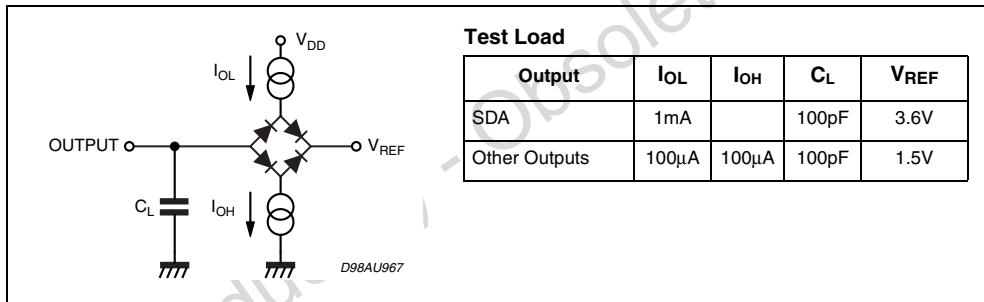

Figure 4. Test Load Circuit



2.0 FUNCTIONAL DESCRIPTION

2.1 Clock Signal

The STA015 input clock is derived from an external source or from a industry standard crystal oscillator, generating input frequencies of 10, 14.31818 or 14.7456 MHz.

Other frequencies may be supported upon request to STMicroelectronics. Each frequency is supported by downloading a specific configuration file, provided by STM XT1 is an input Pad with specific levels.

Symbol	Parameter	Test Condition	Min.	Typ.	Max.	Unit
V <sub>IL</sub>	Low Level Input Voltage				V <sub>DD</sub> -1.8	V
V <sub>IH</sub>	High Level Input Voltage		V <sub>DD</sub> -0.8			V



CMOS compatibility

The XTI pad low and high levels are CMOS compatible; XTI pad noise margin is better than typical CMOS pads.

TTL compatibility

The XTI pad low level is compatible with TTL while the high level is not compatible (for example if  $V_{DD} = 3V$  TTL min high level = 2.0V while XTI min high level = 2.2V)

**2.2 PLL & Clock Generator System**

When STA015 receives the input clock, as described in Section 2.1, and a valid layer III input bit stream, the internal PLL locks, providing to the DSP Core the master clock (DCLK), and to the Audio Output Interface the nominal frequencies of the incoming compressed bit stream. The STA015 PLL block diagram is described in Figure 5.

The audio sample rates are obtained dividing the oversampling clock (OCLK) by software programmable factors. The operation is done by STA015 embedded software and it is transparent to the user.

The STA015 PLL can drive directly most of the commercial DACs families, providing an over sampling clock, OCLK, obtained dividing the VCO frequency with a software programmable dividers.

**Figure 5. PLL and Clocks Generation System**

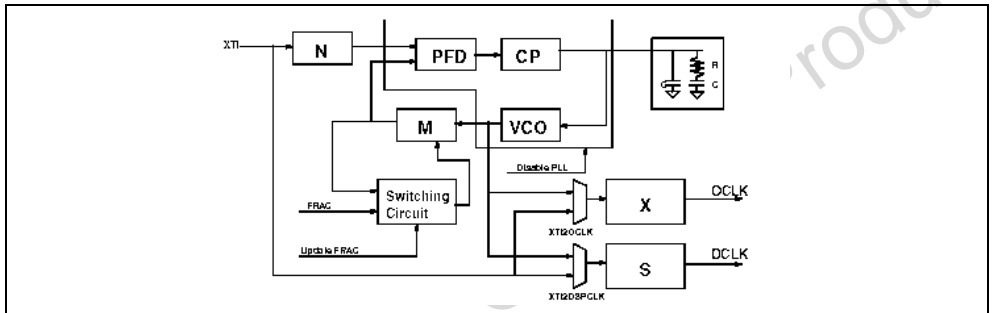

**2.3 STA015 Operational Modes**

The device can be configured in 4 different operational modes. To select one specific mode a dedicated CHIP\_MODE registers is available. For proper operation the following steps must be issued to switch between different modes:

- issue a software reset (SOFT\_RESET register)
- select the desired mode (CHIP\_MODE register)
- run the device (RUN register)

Hereby is a short description of each available mode

■ **ADPCM Encoder**

This mode can be used to encode the incoming bitstream with 4 different compression algorithms. Moreover different sample frequencies and word size are supported. For a detailed description of this features refer to the related registers.

■ **ADPCM Decoder**

This mode can be used when an ADPCM compressed bitstream must be decoded. The input interface handling and control flow is the same as in the MP3 Mode.

■ **BYPASS mode**

Using this mode it's possible to use the embedded post-processing controls (volume and tone controls) to process an incoming uncompressed stereo audio stream. In this configuration ADC input is the only

supported interface. This could be useful, for instance, to process audio data coming from an external tuner or some other auxiliary source.

■ **MP3 mode**

In MP3 Mode (default mode) STA015 decodes the incoming bitstream, acting as a master of the data communication from the source to itself. This control is done by a specific buffer management, controlled by STA015 embedded software.

The data coming from the serial interface are stored in the input buffer, a 256 bytes long FIFO.

The feedback line DATA\_REQ actually is the result of the h/w comparison between the writing address of the FIFO and the constant value 252. This means that if the buffer is filled up with more than 252 bytes the DATA\_REQ line goes low, requesting MCU to stop transmission: the maximum time to stop transmitting is given by the time required to transmit 4 bytes (this time, in turn, depends on the bitstream speed used to send MP3 data).

The input interface can receive data with a speed up to 20Mbit/s. The speed at which the FIFO is emptied is equal to the MP3 nominal bitrate. Provided the FIFO is filled up with 252 bytes the time required to empty it (in worst condition, which is 320kbit/s mpeg stream) is about 6ms. So if no more data is received in this time the buffer will be emptied and this will badly affect the output audio.

In this mode the fractional part of the PLL is disabled and the audio clocks are generated at nominal rates. Fig. 6 describes the default DATA\_REQ signal behaviour. Programming STA015 it is possible to invert the polarity of the DATA\_REQ line (register REQ\_POL).

In order to allow proper operation of the device in broadcast applications a special BROADCAST MP3 decoding mode is available. When configured in BROADCAST mode the device will operate as a slave decoder and no more feedback will be generated to the data source.

The output PCM clock will be automatically adjusted by the embedded DSP in order to follow the incoming bitstream rate and to avoid input buffer underrun/overflow. A special configuration file must be used to enable this operational mode: the file must be downloaded via I<sup>2</sup>C link after device power-on. Please contact your local ST branch to have more information about.

Figure 6. DATA\_REQ control line

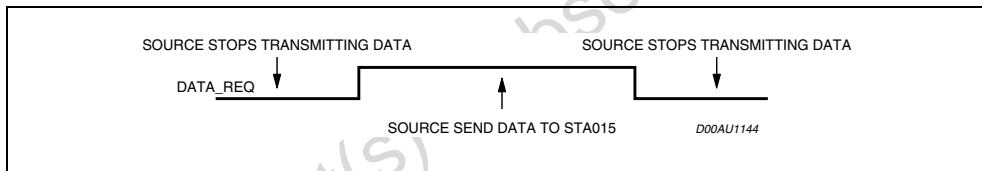

**2.4 STA015 Decoding States**

There are three different decoder states: **Idle**, **Init**, and **Decode**. Commands to change the decoding states are described in the STA015 I<sup>2</sup>C registers description.

**Idle Mode**

In this mode (entered after a S/W or H/W reset) the decoder is waiting for the RUN command. This mode should be used to initialize the configuration registers of the device. The DAC connected to STA015 can be initialized during this mode (set MUTE to 1).

MUTE to 1).

PLAY	MUTE	Clock State	PCM Output
X	0	Not Running	0
X	1	Running	0

**Init Mode**

"PLAY" and "MUTE" changes are ignored in this mode. The internal state of the decoder will be updated only when the decoder changes from the state "init" to the state "decode". The "init" phase ends when the first decoded samples are at the output stage of the device.

**Decode Mode**

This mode is completely described by the following table:

PLAY	MUTE	Clock State	PCM Output	Decoding
0	0	Not Running	0	No
0	1	Running	0	No
1	0	Running	Decoded Samples	Yes
1	1	Running	0	Yes

**Figure 7. MPEG Decoder Interface**

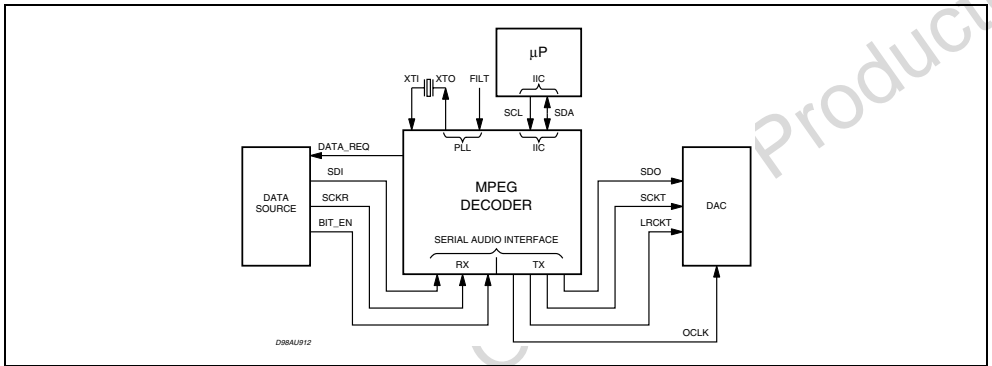

**Figure 8. Serial Input Interface Clocks**

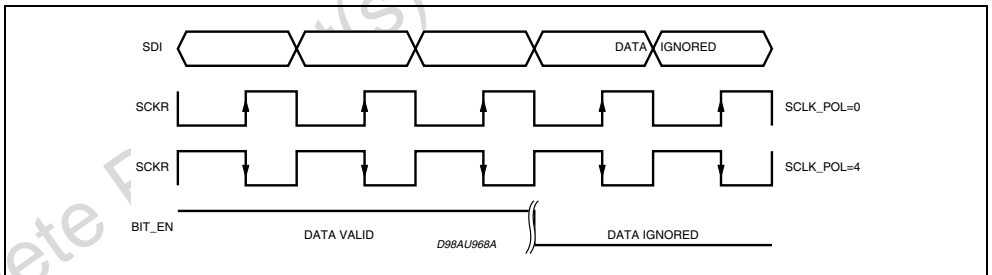

**3.0 INTERFACE DESCRIPTION**

**3.1 Serial Input Interface**

STA015 receives the input data (MSB first) through the Serial Input Interface (Fig.7). It is a serial communication interface connected to the SDI (Serial Data Input) and SCKR (Receiver Serial Clock).

The interface can be configured to receive data sampled on both rising and falling edge of the SCKR clock. The BIT\_EN pin, when set to low, forces the bitstream input interface to ignore the incoming data. For

proper operation BIT\_EN line should be toggled only when SCKR is stable low (for both SCLK\_POL configuration). The possible configurations are described in Fig. 8.

### 3.2 GPSO Output Interface

In order to retrieve ADPCM encoded data a General Purpose Serial Output interface is available (in TQFP44 and LFBGA64 packages only). The maximum frequency for GPSO\_SCKR clock is the DSP system clock frequency divided by 3 (i.e. 8.192 MHz @ 24.58MHz). The interface is based on a simple and configurable 3-lines protocol, as described by figure 10.

### 3.3 PCM Output Interface

The decoded audio data are output in serial PCM format. The interface consists of the following signals:

- SDO            PCM Serial Data Output
- SCKT            PCM Serial Clock Output
- LRCLK          Left/Right Channel Selection Clock

The output samples precision is selectable from 16 to 24 bits/word, by setting the output precision with PCMCONF (16, 18, 20 and 24 bits mode) register. Data can be output either with the most significant bit first (MS) or least significant bit first (LS), selected by writing into a flag of the PCMCONF register.

Figure 9 gives a description of the several STA015 PCM Output Formats. The sample rates set decoded by STA015 is described in Table 1.

To enable the GPSO interface bit GEN of GPSO\_ENABLE register must be set. Using the GPSO\_CONF register the protocol can be configured in order to provide outcoming data on rising/ falling edge of GPSO\_SCKR input clock; the GPSO\_REQ request signal polarity (usually connected to an MCU interrupt line) can be configured as well.

Figure 9. PCM Output Formats

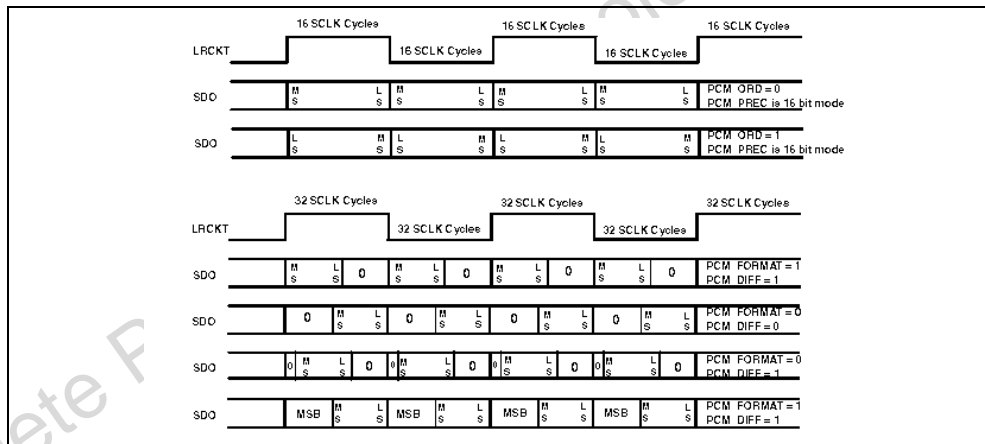

Table 1. MPEG Sampling Rates (KHz)

MPEG 1	MPEG 2	MPEG 2.5
48	24	12
44.1	22.05	11.025
32	16	8

### 3.4 ADC Interface

Beside the serial input interface based on SDI and SCKR lines a 3 wire flexible and user configurable input interface is also available, suitable to interface with most A/D converters. To configure this interface 4 specific I<sup>2</sup>C registers are available (ADC\_ENABLE, ADC\_CONF, ADC\_WLEN and ADC\_WPOS). Refer to registers description for more details.

### 3.5 General Purpose I/O Interface

A new general purpose I/O interface has been added to this device (TQFP44 and LFBGA64 only). Actually only the strobe line is used in ADPCM encoding mode to provide an interrupt; other pins are reserved for future use. The related configuration register is GPIO\_CONF. See the following summary for related pin usage:

Name	Description	Dir
I/ODATA [0] ..... I/ODATA [7]	GPIO data line	I/O ..... I/O
GPIO_STROBE	GPIO strobe line	I/O

### 4.0 ADPCM ENCODING: OVERVIEW

According to the previously described interfaces there are 4 ways to manage ADPCM data stream while encoding. Input interface can be either the serial receiver block (SDI + SCKR + DATA\_REQ lines) or the ADC specific interface.

Output interfaces can be either the I2C bus (with or without interrupt line) or the GPSO high-speed serial interface (GPSO\_REQ + GPSO\_DATA + GPSO\_SCKR lines). This result in the following 4 methods to handle encoding flow:

INPUT (data to encode)	Output (encoded data)	Available on package
ADC I/F (SDI_ADC + LRCK_ADC + SCK_ADC)	GPSO I/F (GPSO_REQ + GPSO_DATA + GPSO_SCKR)	TQFP44/LFBGA64
ADC I/F (SDI_ADC + LRCK_ADC + SCK_ADC)	I <sup>2</sup> C + Interrupt (SCL + SDA + DATA_REQ)	SO28/TQFP44 LFBGA64
SERIAL I/F (SCKR + SDI + DATA_REQ)	GPSO I/F (GPSO_REQ + GPSO_DATA + GPSO_SCKR)	TQFP44/LFBGA64
SERIAL I/F (SCKR + SDI + DATA_REQ) (*)	I <sup>2</sup> C (polling) (SCL + SDA)	SO28/TQFP44 LFBGA64

(\*) STA013 Compatible mode

Figure 10.

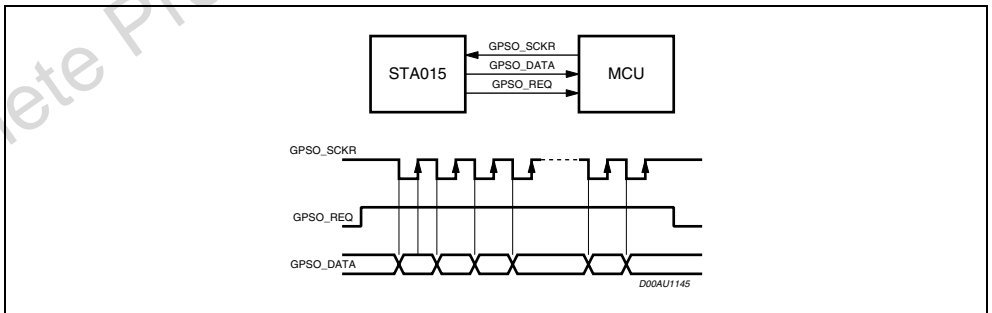
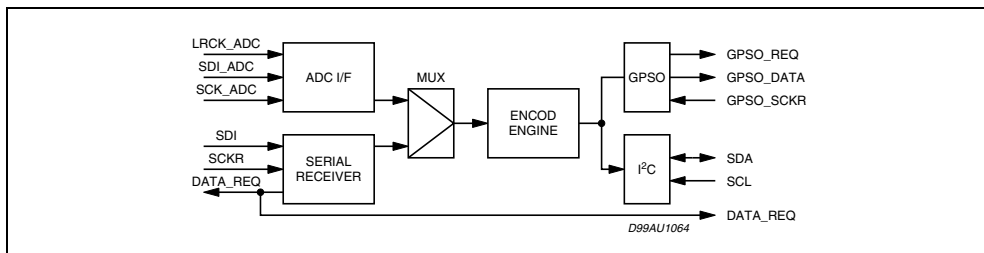

Figure 11.



The following 4 figures (fig. 12, 13, 14, 15) show the available connection diagrams as far as ADPCM encoding function. As shown in the figures some configuration is not available in SO28 package.

Figure 12. Input from BITSTREAM, Output from I²C

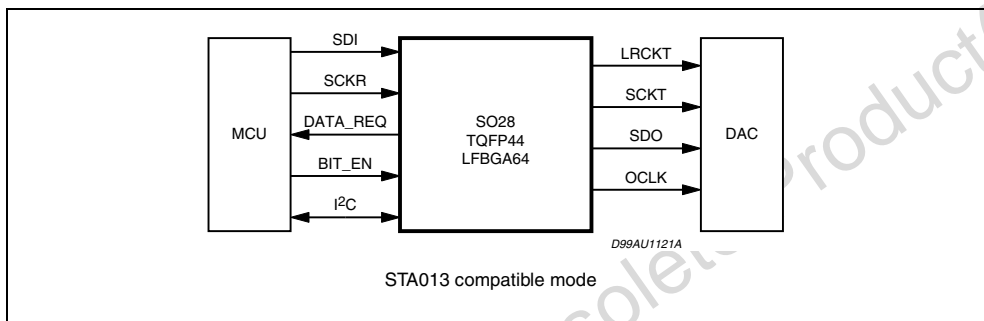

Figure 13. Input from ADC, Output from I²C + IRQ

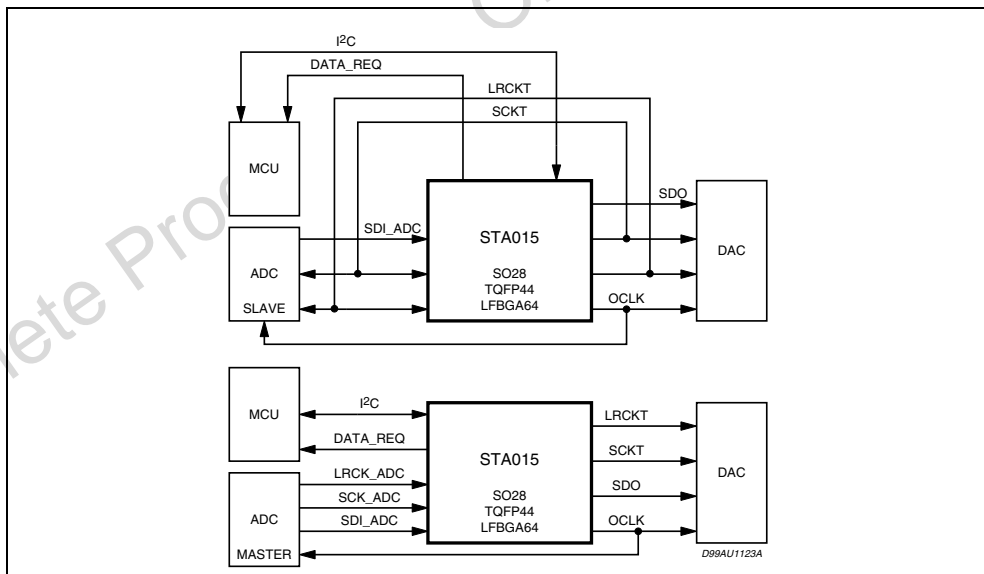

Figure 14. Input from BITSTREAM, Output from GPSO

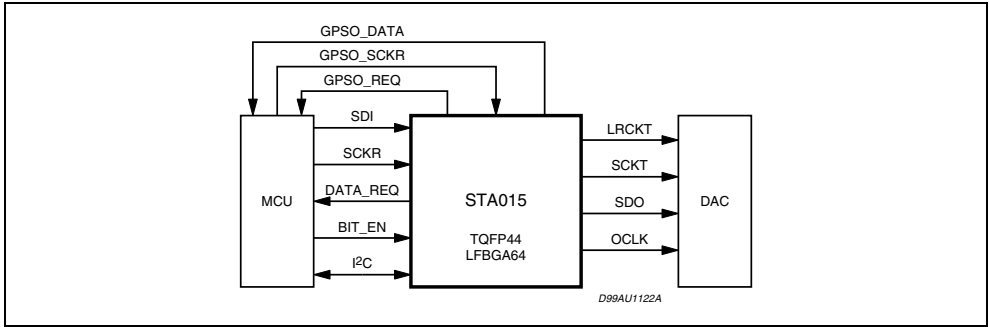
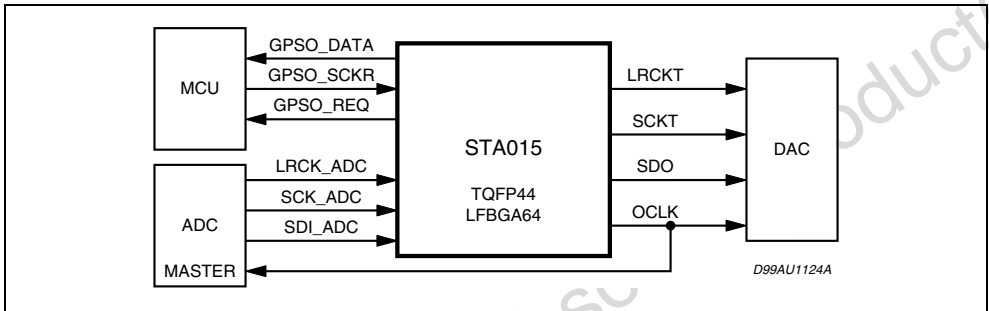

Figure 15. Input from ADC, Output from GPSO



**5.0 I<sup>2</sup>C BUS SPECIFICATION**

The STA015 supports the I<sup>2</sup>C protocol. This protocol defines any device that sends data on to the bus as a transmitter and any device that reads the data as a receiver. The device that controls the data transfer is known as the master and the others as the slave. The master always starts the transfer and provides the serial clock for synchronisation. The STA015 is always a slave device in all its communications.

**5.1 COMMUNICATION PROTOCOL**

**3.1.0 - Data transition or change**

Data changes on the SDA line must only occur when the SCL clock is low. SDA transition while the clock is high are used to identify START or STOP condition.

**5.1.1 Start condition**

START is identified by a high to low transition of the data bus SDA signal while the clock signal SCL is stable in the high state. A START condition must precede any command for data transfer.

**5.1.2 Stop condition**

STOP is identified by low to high transition of the data bus SDA signal while the clock signal SCL is stable in the high state. A STOP condition terminates communications between STA015 and the bus master.

**5.1.3 Acknowledge bit**

An acknowledge bit is used to indicate a successful data transfer. The bus transmitter, either master or slave, releases the SDA bus after sending 8 bit of data. During the 9th clock pulse the receiver pulls the SDA bus low to acknowledge the receipt of 8 bits of data.

### 5.1.4 Data input

During the data input the STA015 samples the SDA signal on the rising edge of the clock SCL. For correct device operation the SDA signal has to be stable during the rising edge of the clock and the data can change only when the SCL line is low.

## 5.2 DEVICE ADDRESSING

To start communication between the master and the STA015, the master must initiate with a start condition. Following this, the master sends onto the SDA line 8 bits (MSB first) corresponding to the device select address and read or write mode. The 7 most significant bits are the device address identifier, corresponding to the I<sup>2</sup>C bus definition. For the STA015 these are fixed as 1000011.

The 8th bit (LSB) is the read or write operation RW, this bit is set to 1 in read mode and 0 for write mode. After a START condition the STA015 identifies on the bus the device address and, if a match is found, it acknowledges the identification on SDA bus during the 9th bit time. The following byte after the device identification byte is the internal space address.

## 5.3 WRITE OPERATION (see fig. 16)

Following a START condition the master sends a device select code with the RW bit set to 0. The STA015 acknowledges this and waits for the byte of internal address.

After receiving the internal bytes address the STA015 again responds with an acknowledge.

### 5.3.1 Byte write

In the byte write mode the master sends one data byte, this is acknowledged by STA015. The master then terminates the transfer by generating a STOP condition.

### 5.3.2 Multibyte write

The multibyte write mode can start from any internal address. The transfer is terminated by the master generating a STOP condition.

Figure 16. Write Mode Sequence

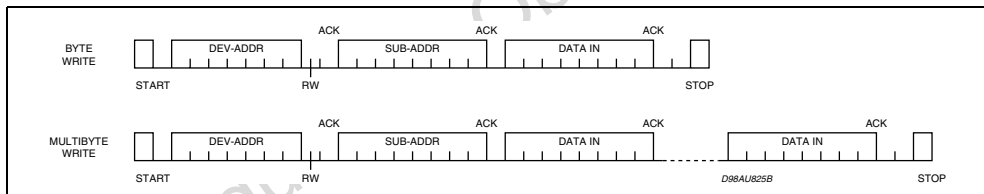
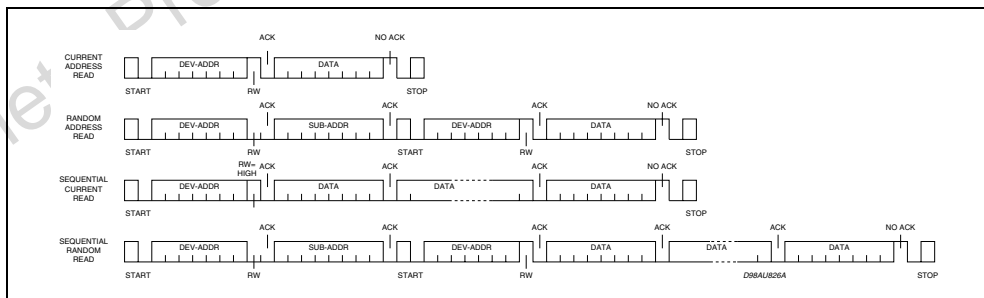

Figure 17. Read Mode Sequence





**5.4 READ OPERATION (see Fig. 17)**

**5.4.1 Current byte address read**

The STA015 has an internal byte address counter. Each time a byte is written or read, this counter is incremented. For the current byte address read mode, following a START condition the master sends the device address with the RW bit set to 1.

The STA015 acknowledges this and outputs the byte addressed by the internal byte address counter. The master does not acknowledge the received byte, but terminates the transfer with a STOP condition.

**5.4.2 Sequential address read**

This mode can be initiated with either a current address read or a random address read. However in this case the master does acknowledge the data byte output and the STA015 continues to output the next byte in sequence. To terminate the streams of bytes the master does not acknowledge the last received byte, but terminates the transfer with a STOP condition. The output data stream is from consecutive byte addresses, with the internal byte address counter automatically incremented after one byte output.

**6.0 I<sup>2</sup>C REGISTERS**

The following table gives a description of the MPEG Source Decoder (STA015) register list.

The first column (HEX\_COD) is the hexadecimal code for the sub-address.

The second column (DEC\_COD) is the decimal code.

The third column (DESCRIPTION) is the description of the information contained in the register.

The fourth column (RESET) indicate the reset value if any. When no reset value is specified, the default is "undefined".

The fifth column (R/W) is the flag to distinguish register "read only" and "read and write", and the useful size of the register itself. Each register is 8 bit wide. The master shall operate reading or writing on 8 bits only.

**I<sup>2</sup>C REGISTERS**

HEX_COD	DEC_COD	DESCRIPTION	RESET	R/W
\$00	0	VERSION		R (8)
\$01	1	IDENT	0xAC	R (8)
\$05	5	PLLCTL [7:0]	0xA1	R/W (8)
\$06	6	PLLCTL [20:16] (MF[4:0]=M)	0x0C	R/W (8)
\$07	7	PLLCTL [15:12] (IDF[3:0]=N)	0x00	R/W (8)
\$0C	12	REQ_POL	0x01	R/W (8)
\$0D	13	SCLK_POL	0x04	R/W (8)
\$0F	15	ERROR_CODE	0x00	R (8)
\$10	16	SOFT_RESET	0x00	W (8)
\$13	19	PLAY	0x01	R/W(8)
\$14	20	MUTE	0x00	R/W(8)
\$16	22	CMD_INTERRUPT	0x00	R/W(8)
\$18	24	DATA_REQ_ENABLE	0x00	R/W(8)
\$40 - \$51	64 - 81	ADPCM_DATA_1 to ADPCM_DATA_18	0x00	R (8)
\$40	64	SYNCSTATUS	0x00	R (8)
\$41	65	ANCCOUNT_L	0x00	R (8)
\$42	66	ANCCOUNT_H	0x00	R (8)
\$43	67	HEAD_H[23:16]	0x00	R(8)
\$44	68	HEAD_M[15:8]	0x00	R(8)

I<sup>2</sup>C REGISTERS

\$45	69	HEAD_L[7:0]	0x00	R(8)
\$46	70	DLA	0x00	R/W (8)
\$47	71	DLB	0xFF	R/W (8)
\$48	72	DRA	0x00	R/W (8)
\$49	73	DRB	0xFF	R/W (8)
\$4D	77	CHIP_MODE	0x00	R/W (2)
\$4E	78	CRCR	0x00	R/W (1)
\$50	80	MFSDF_441	0x00	R/W (8)
\$51	81	PLLFRAC_441_L	0x00	R/W (8)
\$52	82	ADPCM_DATA_READY	0x00	R/W (1)
\$52	82	PLLFRAC_441_H	0x00	R/W (8)
\$53	83	ADPCM_SAMPLE_FREQ	0x00	R/W (4)
\$54	84	PCM DIVIDER	0x03	R/W (8)
\$55	85	PCMCONF	0x21	R/W (8)
\$56	86	PCM CROSS	0x00	R/W (8)
\$61	97	MFSDF (X)	0x07	R/W (8)
\$63	99	DAC_CLK_MODE	0x00	R/W (8)
\$64	100	PLLFRAC_L	0x46	R/W (8)
\$65	101	PLLFRAC_H	0x5B	R/W (8)
\$67	103	FRAME_CNT_L	0x00	R (8)
\$68	104	FRAME_CNT_M	0x00	R (8)
\$69	105	FRAME_CNT_H	0x00	R (8)
\$6A	106	AVERAGE_BITRATE	0x00	R (8)
\$71	113	SOFTVERSION		R (8)
\$72	114	RUN	0x00	R/W (8)
\$77	119	TREBLE_FREQUENCY_LOW	0x00	R/W (8)
\$78	120	TREBLE_FREQUENCY_HIGH	0x00	R/W (8)
\$79	121	BASS_FREQUENCY_LOW	0x00	R/W (8)
\$7A	122	BASS_FREQUENCY_HIGH	0x00	R/W (8)
\$7B	123	TREBLE_ENHANCE	0x00	R/W (8)
\$7C	124	BASS_ENHANCE	0x00	R/W (8)
\$7D	125	TONE_ATTEN	0x00	R/W (8)
\$7E - B5	126 - 181	ANC_DATA_1 to ANC_DATA_56	0x00	R (8)
\$B6	182	ISR	0x00	R/W (1)
\$B8	184	ADPCM_CONFIG	0x00	R/W (2)
\$B9	185	GPSO_ENABLE	0x00	R/W (1)
\$BA	186	GPSO_CONF	0x00	R/W (2)
\$BB	187	ADC_ENABLE	0x00	R/W (1)
\$BC	188	ADC_CONF	0x00	R/W (5)
\$BD	189	ADPCM_FRAME_SIZE	0x00	R/W (8)
\$BE	190	ADPCM_INT_CFG	0x00	R/W (8)
\$BF	191	GPIO_CONF	0x00	R/W (2)
\$C0	192	ADC_WLEN	0x0F	R/W (5)
\$C1	193	ADC_WPOS	0x00	R/W (5)
\$C2	194	ADPCM_SKIP_FRAME	0x00	R/W (8)

Notes: 1. The HEX\_COD is the hexadecimal address that the microcontroller has to generate to access the information.  
 2. RESERVED: register used for production test only, or for future use.

**6.1 STA015 REGISTERS DESCRIPTION**

The STA015 device includes 128 I<sup>2</sup>C registers. In this document, only the user-oriented registers are described. The undocumented registers are reserved. These registers must never be accessed (in Read or in Write mode). The Read-Only registers must never be written.

The following table describes the meaning of the abbreviations used in the I<sup>2</sup>C registers description:

Symbol	Comment
NA	Not Applicable
UND	Undefined
NC	No Charge
RO	Read Only
WO	Write Only
R/W	Read and Write
R/WS	Read, Write in specific mode

**VERSION**

**Address: 0x00 (00)**

Type: RO

MSB							LSB
b7	b6	b5	b4	b3	b2	b1	b0
V8	V7	V6	V5	V4	V3	V2	V1

The VERSION register is read-only and it is used to identify the IC on the application board.

**IDENT**

**Address: 0x01**

Type: RO

Software Reset: 0xAC

Hardware Reset: 0xAC

MSB							LSB
b7	b6	b5	b4	b3	b2	b1	b0
1	0	1	0	1	1	0	0

IDENT is a read-only register and is used to identify the IC on an application board. IDENT always has the value "0xAC"

**PLLCTL**

**Address: 0x05**

Type: R/W

Software Reset: 0x21

Hardware Reset: 0x21

MSB							LSB
b7	b6	b5	b4	b3	b2	b1	b0
XTO_BUF	XTODIS	OCLKEN	SYS2OCLK	PPLDIS	XTI2DSPCLK	XTI2OCLK	UPD_FRAC

*UPD\_FRAC*: when is set to 1, update FRAC in the switching circuit. It is set to 1 after autoboot.

*XTI2OCLK*: when is set to 1, use the XTI as input of the divider X instead of VCO output. It is set to 0 on HW reset.

*XTI2DSPCLK*: when is to 1, set use the XTI as input of the divider S instead of VCO output. It is set to 0 on HW reset.

*PLLDIS*: when set to 1, the VCO output is disabled. It is set to 0 on HW reset.

*SYS2OCLK*: when is set to 1, the OCLK frequency is equal to the system frequency. It is useful for testing. It is set to 0 on HW reset.

*OCLKEN*: when is set to 1, the OCLK pad is enable as output pad. It is set to 1 on HW reset.

*XTODIS*: when is set to 1, the XTO pad is disable. It is set to 0 on HW reset.

*XTO\_BUF*: when this bit is set, the pin nr. 28 (OUT\_CLOCK/DATA\_REQ) is enabled. It is set to 0 after autoboot.

**PLLCTL (M)**

**Address: 0x06 (06)**

Type: R/W

Software Reset: 0x0C

Hardware Reset: 0x0C

**PLLCTL (N)**

**Address: 0x07 (07)**

Type: R/W

Software Reset: 0x00

Hardware Reset: 0x00

The M and N registers are used to configure the STA015 PLL by DSP embedded software.

M and N registers are R/W type but they are completely controlled, on STA015, by DSP software.

**REQ\_POL**

**Address: 0x0C (12)**

Type: R/W

Software Reset: 0x01

Hardware Reset: 0x00

The REQ\_POL registers is used to program the polarity of the DATA\_REQ line.

MSB							LSB
b7	b6	b5	b4	b3	b2	b1	b0
0	0	0	0	0	0	0	1

Default polarity (the source sends data when the DATA\_REQ line is high)

MSB							LSB
b7	b6	b5	b4	b3	b2	b1	b0
0	0	0	0	0	1	0	1

Inverted polarity (the source sends data when the ATA\_REQ line is low)

**SCKL\_POL**

**Address: 0x0D (13)**

Type: R/W

Software Reset: 0x04

Hardware Reset: 0x04

MSB					LSB			
b7	b6	b5	b4	b3	b2	b1	b0	
X	X	X	X	X	0	0	0	(1)
					1	0	0	(2)

X = don't care

SCKL\_POL is used to select the working polarity of the Input Serial Clock (SCKR).

- (1) If SCKL\_POL is set to 0x00, the data (SDI) are sent with the falling edge of SCKR and sampled on the rising edge.
- (2) If SCKL\_POL is set to 0x04, the data (SDI) are sent with the rising edge of SCKR and sampled on the falling edge.

**ERROR\_CODE**

**Address: 0x0F (15)**

Type: RO

Software Reset: 0x00

Hardware Reset: 0x00

MSB					LSB		
b7	b6	b5	b4	b3	b2	b1	b0
X	X	EC5	EC4	EC3	EC2	EC1	EC0

X = don't care

ERROR\_CODE register contains the last error occurred if any. The codes can be as follows:

CODE	Description
0x00	No error since the last SW or HW Reset
0x01	CRC Failure
0x02	DATA not available
0x04	Ancillary data not read
0x10	Audio synch word not found
0x2X	MPEG Header error
0x3X	MPEG Decoding errors

**SOFT\_RESET****Address: 0x10 (16)**

Type: WO

Software Reset: 0x00

Hardware Reset: 0x00

MSB							LSB
b7	b6	b5	b4	b3	b2	b1	b0
X	X	X	X	X	X	X	0
							1

X = don't care; 0 = normal operation; 1 = reset

When this register is written, a soft reset occurs. The STA015 core command register and the interrupt register are cleared. The decoder goes in to idle mode.

**PLAY****Address: 0x13 (19)**

Type: R/W

Software Reset: 0x01

Hardware Reset: 0x01

MSB							LSB
b7	b6	b5	b4	b3	b2	b1	b0
X	X	X	X	X	X	X	0
							1

X = don't care; 0 = normal operation; 1 = play

The PLAY command is handled according to the state of the decoder, as described in section 2.5. PLAY only becomes active when the decoder is in DECODE mode.

**MUTE****Address: 0x14**

Type: R/W

Software Reset: 0x00

Hardware Reset: 0x00

MSB							LSB
b7	b6	b5	b4	b3	b2	b1	b0
X	X	X	X	X	X	X	0
							1

X = don't care; 0 = normal operation; 1 = mute The MUTE command is handled according to the state of the decoder, as described in section 2.5. MUTE sets the clock running.

**CMD\_INTERRUPT**

**Address: 0x16 (22)**

Type: R/W

Software Reset: 0x00

Hardware Reset: 0x00

MSB							LSB
b7	b6	b5	b4	b3	b2	b1	b0
X	X	X	X	X	X	X	0
							1

X = don't care;

0 = normal operation;

1 = write into I<sup>2</sup>C/Ancillary Data

The INTERRUPT is used to give STA015 the command to write into the I<sup>2</sup>C/Ancillary Data Buffer (Registers: 0x7E ... 0xB5). Every time the Master has to extract the new buffer content it writes into this register, setting it to a non-zero value.

**DATA\_REQ\_ENABLE**

**Address: 0x18 (24)**

Type: R/W

Software Reset: 0x00

Hardware Reset: 0x00

MSB							LSB		Description
b7	b6	b5	b4	b3	b2	b1	b0		
X	X	X	X	X	0	X	X	buffered output clock	
X	X	X	X	X	1	X	X	request signal	

The DATA\_REQ\_ENABLE register is used to configure Pin n. 28 working as buffered output clock or data request signal, used for multimedia mode.

The buffered Output Clock has the same frequency than the input clock (XTI)

**SYNCSTATUS**

**Address: 0x40 (64)**

Type: RO

Software Reset: 0x00

Hardware Reset: 0x00

MSB							LSB		Description
b7	b6	b5	b4	b3	b2	b1	b0		
X	X	X	X	X	X	SS1	SS0		
							0	0	Research of sync word
							0	1	Wait for Confirmation
							1	0	Synchronised

**ADPCM\_DATA BUFFER****Address: 0x40 - 0x51 (64 - 81)**

Type: R/W

Software Reset: 0x00

Hardware Reset: 0x00

MSB				LSB			
b7	b6	b5	b4	b3	b2	b1	b0
ENCODED DATA N to N+18							

**ANCCOUNT\_L****Address: 0x41 (65)**

Type: RO

Software Reset: 0x00

Hardware Reset: 0x00

MSB				LSB			
b7	b6	b5	b4	b3	b2	b1	b0
AC7	AC6	AC5	AC4	AC3	AC2	AC1	AC0

**ANCCOUNT\_H****Address: 0x42 (66)**

Type: RO

Software Reset: 0x00

Hardware Reset: 0x00

ANCCOUNT\_H

MSB				LSB			
b7	b6	b5	b4	b3	b2	b1	b0
AC15	AC14	AC13	AC12	AC11	AC10	AC9	AC8

ANCCOUNT registers are logically concatenated and indicate the number of Ancillary Data bits available at every correctly decoded MPEG frame.

**HEAD\_H[23:16]**

MSB				LSB			
b7	b6	b5	b4	b3	b2	b1	b0
X	X	X	H20	H19	H18	H17	H16

x = don't care



**HEAD\_M[15:8]**

MSB				LSB			
b7	b6	b5	b4	b3	b2	b1	b0
H15	H14	H13	H12	H11	H10	H9	H8

**HEAD\_L[7:0]**

MSB				LSB			
b7	b6	b5	b4	b3	b2	b1	b0
H7	H6	H5	H4	H3	H2	H1	H0

**Address: 0x43, 0x44, 0x45 (67, 68, 69)**

Type: RO

Software Reset: 0x00

Hardware Reset: 0x00

Head[1:0] emphasis

Head[2] original/copy

Head[3] copyrightHead

[5:4] mode extension

Head[7:6] mode

Head[8] private bit

Head[9] padding bit

Head[11:10] sampling frequency index

Head[15:12] bitrate index

Head[16] protection bit

Head[18:17] layer

Head[19] ID

Head[20] ID\_ex

The HEAD registers can be viewed as logically concatenated to store the MPEG Layer III Header content. The set of three registers is updated every time the synchronisation to the new MPEG frame is achieved. The meaning of the flags are shown in the following tables:

**MPEG IDs**

IDex	ID	
0	0	MPEG 2.5
0	1	reserved
1	0	MPEG 2
1	1	MPEG 1

**Layer**

in Layer III these two flags must be set always to "01".

**Protection\_bit**

It equals "1" if no redundancy has been added and "0" if redundancy has been added.

**Bitrate\_index**

indicates the bitrate (Kbit/sec) depending on the MPEG ID.

bitrate index	ID = 1	ID = 0
'0000'	free	free
'0001'	32	8
'0010'	40	16
'0011'	48	24
'0100'	56	32
'0101'	64	40
'0110'	80	48
'0111'	96	56
'1000'	112	64
'1001'	128	80
'1010'	160	96
'1011'	192	112
'1100'	224	128
'1101'	256	144
'1110'	320	160
'1111'	forbidden	forbidden

**Sampling Frequency**

indicates the sampling frequency of the encoded audio signal (KHz) depending on the MPEG ID

Sampling Frequency	MPEG1	MPEG2	MPEG2.5
'00'	44.1	22.05	11.03
'01'	48	24	12
'10'	32	16	8
'11'	reserved	reserved	reserved

**Padding bit**

if this bit equals '1', the frame contains an additional slot to adjust the mean bitrate to the sampling frequency, otherwise this bit is set to '0'.

**Private bit**

Bit for private use. This bit will not be used in the future by ISO/IEC.

**Mode**

Indicates the mode according to the following table. The joint stereo mode is intensity\_stereo and/or ms\_stereo.

mode	mode specified
'00'	stereo
'01'	joint stereo (intensity_stereo and/or ms_stereo)
'10'	dual_channel
'11'	single_channel (mono)